

MATENG



Finishing Mower

OPERATOR'S MANUAL

ME-RC60/72

ME-RC60H/72H

ME-RC60-DISC/72-DISC

ME-RC60H-DISC/72H-DISC

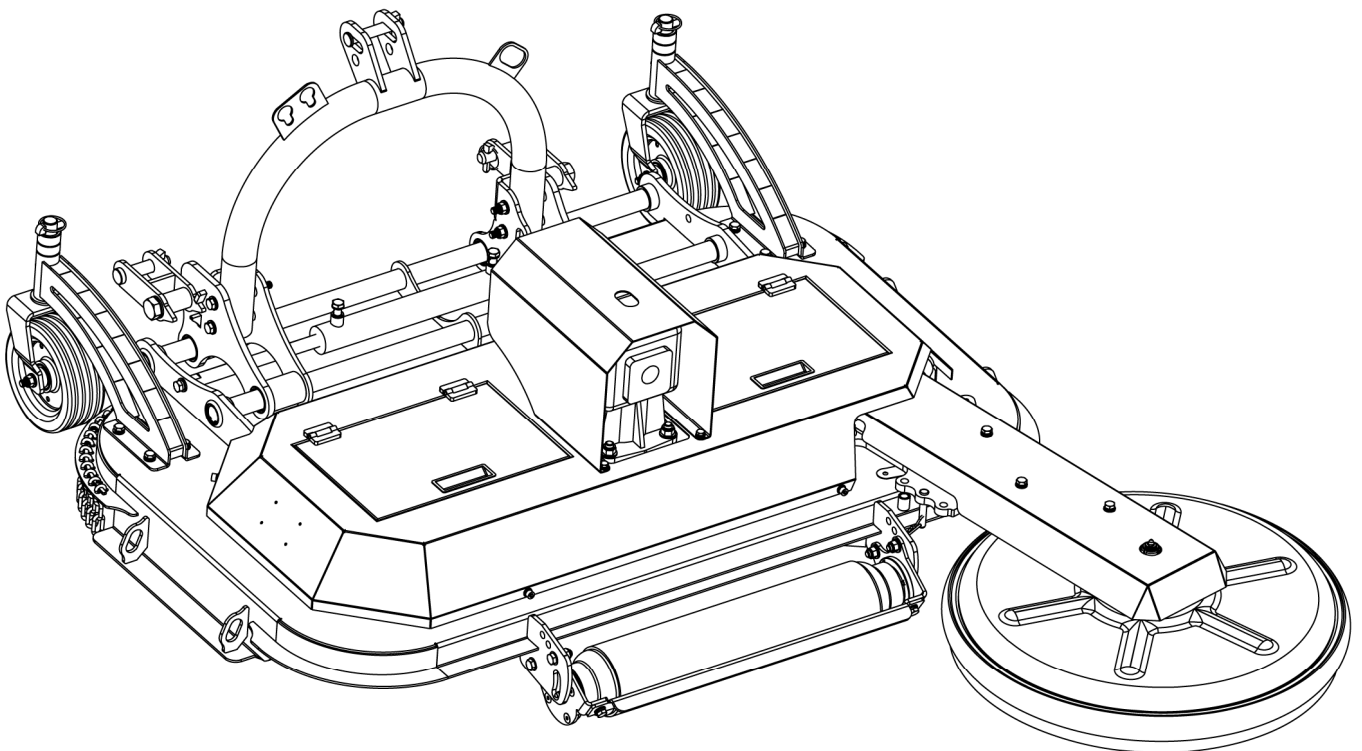

Please carefully read this manual and follow all the instructions. Failure to comply with the warnings and precautions may result in serious injury or death.

V2.1 3250200978

Content

CONTENT	1
SAFETY PRECAUTIONS	3
Safety First	3
Safety Alert Symbol	4
Safety for Children.....	4
Operation Safety	5
Tractor Shutdown Safety	5
Use A Safety Chain.....	5
Transport Safely	6
Avoid Crystalline Silica (Quartz) Dust	6
Avoid Contact Blades	7
Maintenance Safety	7
Preparation before Maintenance.....	8
Personal Protective Equipment.....	8
Keep Riders off Machinery.....	9
Safety Lights and Devices	9
Seat Belt and ROPS	9
Hydraulic System Safety	9
Handle Chemicals Properly	10
Tire Maintenance Safety	10
Storage and Disposal Safety	11
Storage Safety	11
Disposal Safety.....	11
Safety Labels.....	11
Labels Location.....	12
PRODUCT INTRODUCTION	14
Technical Data.....	14
Implement Identification.....	16
ASSEMBLY & SET-UP	19

Tractor Shutdown	20
Tractor Hook-up	21
Driveline Installation.....	22
Driveline Length Check.....	24
Maximum Extended Position	24
Customize Driveline.....	25
Driveline Interference Check	26
OPERATION	27
General Operating Instructions	27
Checklist before Operation	28
Levelling the Mower.....	28
Adjusting Wheel Height.....	29
Starting the Machine.....	30
Inspection before Starting.....	30
Operation the Machine	30
SERVICE AND MAINTENANCE	31
General Service.....	31
Gearbox Maintenance.....	31
PTO Shaft Maintenance	31
Lubrication Parts	32
Tightening Torque.....	34
Replacing the Blade.....	35
STORAGE AND TRANSPORT	36
Storage	36
Transport	36
TROUBLESHOOTING	37
EXPLODED VIEW AND PARTS LIST	39
WARRANTY.....	69

SAFETY PRECAUTIONS

Listed below are common practices that may or may not be applicable to the products described in this manual.

Safety First

Careful operation is your best assurance against an accident.

Please be fully aware that you are responsible for the safe operation and maintenance of your implement. You must ensure that you and anyone else who is going to operate, maintain or work around the implement is familiar with the operating and maintenance procedures and related safe information contained in this manual. This manual is prepared to guide you through all essential operations related to this implement and alert you to all good safety practices that should be strictly followed.

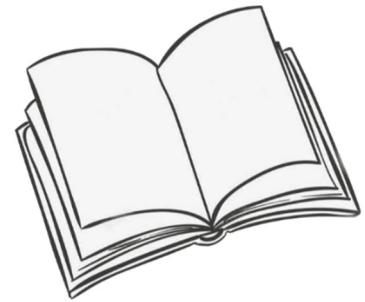

Please constantly bear in mind that good safety practices not only protect you but also the people around you. Incorporate these practices an inseparable part into your safety program. Make sure that who operates this equipment is familiar with the recommended operating and maintenance procedures and follows all the safety precautions. Most accidents can be prevented. Do not risk injury of death by ignoring good safety practices.

- Thoroughly read and understand the “**Safety Labels**” section. Read all instructions noted on them.
- Do not operate the equipment while under the influence of drugs or alcohol, as they impair your ability to safely and properly operate the equipment.
- The operator should be familiar with all functions of the tractor and attached implement, and be able to handle emergencies quickly.
- Make sure all guards and shields appropriate for the operation are in place and secured before operating the implement.
- Keep all bystanders away from equipment and work area. Start tractor from the driver’s seat with hydraulic controls in neutral.
- Operate tractor and controls from the driver’s seat only.
- Never dismount from a moving tractor or leave tractor unattended with engine running.
- Do not allow anyone to stand between the implement and tractor while backing up to the implement.
- Keep hands, feet, and clothing away from power-driven parts.

- While transporting and operating equipment, watch out for objects overhead and along the sides such as fences, trees, buildings, wires, etc.
- Do not turn tractor so tight as to cause hitched implement to ride up on the tractor's rear wheel.
- Store implement in a safe and secure area where children normally do not play. When needed, secure implement against falling with support blocks.

Safety Alert Symbol

The SAFETY ALERT SYMBOL indicates there is a potential hazard to personal safety and extra precaution must be taken. When you see this symbol, be alert and carefully read the message that follows it. Hazard control, and accident prevention are dependent upon the awareness, concern, prudence, and proper training of personnel involved in the operation, transport, maintenance, and storage of equipment.

Be Aware of Signal Words

A signal word designates a degree or level of hazard seriousness. They are:

 **DANGER:** Indicates a hazardous situation that, if not avoided, will result in death or serious injury.

 **WARNING:** Indicates a hazardous situation that, if not avoided, could result in death or serious injury.

 **CAUTION:** Indicates a hazardous situation that, if not avoided, may result in minor or moderate injury.

Be Aware of Special Notices

Special notices are intended to point out important and helpful information that should be followed. They are:

ATTENTION: Indicates that equipment or property damage could result if instructions are not followed.

NOTE: Indicates supplementary explanations that will be helpful when using the equipment.

Safety for Children

Tragedy can occur if the operator is not alert to the presence of children, Children generally are attracted to implements and their work.

- Never assume children will remain where you last saw them.
- Keep children out of the work area and under the watchful eye of a responsible adult.

- Be alert and shut the implement and tractor down if children enter the work area.
- Never carry children on the tractor or implement. There is not a safe place for them to ride. They may fall off and be run over or interfere with the control of the power machine.
- Never allow children to operate the power machine, even under adult supervision.
- Never allow children to play on the power machine or implement.

Operation Safety

Use extra caution when backing up. Before the tractor starts to move, look down and behind to make sure the area is safety and clear.

Tractor Shutdown Safety

If engaged, disengage power take-off.

Park on solid, level ground and lower implement to ground or onto support blocks.

- Put tractor in park or set park brake.
- Turn off engine and remove ignition key to prevent unauthorized starting.
- Relieve all hydraulic pressure to auxiliary hydraulic lines.
- Wait for all components to stop before leaving operator's seat.
- Use steps, grab-handles and anti-slip surfaces when stepping on or off the tractor.
- If engaged, disengage power take-off.
- Park on solid, level ground and lower implement to ground or onto support blocks.
- Put tractor in park or set park brake.
- Turn off engine and remove ignition key to prevent unauthorized starting.
- Relieve all hydraulic pressure to auxiliary hydraulic lines.
- Wait for all components to stop before leaving operator's seat.
- Use steps, grab-handles and anti-slip surfaces when stepping on and off the tractor.

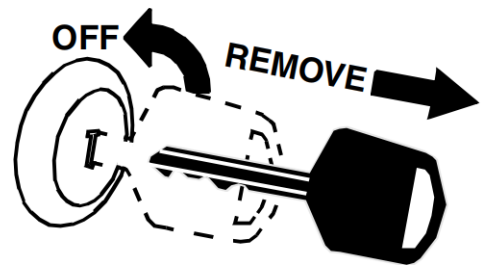

Use a Safety Chain

A safety chain will help control drawn machinery should it separate from the tractor drawbar.

Use a chain with the strength rating equal to or greater than the gross weight of the towed implement.

- Attach the chain to the tractor drawbar support or other specified anchor location. Allow only



enough slack in the chain to permit turning.

- Always hitch the implement to the machine towing it. Do not use the safety chain to tow the implement.

Transport Safely

- Comply with federal, state, and local laws.
- Avoid contact with any overhead utility lines or electrically charged conductors.
- Engage park brake when stopped on an incline.
- Maximum transport speed for an implement is 30 km/h. DO NOT EXCEED.
- Never travel at a speed which does not allow adequate control of steering and stopping. Some rough terrains require a slower speed. Sudden braking can cause a towed load to swerve and upset.
- Do not tow an implement that, when fully loaded, weights more than 1.5 times the weight of towing vehicle.

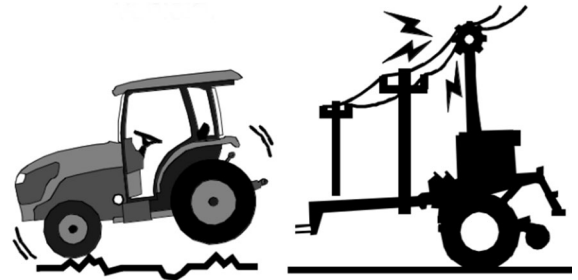

Avoid Crystalline Silica (Quartz) Dust

Because crystalline silica is a basic component of sand and granite, many activities at construction sites produce dust containing crystalline silica. Trenching, sawing, and boring of material containing crystalline silica can produce dust containing crystalline silica particles. This dust can cause serious injury to the lungs (silicosis). There are guidelines which should be followed if crystalline silica (quartz) is present in the dust.

- Be aware of and follow OSHA (or other local, State, or Federal) guidelines for exposure to airborne crystalline silica.
- Know the work operations where exposure to crystalline silica may occur.
- Participate in air monitoring or training programs offered by the employer.
- Be aware of and use optional equipment controls such as water sprays, local exhaust ventilation, and enclosed cabs with positive pressure air conditioning if the machine has such equipment. Otherwise respirators shall be worn.
- Where respirators are required, wear a respirator approved for protection against crystalline silica containing dust. Do not alter respirator in any way. Workers who use tight-fitting respirators cannot have beards/ mustaches which interfere with the respirator seal to the face.
- If possible, change into disposable or washable work clothes at the work site; shower and



change into clean clothing before leaving the work site.

- Do not eat, drink, use tobacco products, or apply cosmetics in areas where there is dust containing crystalline silica.
- Store food, drink, and personal belongings away from the work area.
- Wash hands and face before eating, drinking, smoking, or applying cosmetics after leaving the exposure area.

Avoid Contact Blades

Keep away from rotating blades to avoid death or serious injury from blade contact.

- Stay away and keep hands, feet and body away from rotating blades, drivelines and parts until all moving elements have stopped.
- Do not put hands or feet under mower hood.
- Stop rotating blades disengage PTO and wait for blade to stop rotating before raising mower hood or swings.
- Stop look and listen before approaching the mower to make sure all rotating motion has stopped.
- If a material blockage occurs in the inlet or discharge areas of the mower, shut down tractor engine, disengage the PTO and wait for all rotating motions to stop. Place the tractor in park position, engage the parking brake and remove the key before leaving the operator's seat. Clear the blockage before processing with mowing. Be sure to keep feet and hands clear of the mower blades. If you raise the mower or swing to access the blockage, engage the swing lock up latch and securely block up the mower before placing any parts of the body beneath the mower.

Maintenance Safety

- Good maintenance is your responsibility. Poor maintenance is an invitation to trouble.
- Follow good shop practices.
- Keep service area clean and dry.
- Be sure electrical outlets and tools are properly grounded.
- Use adequate light for the job at hand.
- Make sure there is plenty of ventilation. Never operate the engine of the tractor in a closed area. The exhaust gas may cause healthy problem.
- Before maintenance, shut off the tractor (See [Tractor Shutdown](#)).
- Allow equipment to cool before maintenance operation.

- Never work under the machine unless it is secured by a mechanical stand.
- Use personal protection devices such as safety goggles, hand gloves and hearing protectors, when performing any service or maintenance work. Use heavy gloves when handling blades.
- Only use original parts for service and maintenance.
- A fire extinguisher and first aid kit should be kept readily accessible while performing maintenance on this equipment.
- Periodically tighten all bolts, nuts and screws and check that all pins are properly installed to ensure unit is in a safe condition.
- Do not weld or torch on galvanized metal as it will release toxic fumes.
- Always make sure any material and waste products from the repair and maintenance of the implement are properly collected and disposed.
- Disconnect battery (If the implement has the battery) ground cable (-) before servicing or adjusting electrical systems or before welding on implement.
- Do not grease or oil implement while it is in operation.
- Do not work under any hydraulically supported equipment. It can settle, suddenly leak down, or be lowered accidentally. If it is necessary to work under the equipment, securely support it with stands or suitable blocking beforehand.
- When completing a maintenance or service function, make sure all safety shields and devices are installed before placing machine in service.

Preparation before Maintenance

- Be prepared if a fire starts.
- Keep a first aid kit and fire extinguisher handy.
- Keep emergency numbers for ambulance, hospital and fire department near the working area.

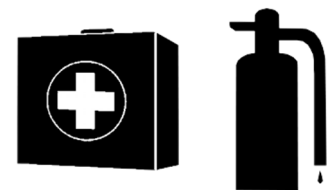

Personal Protective Equipment

- Wear protective clothing and equipment appropriate for the job such as safety shoes, safety glasses, hard hat, dust mask, and ear plugs.
- Clothing should fit snug without fringes and pull strings to avoid entanglement with moving parts.
- Prolonged exposure to loud noise can cause hearing impairment or hearing loss. Wear suitable hearing protection such as earmuffs or earplugs.
- Operating a machine safely requires the operator's full attention. Avoid wearing headphones



while operating equipment.

Keep Riders off Machinery

- Never carry riders on the tractor or implement.
- Riders obstruct operator's view and interfere with the control of the power machine.
- Riders can be struck by objects or thrown from the equipment.
- Never use the tractor or implement to lift or transport riders.



Safety Lights and Devices

- A slow moving power machine can create a hazard when driven on public roads. They are difficult to see, especially at night.
- Flashing warning lights and turn signals are recommended whenever driving on public roads.
- For tractors and other agriculture equipment, a Slow Moving Vehicle (SMV) sign is required when traveling on public roads.

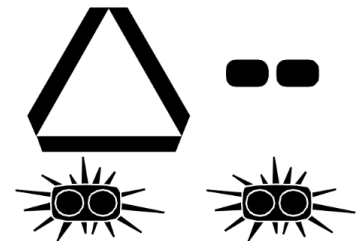

Seat Belt and ROPS

- We recommends the use of a CAB or roll-over-protective structures (ROPS) and seat belt in almost all power machines. Combination of a CAB or ROPS and seat belt will reduce the risk of serious injury or death if the power machine should be upset.
- If ROPS is in the locked-up position, fasten seat belt snugly and securely to help protect against serious injury or death from falling and machine overturn.



Hydraulic System Safety

- Escaping fluid under pressure will penetrate the skin or eyes causing serious injury.
- Relieve all residual pressure before disconnecting hydraulic lines or performing work on the hydraulic system.
- Make sure all hydraulic fluid connections are properly tightened/torqued and all hydraulic hoses and lines are in good condition before applying pressure to the system.
- Use a piece of paper or cardboard, NOT BODY PARTS, to check



for suspected leaks.

- Wear proper hand and eye protection when searching for a high pressure hydraulic leak. Use a piece of wood or cardboard as a backstop instead of hands to isolate and identify a leak.
- DO NOT DELAY. If an accident occurs, seek immediate emergency medical care or gangrene may result.



Handle Chemicals Properly

- Protective clothing should be worn.
- Handle all chemicals with care.
- Follow instructions on container label.
- Agricultural chemicals can be dangerous. Improper use can seriously injure persons, animals, plants, soil, and property.
- Inhaling smoke from any type of chemical fire can be a serious health hazard.
- Store or dispose of unused chemicals as specified by the chemical manufacturer.



Tire Maintenance Safety

- Tire changing can be dangerous and must be performed by trained personnel using the correct tools and equipment.
- Always properly match the wheel size to the properly sized tire.
- Always maintain correct tire pressure. Do not inflate tires above recommended pressures shown in the Operator's Manual.
- When inflating tires, use a clip-on chuck and extension hose long enough to allow you to stand to one side and NOT in front of or over the tire assembly. Use a safety cage if available.
- Securely support the implement when changing a wheel.
- When removing and installing wheels, use wheel handling equipment adequate for the weight involved.
- Make sure wheel bolts have been tightened to the specified torque.



Storage and Disposal Safety

Storage Safety

1. Store the machine in an area away from human activity. Do keep the machine out of the children's reach. Do not permit children to play on or around the stored machine.
2. Store the machine in a dry, level area.
3. Clean grease and oil as required and protect it from the elements.

Disposal Safety

1. Improper disposal of oil or other waste may be hazardous to the environment.
2. When oil is emptied from the machine, it must be poured into a leak-proof container suitable for oil. It is not permissible to store oil in a container used for food or drink, in order to avoid the oil being consumed by mistake and causing serious injury. It is prohibited to spill oil on the ground, or pour it into a drain or anywhere leading to a water source.
3. Discarded oil, fuel, coolant, brake fluid, filters and batteries may not be thrown away or emptied in just any way. Contact your local authority for further information.

Safety Labels

Your implement comes equipped with all safety labels in place. They were designed to help you safely operate your implement. Read and follow their directions.

1. Keep all safety labels clean and legible.
2. Replace all damaged or missing labels.
3. When ordering new components make sure the correct safety labels are included in the request.
4. Refer to steps below for proper label placement.
 - a) Clean surface area where label is to be placed.
 - b) Spray soapy water onto the cleaned area.
 - c) Peel backing from label and press label firmly onto the surface.
 - d) Squeeze out air bubbles with edge of a card or with a similar type of straight edge.

PRODUCT INTRODUCTION

Listed figure is common mower that may or may not be applicable to the products described in this manual.

This series mower is designed to create a beautiful, manicured look for large lawns, golf courses, and sports fields. If you want a lawn fit for a mansion, and are using a tractor, then the tool you need is a finishing mower. Finishing mowers, also called grooming mowers or finishing mowers, are able to handle far more workload than standard push or riding mowers. They are a type of rotary mower designed to give a fine, even cut, while utilizing multiple spindles. These types of mowers are perfect for quick and professional quality cuts. Finish mowers come in several sizes and attach to any tractor with a standard 3-point hitch.

Technical Data

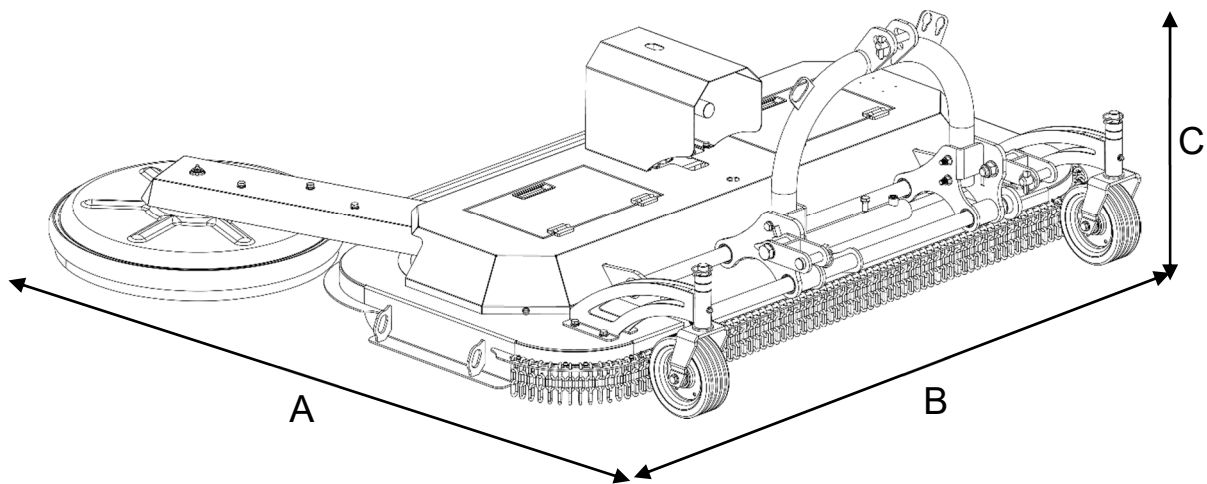

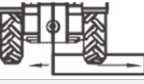



















Figure 3

Implement specification table:

Model	Unit	ME-RC60	ME-RC60H	ME-RC60-DISC	ME-RC60H-DISC
Dimension	A(cm)	135		172	
	B(cm)	160		220	
	C(cm)	74		74	
	cm	145	145	210	210
	cm	/	95-67	/	95-67
	cm	/	68-94	/	68-122
	N°	3		4	

Model	Unit	ME-RC60	ME-RC60H	ME-RC60-DISC	ME-RC60H-DISC
	HP	25-50			
	HP	30			
	RPM	540			
	CAT	I			
	N	3		4	
	KG	267	290	317	341

Model	Unit	ME-RC72	ME-RC72H	ME-RC72-DISC	ME-RC72H-DISC
Dimension	A(cm)	138		180	
	B(cm)	190		240	
	C(cm)	74		74	
	cm	175	175	228	228
	cm	/	110-82	/	110-82
	cm	/	83-109	/	83-137
	N°	3		4	
	HP	30-50			
	HP	30			
	RPM	540			

Model	Unit	ME-RC72	ME-RC72H	ME-RC72-DISC	ME-RC72H-DISC
	CAT	1			
	N	3			4
	KG	288	312	341	365

Implement Identification

The identification nameplate is affixed to the frame of each implement. It contains: the Manufacturer, Type, Serial Number, Model Number, Weight. The nameplate (Shown in the below) is for reference only and is based on the real thing.

MATENG

TYPE <input style="width: 80%;" type="text"/>	YEAR <input style="width: 80%;" type="text"/>
TYPE <input style="width: 80%;" type="text"/>	ANNÉE <input style="width: 80%;" type="text"/>
SERIAL NO. <input style="width: 80%;" type="text"/>	WEIGHT <input style="width: 80%;" type="text"/>
N° DE SÉRIE <input style="width: 80%;" type="text"/>	POIDS <input style="width: 80%;" type="text"/>

Toll Free: 1-866-718-4746
 info@mateng.ca www.mateng.ca

UNPACKING

After unpacking, please check the components shown in **Figure 4**. If you have any problem, please contact us freely.

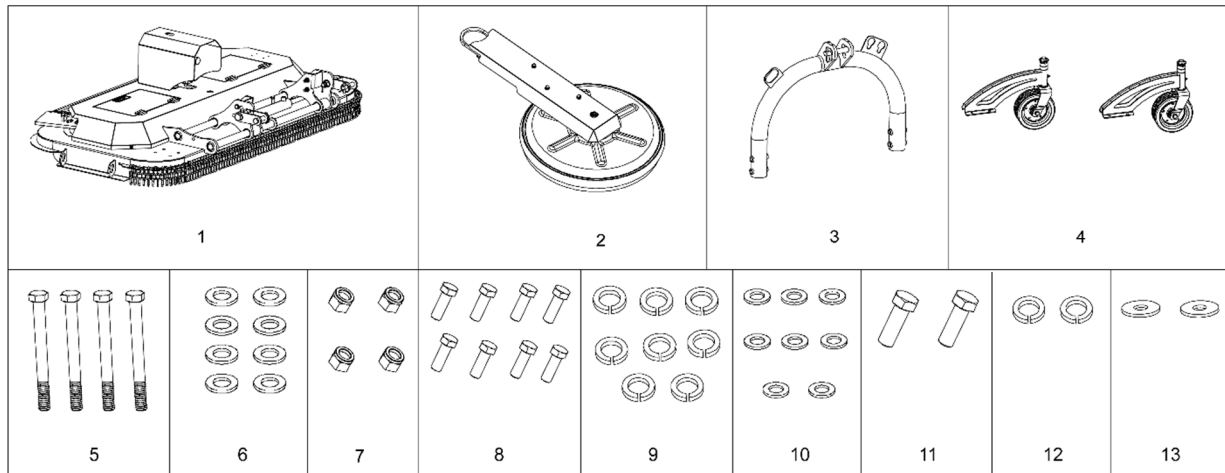

Figure 4

Unpacking parts description list:

Item	Specification	Description	Qty.	Packing
1	/	Core frame	1	Single pack
2	/	Disc component	1	Single pack
3	/	Hitch component	1	Single pack
4	G05001A21000-000	Tire component	2	Single pack
5	GB/T5782-M12×120-8.8-EP•Zn	Hex. bolt	4	Bale
6	GB/T95-12-EP•Zn	Flat washer	8	Bale
7	GB/T889.1-M12-8-EP•Zn	Locking nut	4	Bale
8	GB/T5783-M10×20-8.8-EP•Zn	Hex. bolt	8	Bale
9	GB/T93-10-EP•Zn	Spring washer	8	Bale
10	GB/T95-10-EP•Zn	Flat washer	8	Bale
11	GB/T5783-M12×35-8.8-EP•Zn	Hex. bolt	2	Bale
12	GB/T93-12-EP•Zn	Spring washer	2	Bale
13	GB/T96.2-12-EP•Zn	Flat washer	2	Bale

Tools for installation process list:

No.	Description	Specification	Conditions of Use	Qty.
1	Open end wrench	/	M10/M12 bolt fastening	2
2	Hex key	/	M10/M12 bolt fastening	1
3	Hammer	/	/	1
4	Torque wrench	10-220N.m	Measuring torque	1
5	Wind gun	1280t	Match the corresponding sleeve instead of the wrench to tighten the bolt	1

ASSEMBLY & SET-UP

Connect the Hitch to Mower

To install hitch component:

1. Bolt the hitch component (**A1**) to the inside of left and right guides (**A5&A6**) using the four hex. bolts M12*120 (**A2**), flat washers (**A3**), assemble as shown below

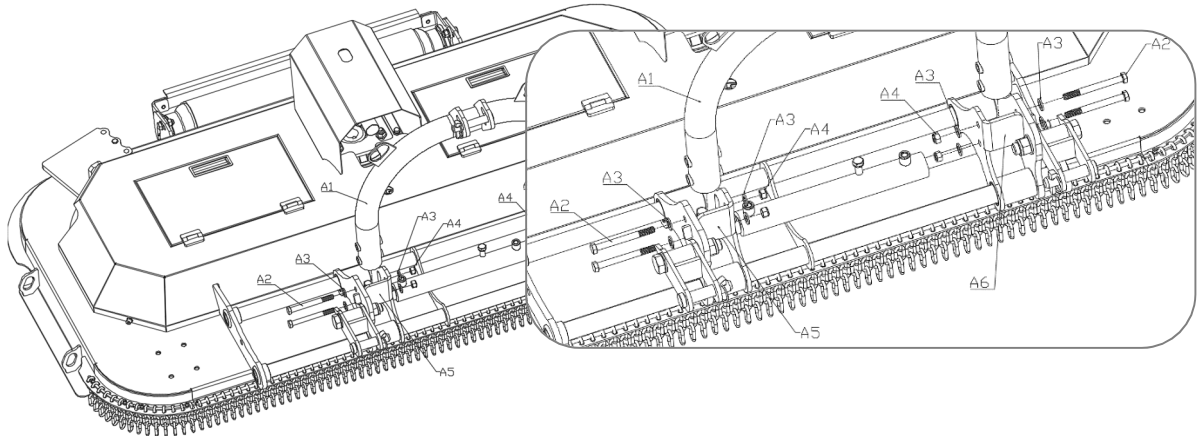

2. Tighten the bolt with hex. nuts M12 (**A4**) with flat washers (**A3**).
 - The head of the bolt should be on the outside of the guides with the flat washer, and hex. nut (**A3**) on the inside.

Tire Component Assembly

To install wheel component:

1. Bolt the left tire component (**B1**) to the left side of the hood, using four bolts M10*20 (**B2**), spring washers (**B3**) and flat washer (**B4**), assemble as shown below and tighten it.
 - The head of the bolt should be on the top of the wheel component with the spring and flat washer.
2. Repeat step 1 to install right tire component.

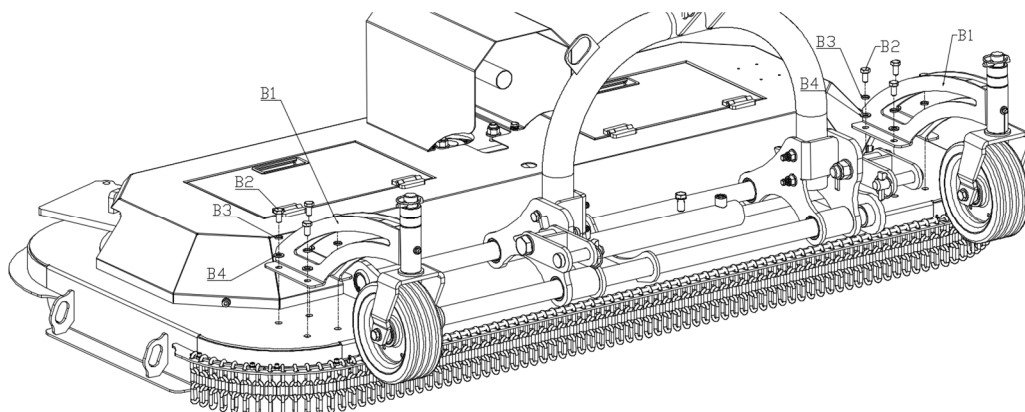

Disc Component Assembly

To install Disc component:

1. Remove the four bolts (**C2/C3/C4**) located in the top cover (**C1**), and set the top panel aside.
2. Remove the three bolts (**D10/D11/D12**) from the protection cover (**D2**) of disc component, and set the protection cover aside.
3. Bolt the disc component with out protection cover to the swing panel, using hex. bolts M12*35 (**D7**), spring washers (**D8**) and flat washer (**D9**), assemble as shown below and pre-tighten it.
4. Put the belt into the top groove of pulley (**D6**).
5. Tighten the ear panel with hex. bolt (**D4**) and hex. nut (**D5**) to expand the belt.
6. Tighten the disc component, refer to step 3.
7. Bolt the protection cover (**D2**) with the opposite step 2 to tighten.
8. Bolt the top cover (**D1**) with the opposite step 1 to tighten.

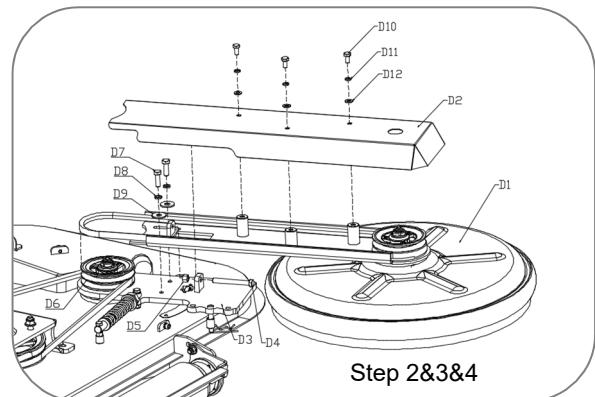
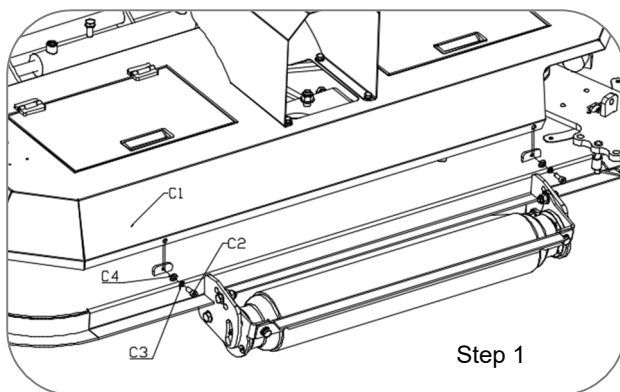

Tractor Shutdown

The following are basic tractor shutdown procedures. Follow these procedures and any additional shutdown procedures provided in your tractor Operator's Manual before leaving the operator's seat.

1. Reduce engine speed and disengage power take-off if engaged.
2. Park tractor and implement on level, solid ground.
3. Lower implement to ground or onto non-concrete support blocks.

NOTE: Due to the over running clutch, the rotor blades will continue to spin after the driveline stops.

4. Put tractor in park or set park brake, turn off engine, and remove switch key to prevent unauthorized starting.
5. Relieve all hydraulic pressure to auxiliary hydraulic lines.
6. Wait for all components to come to a complete stop before leaving the operator's seat.
7. Use steps, grab-handles and anti-slip surfaces when stepping on or off the tractor.

Tractor Hook-up

WARNING

- A crushing hazard exists while hooking-up and unhooking the implement. Keep people and animals away while approaching the implement or pulling away from the implement. Do not operate hydraulic controls while a person or an animal is nearby.
- Always follow “[Tractor Shutdown](#)” to power off.
- Tractor horsepower and hitch category should be within the required range. The lower 3-Point arms must be stabilized to prevent side-to-side movement.

Note:

- This mower is featured with a hitch design. It can be attached to the rear of a tractor.
- The upper clevis has slots to compensate for uneven ground and to keep the roller in contact with the ground. After setting the work height, adjust the length of the top center link until hitch pin is close to the rear of the slot to ensure that the mower will work correctly.
- The lower arms of a 3-point hitch for an offset/vertical mower has one end longer than the other to accommodate the offset design of the mower. This allows the mower to reach areas that a center-mounted mower cannot, such as along fence lines or ditches.

To hitch the cutter to tractor:

1. Move drawbar ahead or remove if required.
 - Be certain tractor drawbar does not interfere.
2. Remove R pin (2) and top bolt (1) from the hitch component of finishing mower.
3. Connect the top arm of tractor via top bolt and R pin to mower.
4. Remove the R pins and low bolt (3) of left and right low hitch points
5. Connect the two low arms of tractor via R pins to mower.

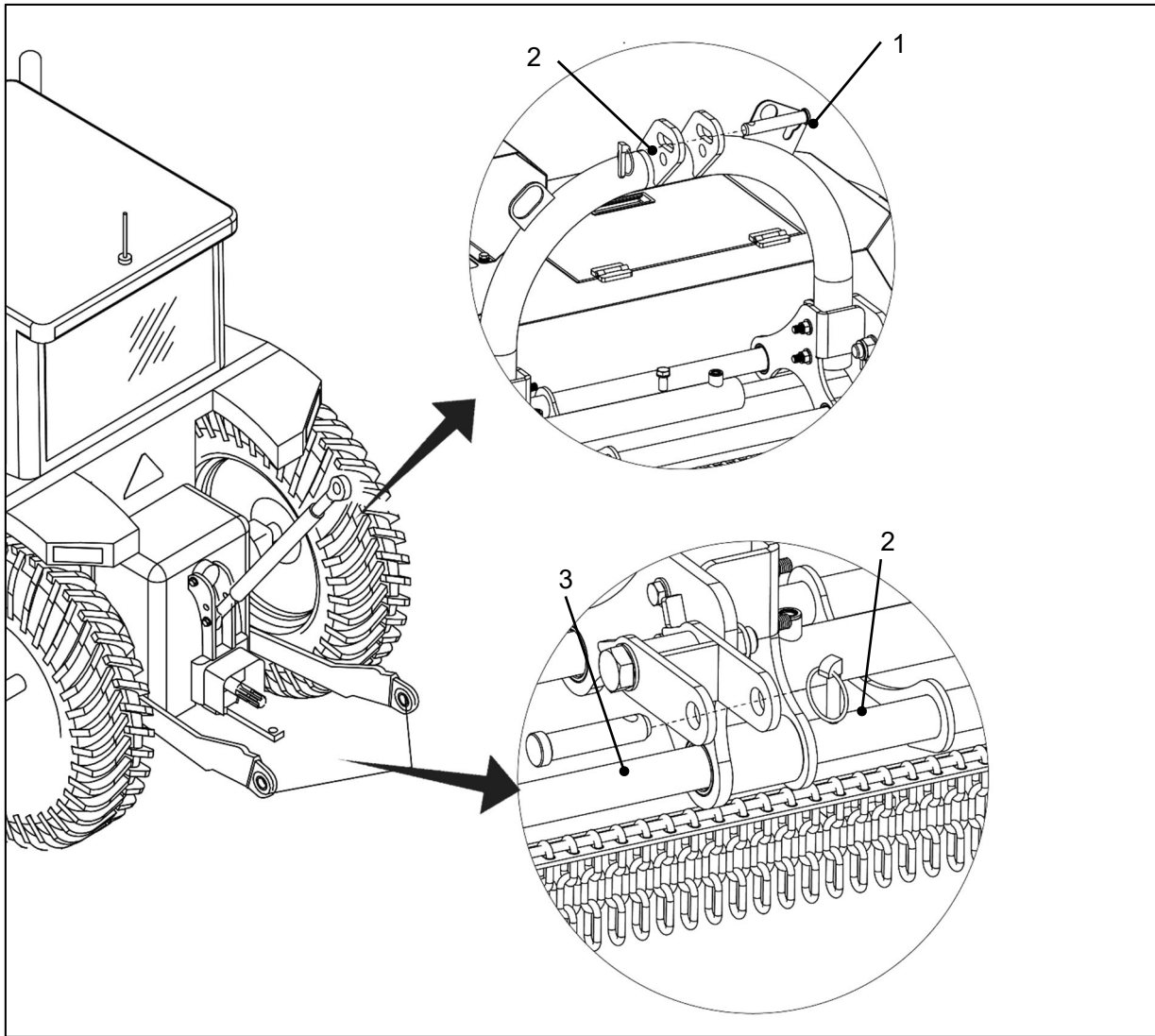

Figure 4

Driveline Installation

Listed below are common practices that may or may not be applicable to the products described in this manual.

Note: There are 3 types of PTO shafts available.

DANGER

- Do not engage tractor PTO while hooking-up and unhooking the prop shaft or stand near a rotating prop shaft. A person's body and/or clothing may get entangled to cause severe injury.
- Do not use a power take-off adapter. The adapter will increase strain on the tractor's power take-off shaft causing possible damage to shaft and driveline. It will also defeat the purpose of the tractor's power take-off shield.

- Make certain driveline yokes are securely fastened at each end. A loose yoke can work free allowing the driveline to rotate uncontrollably.

Type A shaft has interchangeable ends for installation;

Type B shaft shall have the end where safety pin locates connected with the implement;

Type C shaft shall have end where the clutch locates connected with the implement.

Type D shaft shall have end where the wide angle joint locates connected with the tractor.

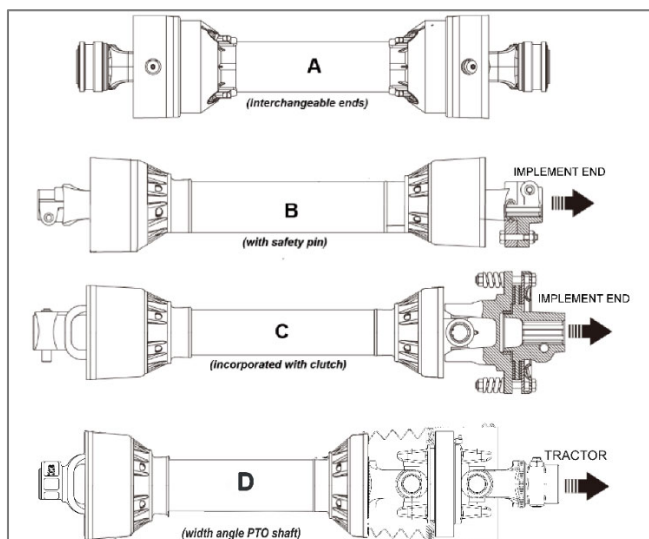

Figure 5

1. Park tractor on a level surface. Slowly engage tractor 3-Point lift lever to raise Mowers until gearbox shaft is in line (level) with tractor PTO shaft.
2. Support Mowers deck at this height with support jacks or blocks to keep Mowers from drifting down.
3. Place gear selector in park, set park brake, shut tractor off, and remove switch key.
4. Slide inner yoke (implement end) of driveline onto the gearbox. Secure driveline with yoke locking device.
5. Slide outer yoke of driveline over the tractor PTO shaft. Secure driveline with yoke locking device
6. If the driveline is too long and does not fit between tractor and gearbox, skip to **Customize Driveline** to shorten the driveline.
7. The driveline should now be moved back and forth to ensure secured connection at both ends. Reattach any end that is loose. Go to **Driveline Length Check** to ensure proper accommodation.
8. Hook driveline safety chain on the tractor end of driveline to the tractor. Re-latch safety chain to the driveline shield.
9. Hook driveline safety chain on the Mowers end of driveline to the Mowers frame. Re-latch safety chain to the driveline shield.

Driveline Length Check

Before operating the Mower, ensure that the size of driveshaft is adequate. The driveshaft supplied with the machine has a standard length, therefore it may need an adaptation of the length, depending of the tractor which the Mower is attached with.

Maximum compressed position

The power take-off shaft and gearbox input shaft must be aligned and level with each other when checking driveline minimum length. A driveline that is too long can damage tractor and implement. Hold inner and outer drivelines parallel to each other as shown and measure distance **L1**:

1. If **L1** is less than 1" (2.5 cm), skip to [Customize Driveline](#) to shorten the driveline.
2. If **L1** is greater than or equal to 1" (2.5 cm), skip to [Maximum Extended Position](#) below.

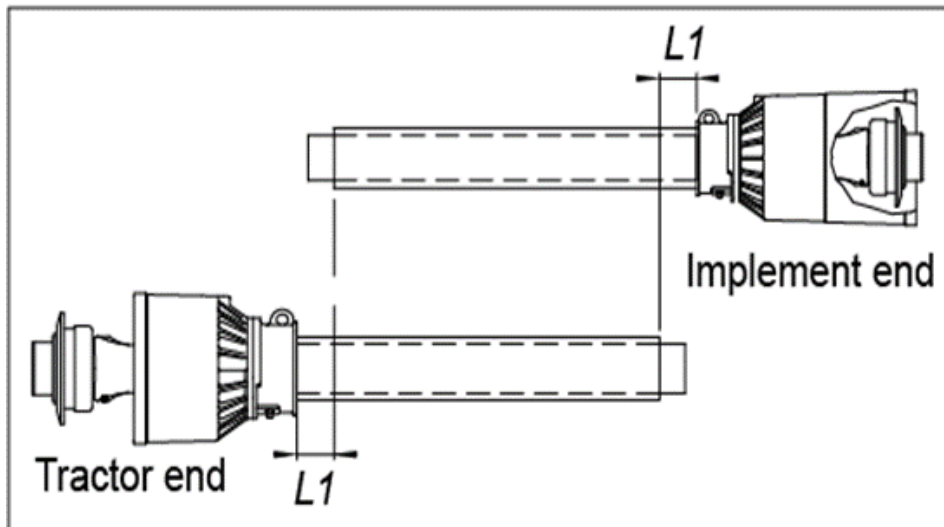

Figure 6

Maximum Extended Position

The driveline maximum allowable length must, when fully extended, have a minimum overlap (**L2**) of profile tubes by not less than 1/3 the free length with both inner and outer profile tubes being of equal length.

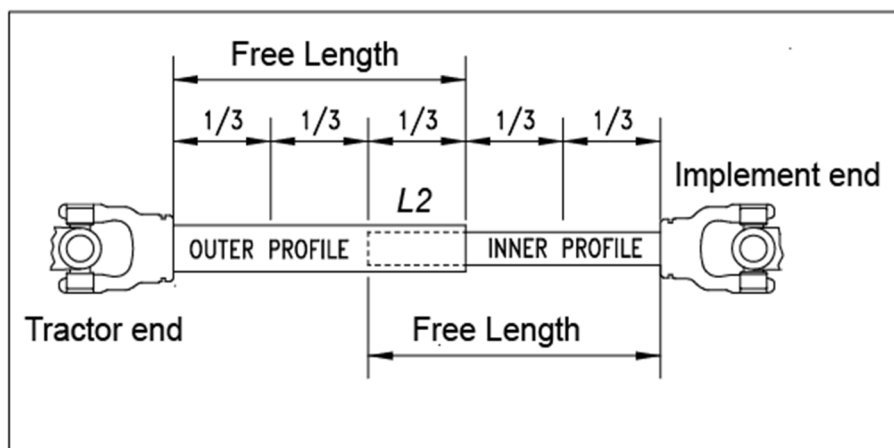

Figure 7

Customize Driveline

1. Un-hook driveline from tractor PTO shaft and pull outer and inner drivelines apart.
2. Re-attach outer driveline to tractor PTO shaft. Pull on inner and outer drivelines to be sure universal joints are properly secured.
3. Hold inner and outer drivelines parallel to each other:
 - a. Measure 1" (2.5 cm) ("**L1**" dimension) back from outer driveline universal joint shield and make a mark at this location on the inner driveline shield.
 - b. Measure 1" (2.5 cm) ("**L1**" dimension) back from the inner driveline universal joint shield and make a mark at this location on the outer driveline shield.
4. Remove driveline from tractor and gearbox shafts.
5. Measure from end of inner shield to scribed mark ("**X**" dimension). Cut off inner shield at the mark. Cut same amount off the inner shaft ("**X1**" dimension).
6. Measure from end of outer shield to scribed mark ("**Y**" dimension). Cut off outer shield at the mark. Cut same amount off the outer shaft ("**Y1**" dimension).
7. Remove all burrs and cuttings.
8. Apply multi-purpose grease to the inside of the outer shaft and reassemble the driveline.

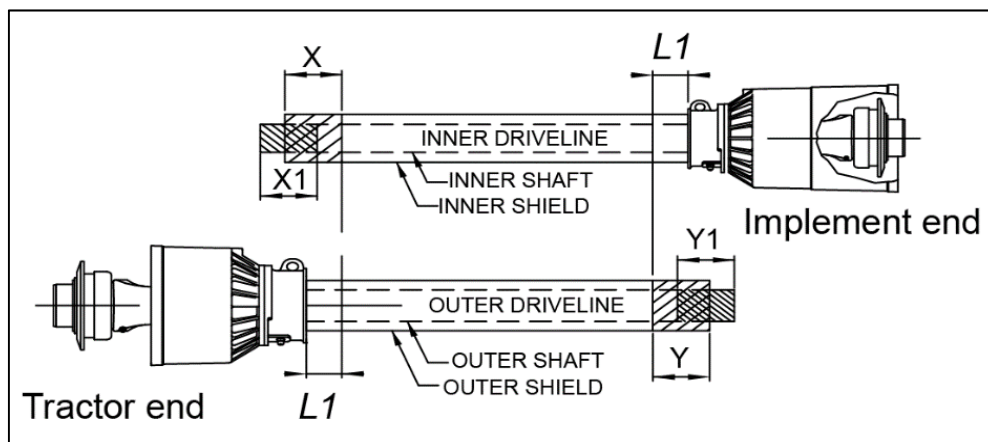

Figure 8

Driveline Interference Check

Lowly engage tractor 3-Point control lever to lower Mowers while checking for sufficient tongue clearance. Move tongue ahead, aside, or remove if required.

1. Raise and lower implement to find maximum extended driveline length. Check to make certain the driveline does not exceed the maximum allowable length and 25° up or down.
2. If needed, set tractor 3-Point lift height to keep driveline from exceeding the maximum allowable length and 25° up or down.

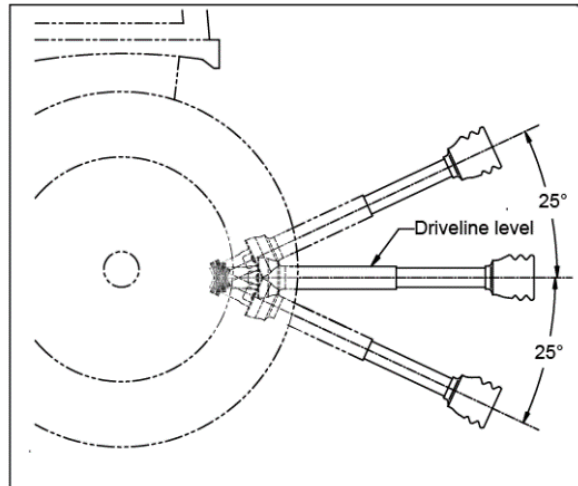

Figure 9

Note: If you have any problem during operation, please contact us for supporting!

OPERATION

General Operating Instructions

Now that you have familiarized yourself with the Operator's Manual, completed the Operators Checklist.

It's now time to do a running operational safety check. If at any time during this safety check you detect a malfunction in either the mower or tractor shut the tractor off immediately, remove the key, and make necessary repairs or adjustments before continuing on.

Make sure the tractor's park brake is engaged, the tractor's PTO is disengaged, and the mower is resting on the ground. Start the tractor and then back the tractor throttle off till the engine is at low idle. With the tractor's rear hydraulic lift control lever, raise the mower to transport position making sure that the PTO shaft is not in a bind and does not come in contact with the mower frame. Lower the unit to Crushing position and, with the tractor still at low idle, engage the PTO. If everything is running smoothly at this point increase the engine rpm until the tractor's engine reaches full PTO operating speed which will be 540 rpm. Slowly raise the cutter to transport height to make sure the driveline does not bind or chatter. Then return the engine to low idle, disengage PTO, and position the adjustable stops on the tractor's hydraulic lift lever control console so the cutter can be consistently returned to the same Crushing and transport height.

You should now be ready to move to the Crushing site to begin working. You should have inspected and should only be Crushing in an area you are familiar with which is relatively free of debris and unseen objects. Never assume an area is clear. In the event you do strike an object, stop the tractor and mower immediately to inspect the rotor and make any necessary repairs before resuming operation. It pays to inspect a new area and to develop a plan before cutting.

Recommended working speed is less than 4 mph and you will need to maintain tractor PTO speed to produce a clean cut so make a tractor gear and range selection that will maintain this combination. Generally the quality of cut will be better at lower ground speeds and crushing denser ground cover or heavier brush may create the need to slow down. Always cut downward on slopes and avoid crossing the face of steep slopes. Avoid sharp drops and cross diagonally through dips to prevent hanging up the tractor and Mowers. Slow down in turns and avoid sharp turns if at all possible. Remember to look back often.

Now you're prepared and well briefed so let's begin Cutting. Reduce the tractor's engine rpm, make sure the mower is on the ground and in Crushing position, engage the PTO, raise the engine rpm to the appropriate PTO speed, and begin working. Operators must plan a head and choose a Crushing route that allows safe turns. Try increasing or decreasing ground speed to determine the effect on quality of cut.

! CAUTION

Engage parking brake, shut off tractor, remove key, and disengage PTO before making any adjustments!

! CAUTION

Ensure mower with special supports if it is necessary to lift mower off the ground to make adjustments! If not supported, the mower could fall causing serious injury to those present.

Checklist before Operation

CAUTION

Hazard control and accident prevention are dependent upon the awareness, concern, prudence, and proper training involved in the operation, transport, storage, and maintenance of the cutter. Therefore, it is absolutely essential that no one operates the machine without first having read, fully understood, and become totally familiar with the Operator's Manual. Make sure all operators have completed the Checklist below.

Before operating the machine, the following steps should be inspected carefully:

1. Before starting up the machine, check and lubricate all grease points, on the machine and drive shaft. Check the oil level in the gearbox. Add as required.
2. Use only an agricultural tractor with horsepower within limits of the implement.
3. Check that the machine is properly attached to the tractor. Be sure retainers are used on the mounting pins.
4. Be sure extra weights are mounted on the front of the tractor, if required.
5. Check that the tractor PTO shaft turns freely and that the machine driving shaft can telescope easily.
6. Check the blades. Be sure they are not damaged or broken and swing freely in their mount. Repair or replace as required.
7. Check and tighten the blade bolts.
8. Check for entangled material in all rotating parts. And remove them.
9. Install and secure all guards, hook and covers before starting.
10. Before installing the PTO ensure the engine is stopped and the PTO shaft is in safe working order.
11. All other people shall leave the area before connecting the driving power from the tractor.
12. Before cleaning, repairing and lubricating the machine, stop the motor and take the key away with you.
13. When the PTO shaft is not connected with the tractor, support it through the frame to protect it from lying in the dirt.
14. Don't approach the machine when it is operating.

Levelling the Mower

Levelling adjustments are made at the tractor's 3-Point lower arms and top center link.

1. Park tractor and Mowers on a flat level surface.
2. Raise Mowers with the tractor's Hydraulic 3-Point lift slowly until the unit is about 1 to 2" above the ground.
3. Ensure that the lower arms are stabilized to prevent excessive side movement.

4. Place a spirit level on the top cover running from left to right and adjust one of the lower 3-Point arms up or down until the Mowers is level from left to right.
5. Adjust tractor's top center link to place the upper hitch pin vertically above or slightly behind the lower hitch pins.
6. Slowly operate the tractor's 3-Point hydraulic control up and down to check for clearance between the tires, frame, drawbar.

Adjusting Wheel Height

CAUTION

The wheels' height must be adjusted into the same position.

The blades must never be less than 1" (2.5 cm) from the ground.

To adjust wheel height

Park tractor and implement on a flat, level surface.

1. Lower tractor lift arms to bring the roller in contact with the ground and make sure the blades are parallel with the ground.
 2. Shut tractor down according to procedures mentioned in tractor manual.
 3. Raise and secure the implement with solid and firm support blocks.
 4. Remove the R pin(3), Plain washer (2) , Spacers(1)
 5. Fit the upper Spacers in a suitable position underneath and secure with fixings.
 6. Repeat the above steps to adjust the other wheels.
- Make sure the all wheels are the same, otherwise the cutting procedures will fail.

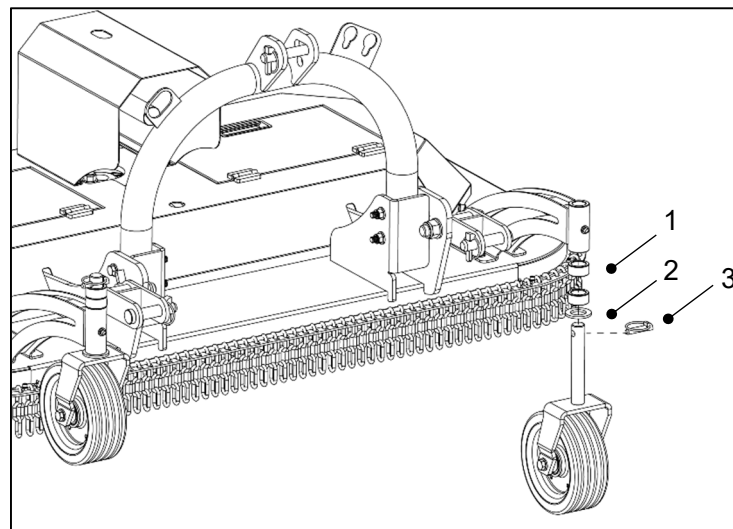

Figure 10

Starting the Machine

WARNING

- The rotary cutter must only be in the working position while moving forward and must be raised when backing-up. Operating the rotary cutter in the working position while backing-up can seriously damage it.
- Never use the rotary cutter with the tractor straddling a ditch.
- Only operate the rotary cutter inclined when in the lateral extended configuration. When the rotary cutter is in the center configuration, only operate it horizontally.
- Make sure that there are no persons or animals in the vicinity.

DANGER

To avoid tractor overturning hazard

- When working on inclined surfaces (ditches, slopes etc.), as the combined weight of the tractor and rotary cutter may cause the tractor to overturn.
- Lightweight tractors with rear attached implements may need weights added to the front to maintain steering control.
- Consult your tractor Operator's Manual to determine proper weight requirements and maximum weight limitations.
- Survey any incline surface the tractor will be traveling on for holes and low depressions in the ground that the tractor wheel can drop into suddenly causing the tractor to overturn unexpectedly. Avoid such drop-offs.

Inspection before Starting

Before starting the machine, check and adjust the following items:

1. Gearbox oil level.
2. Grease nipples on bearings and PTO shaft.
3. All bolts, nuts and screws.

Operation the Machine

To operate the machine:

1. Stop traveling forward, disengage power take-off, and raise the cutter off the ground.
2. Back-up with the cutter above ground.
3. Lower the cutter to the working position, engage power take-off, and continue cutting while traveling forward.

Note: if you have any problem during operation without description, please contact us freely!

SERVICE AND MAINTENANCE

General Service

The period recommended is based on normal operating conditions. Severe or unusual conditions may require more frequent service.

Each 4 hours of work:

Check and tighten nuts and bolts.

Grease with lithium based grease when it is indicated by the symbol GREASE.

After 50 hours of work:

Check and fill the gearbox to the required level, using oil type SAE EP 90W.

Gearbox Maintenance

The oil should be drained out and replaced after the first 50 hours of operation. Then the oil should be changed every 250 hours.

Drain oil from the gearbox thoroughly. Check and clean it. Fill with new gear oil up to the dedicated oil level.

The draining procedure is as follows: remove the draining bolt under the gear box, so that the oil drains off. After the oil is drained out, put the plug back and fill with gear oil up to the dedicated oil level.

PTO Shaft Maintenance

It is recommended to lubricate the PTO shaft with multi-purpose grease after every 8 to 10 hours of use during heavy use. The PTO shaft is designed to telescope to allow for dimensional changes as the machine goes through its operating range. A tubular guard encloses the driving components and is designed to turn relative to the driving components. The shaft should telescope easily and the guard turn freely on the shaft at all times. Annual disassembly, cleaning and lubrication is recommended to insure that all components function as intended. To maintain the shaft, follow this procedure:





1. Remove the shaft from the machine.
2. Pull shaft apart.
3. Use a screwdriver to pry the tabs out of the sleeves on each end.
4. Pull the shaft out of the plastic tubular guard.

5. Use a solvent to clean the male and female portions of the telescoping ends.
6. Apply a light coat of grease to each end.
7. Clean the grooves on each end where the tabs are located. Clean each tab also.
8. Apply a light coat of grease to each groove.
9. Insert the shaft into its respective guard and align the slots with the groove.
10. Insert the tabs through the slots and seat in the groove.
11. Check that each guard turns freely on the shaft.
12. Assemble the shaft.
13. Check that the shaft telescopes easily.
14. Replace any components that are damaged or worn.
15. Install the shaft on the machine.



Lubrication Parts





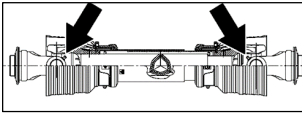
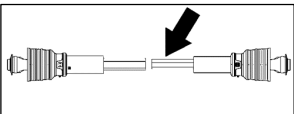
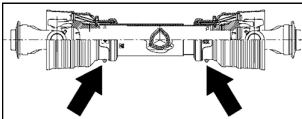

Listed lubrication parts are common practices that may or may not be applicable to the products described in this manual.

Lubrication legend list:

Name	Multi-purpose spray lube	Multi-purpose grease lube	Multi-purpose oil lube	Intervals in hours at which lubrication is required
Image				

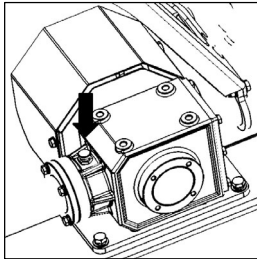
Lubrication parts list:

Interval	Type	Name	Parts Image	Remark
	 Multi-purpose Grease	Driveline Shaft U-Joints		Quantity - 4 to 8 Pumps
		Driveline Profiles		Quantity - Clean & coat inner profile tube of driveline with a light film of grease and then reassemble.
		Inner Tube Bearings		Quantity - As Required

Interval	Type	Name	Parts Image	Remark
	 SAE EP 90W Gear Lube	Gearbox		Add visual to the center of the gear oil Reinstall plugs and tighten. Do not overfill! Should your gearbox require service, take it to your Manufacturer dealer.
	 Multi- purpose Grease	Other parts	 If the GREASE labels () are posted on the machine, you need to lubricate it regularly. Recommend lubrication interval is 25hours.	

Tightening Torque

Please follow the table below to identify the torque value as required.

Torque Values Chart for Common Bolt Sizes													
Bolt Size (inches)	Bolt Head Identification						Bolt Size (Metric)	Bolt Head Identification					
	Grade 2		Grade 5		Grade 8			Class 5.8		Class 8.8		Class 10.9	
in-tpi ¹	N · m ²	ft-lb ³	N · m	ft-lb	N · m	ft-lb	mm x pitch ⁴	N · m	ft-lb	N · m	ft-lb	N · m	ft-lb
1/4" - 20	7.4	5.6	11	8	16	12	M 5 X 0.8	4	3	6	5	9	7
1/4" - 28	8.5	6	13	10	18	14	M 6 X 1	7	5	11	8	15	11
5/16" - 18	15	11	24	17	33	25	M 8 X 1.25	17	12	26	19	36	27
5/16" - 24	17	13	26	19	37	27	M 8 X 1	18	13	28	21	39	29
3/8" - 16	27	20	42	31	59	44	M10 X 1.5	33	24	52	39	72	53
3/8" - 24	31	22	47	35	67	49	M10 X 0.75	39	29	61	45	85	62
7/16" - 14	43	32	67	49	95	70	M12 X 1.75	58	42	91	67	125	93
7/16" - 20	49	36	75	55	105	78	M12 X 1.5	60	44	95	70	130	97
1/2" - 13	66	49	105	76	145	105	M12 X 1	90	66	105	77	145	105
1/2" - 20	75	55	115	85	165	120	M14 X 2	92	68	145	105	200	150
9/16" - 12	95	70	150	110	210	155	M14 X 1.5	99	73	155	115	215	160
9/16" - 18	105	79	165	120	235	170	M16 X 2	145	105	225	165	315	230
5/8" - 11	130	97	205	150	285	210	M16 X 1.5	155	115	240	180	335	245
5/8" - 18	150	110	230	170	325	240	M18 X 2.5	195	145	310	230	405	300
3/4" - 10	235	170	360	265	510	375	M18 X 1.5	220	165	350	260	485	355
3/4" - 16	260	190	405	295	570	420	M20 X 2.5	280	205	440	325	610	450
7/8" - 9	225	165	585	430	820	605	M20 X 1.5	310	230	650	480	900	665
7/8" - 14	250	185	640	475	905	670	M24 X 3	480	355	760	560	1050	780
1" - 8	340	250	875	645	1230	910	M24 X 2	525	390	830	610	1150	845
1" - 12	370	275	955	705	1350	995	M30 X 3.5	960	705	1510	1120	2100	1550
1-1/8" - 7	480	355	1080	795	1750	1290	M30 X 2	1060	785	1680	1240	2320	1710
1-1/8" - 12	540	395	1210	890	1960	1440	M36 X 3.5	1730	1270	2650	1950	3660	2700
1-1/4" - 7	680	500	1520	1120	2460	1820	M36 X 2	1880	1380	2960	2190	4100	3220
1-1/4" - 12	750	555	1680	1240	2730	2010							
1-3/8" - 6	890	655	1990	1470	3230	2380							
1-3/8" - 12	1010	745	2270	1670	3680	2710							
1-1/2" - 6	1180	870	2640	1950	4290	3160							
1-1/2" - 12	1330	980	2970	2190	4820	3560							

¹ in-tpi = nominal thread diameter in inches-threads per inch
² N · m = newton-meters
³ ft-lb = foot pounds
⁴ mm x pitch = nominal thread diameter in millimeters x thread pitch

Torque tolerance + 0%, -15% of torquing values. Unless otherwise specified use torque values listed above.
 All locknuts or lubricated fasteners: Use 75% of torque value. (i.e. 1/2"-13 GR5 = 76 ft-lb; 75% of 76 or .75 x 76 = 57 ft-lb)

- This chart is an approximate estimate of torque values.
- Always tighten hardware to these values unless a different torque value or tightening procedure is listed for a specific application.
- Fasteners must always be replaced with the same grades as specified in the manual.
- Always use the proper tool for tightening hardware; SAE for SAE hardware and Metric for Metric hardware.
- Make sure that fastener threads are clean and that you properly start thread engagement.

Replacing the Blade

Frequently check rotor blades to make sure they are in good working condition and properly secured to the rotor.

Replace worn or damaged parts with new blades.

IMPORTANT:

- Make sure that the replacement of blade with other same weight. This will be a balance of rotor spinning.
- Recommend blade is the original factory accessories.

To replace a new blade:

1. Remove the nut and flat washer from damaged blade, and set it aside.
2. Remove the damaged blade.
3. Install the new blade with washer(3) and bolt (4) , locknut(5), Blade spacer(6)
4. Tighten nut with correct torque.
5. Lubricate points.

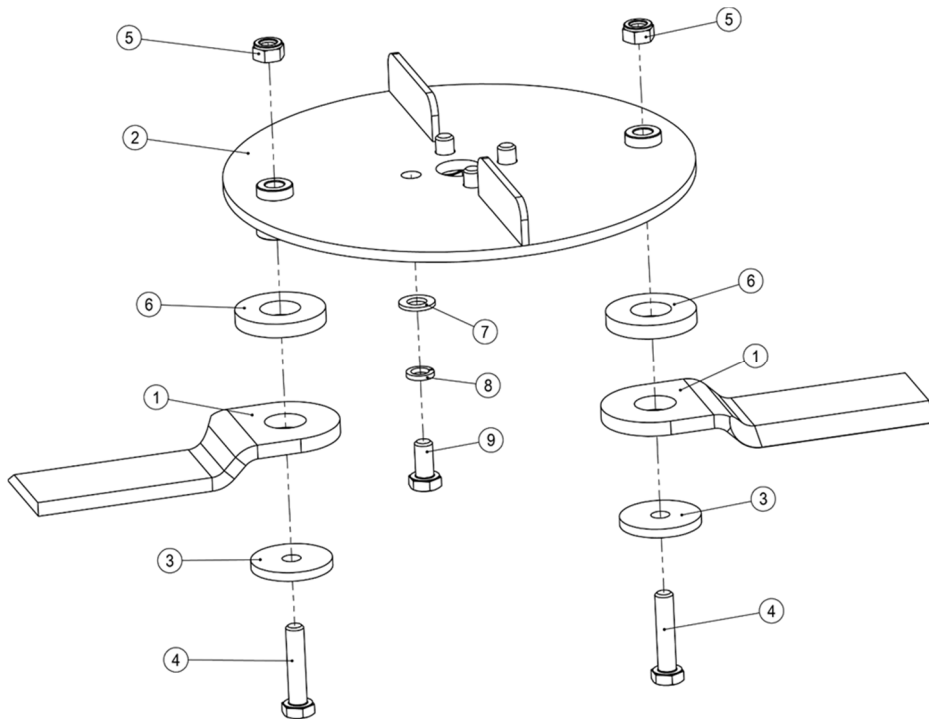

Figure 11

Note: If the images shown in the above figure are different from the machine, please check

[EXPLODED VIEW AND PARTS LIST](#).

STORAGE AND TRANSPORT

Storage

Before storage the implement, you should following the steps below:

1. Remove any dirt and grease that may have accumulated on the cutter and moving parts.
Scrape off compacted dirt from under the hood. Clean the machine inside and out so as to avoid corrosion.
2. Check rotor, blades, blade mounts, and blade bolts for wear and replace if necessary.
3. Don't spray water on the rolling bearing if you clean the machine with high pressure sprayer.
4. Check and clean the universal joint, driving belt press roller, or replace them if they are not in good condition. Lubricate wherever needed.
5. Recoat the parts rubbed and damaged for anti-corrosion.
6. Store the machine in a dry, level area.

Transport

WARNING

- Always disengage power take-off before raising cutter to transport position.
- When traveling on roadways, travel in such a way that other vehicles may pass you safely.
Always use LED lights, clean reflectors, and a slow moving vehicle sign that is visible from the back to warn operators in other vehicles of your presence.
- Always comply with all federal, state, and local laws.

Before transport the implement, you should following the steps below:

1. When raising cutter to transport position, be sure driveline does not contact tractor or cutter. If needed, adjust and set tractor 3-point lift height to limit cutter movement and to protect driveline.
2. Be sure to reduce tractor ground speed when turning, leaving enough clearance so that the cutter does not contact obstacles such as buildings, trees, fences, etc.
3. Select a safe ground travel speed when transporting from one area to another. When traveling on roadways, transport in such a way that faster moving vehicles may pass safely.
4. When traveling over rough or hilly terrain, shift tractor to a lower gear.

TROUBLESHOOTING

Listed general troubleshooting is the common malfunction that may or may not be application to the described in this manual. If you have any problem not covered in the list, please contact us for technical supporting.

General troubleshooting list:

Malfunction	Possible Cause	Solution
Significant machine vibration	Worn blades	Replace the blades
	Missing blades	
	Broken blades	
	Worn rotor support bearings	Replace the bearings
	Rotor fouled with debris	Clean rotor
	Loose parts	Tighten bolts and fasteners
	Incorrect power take-off speed	Select correct tractor power take-off speed
Excessively rapid blade wear	Blades touching the ground	Check and, if necessary, adjust cut height
Blades tear rather than cut, shredded material not distributed evenly	Ground speed too high	Reduce the speed
	Cut height too low	Adjust cut height
	Excessive build-up of material under the head	Clean the head
	Clogging	Clean the machine to remove accumulated debris
Excessive driveline noise	Insufficient greasing	Apply grease as indicated in the Maintenance section
	Worn trunnion bearing	Replace bearings
	Exceeds 25 degrees	Do not exceed 25 degrees
Driveline wear	Insufficient greasing	Apply grease as indicated in the Maintenance section
	Operating angle incorrect	Reduce the operating angle
	Overloading	Avoid overloading and do not start the machine when loaded
Breakage or deformation of the driveline	Overloading	Avoid overloading and do not start the machine when loaded

Malfunction	Possible Cause	Solution
	Operating angle incorrect	Reduce the operating angle
Unit overheating	Not enough oil in the unit	Check seals and gaskets and replace any that are damaged
		Top off the oil
	Incorrect oil type	Replace with the prescribed type of oil
	Excessive oil	Restore correct oil level
	Overloading	Observe the prescribed speed and power conditions
Lateral adjustment and/or inclination angle adjustment functions not working correctly	Hoses connected incorrectly to tractor remotes	Connect correctly
	Remotes or hydraulic pump on tractor faulty	Check and repair if necessary
	Oil leakage	Check connections and tighten correctly if
		Check hydraulic hoses and replace if necessary

EXPLODED VIEW AND PARTS LIST

MACHINE ASSEMBLY

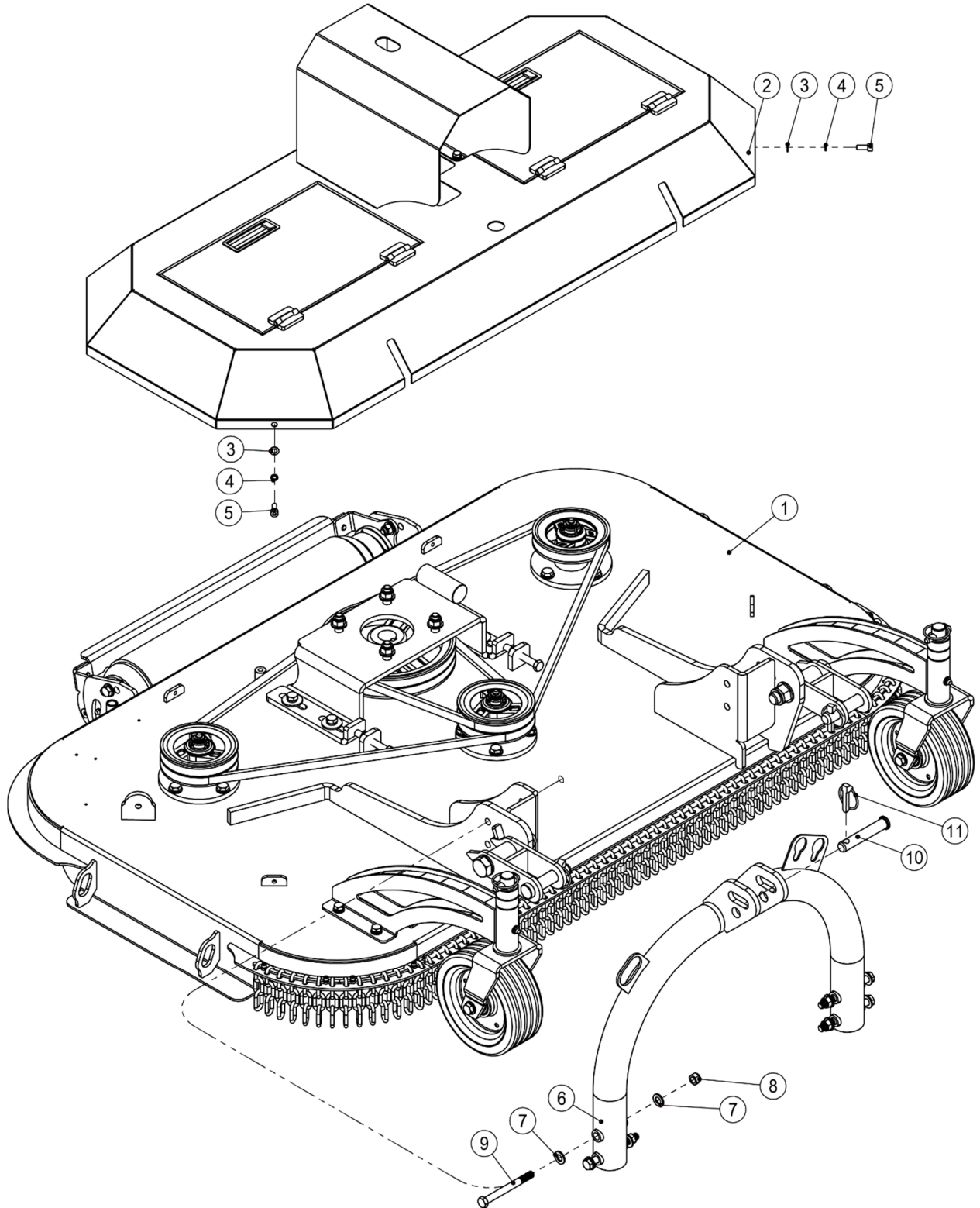

Machine (**ME-RC60/72**) assembly parts name list:

POS.	COD.	Specification	Description	60 /Qty	72 /Qty
1	2090000511	G05003A01000-000	Explosion diagram of aircraft hood	1	-
	2090000512	G05004A01000-000	Explosion diagram of aircraft hood	-	1
2	2090000513	G05003A11000-000	Cover assembly	1	-
	2090000514	G05004A11000-000	Cover assembly	-	1
3	3080100004	GB/T95-8-EP•Zn	Plain washer	4	4
4	3080500007	GB/T93-8-EP•Zn	Spring washer	4	4
5	3060100026	GB/T70.1-M8×20- 8.8	Hex. socket head cap screws	4	4
6	2020000701	G01009A12100-000	Hitch weldment	1	1
7	3080100007	GB/T95-12-EP•Zn	Plain washer	8	8
8	3050500007	GB/T889.1-M12-8-EP•Zn	Locknut	4	4
9	3040300036	GB/T5782- M12×120-8.8	Hex. head bolts	4	4
10	3120500009	MT95003	Pin	1	1
11	3120400007	GB/T4329-12-EP•Zn	Safety pin	1	1

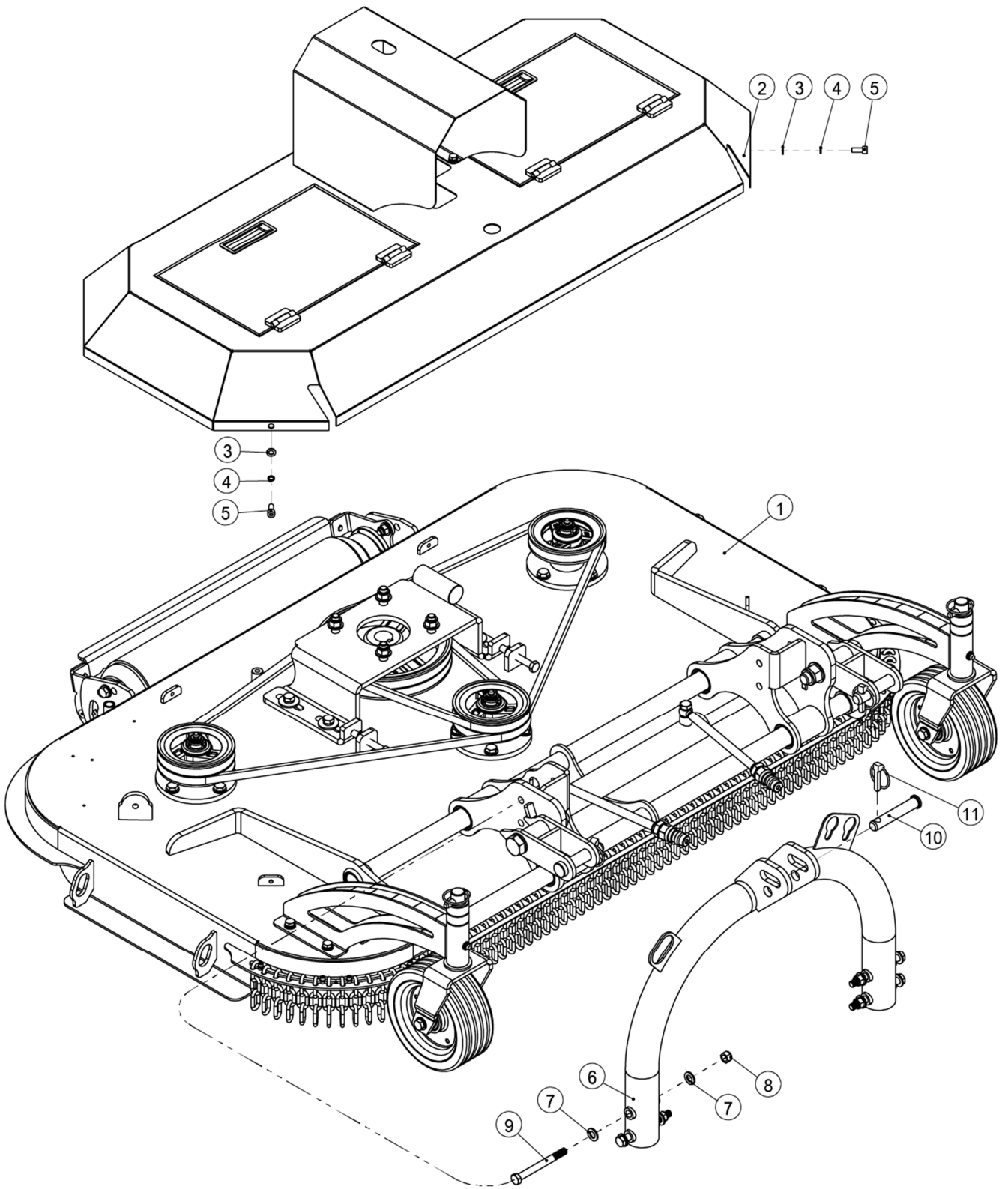

Machine (**ME-RC60H/72H**) assembly parts name list:

POS	COD.	Specification	Description	60H /Qty	72H /Qty
1	2090000515	G05005A01000-000	Explosion diagram of aircraft hood	1	-
1	2090000516	G05006A01000-000	Explosion diagram of aircraft hood	-	1
2	2090000517	G05005A11000-000	Cover assembly	1	-
2	2090000518	G05006A11000-000	Cover assembly	-	1
3	3080100004	GB/T95-8-EP•Zn	Plain washer	4	4
4	3080500007	GB/T93-8-EP•Zn	Spring washer	4	4
5	3060100026	GB/T70.1-M8×20-8.8-EP•Zn	Hex. socket head cap screws	4	4
6	2020000701	G01009A12100-000	Hitch weldment	1	1
7	3080100007	GB/T95-12-EP•Zn	Plain washer	8	8
8	3050500007	GB/T889.1-M12-8-EP•Zn	Locknut	4	4
9	3040300036	GB/T5782-M12×120-8.8-EP•Zn	Hexagon head bolts	4	4
10	3120500009	MT95003	Pin	1	1
11	3120400007	GB/T4329-12-EP•Zn	Safety pin	1	1

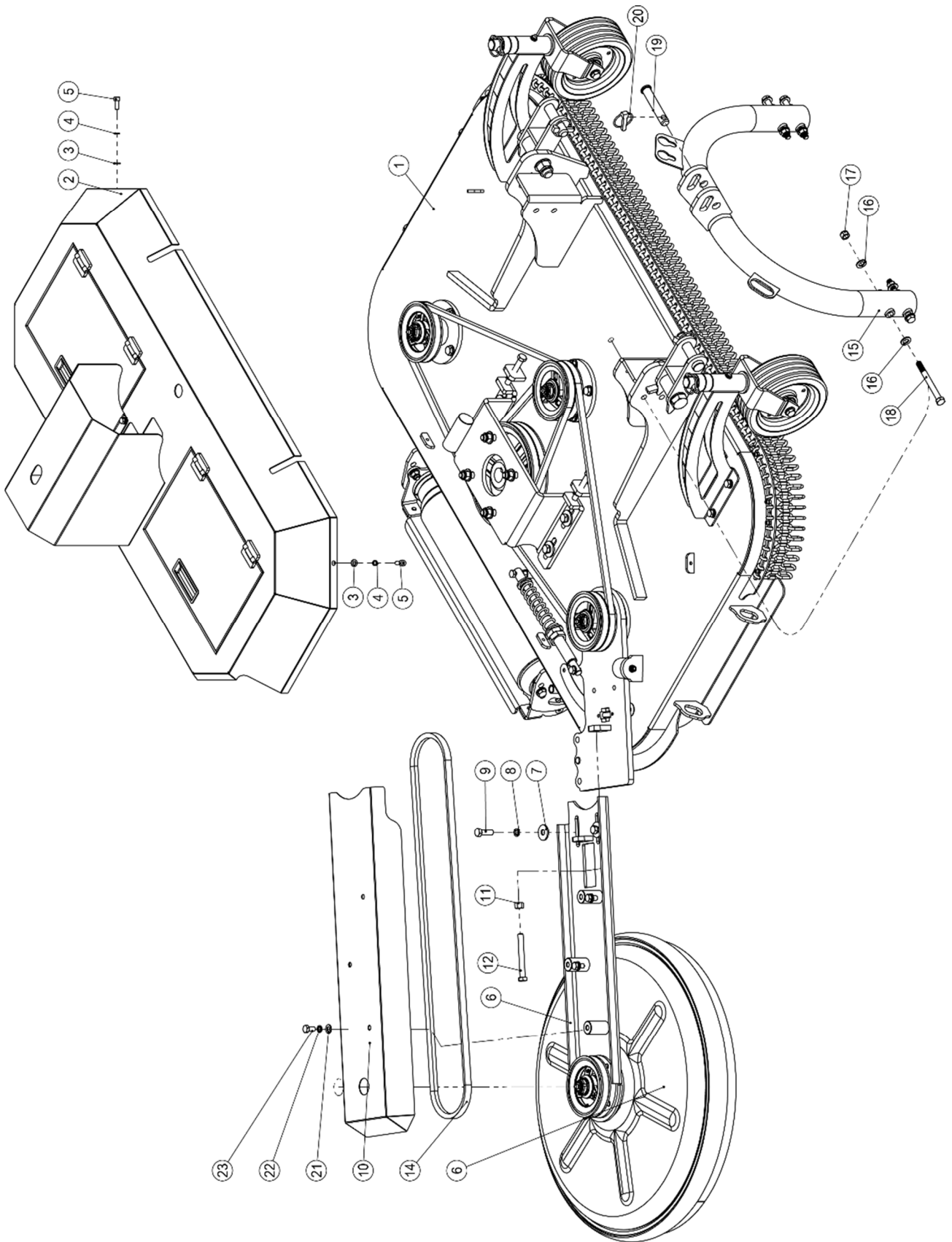

Machine (ME-RC60-DISC/70-DISC) assembly parts name list:

POS.	COD.	Specification	Description	60-DISC /Qty	72-DISC /Qty
1	2090001537	G05007A01000-000	Explosion diagram of aircraft hood	1	-

POS.	COD.	Specification	Description	60-DISC /Qty	72-DISC /Qty
1	2090001546	G05008A01000-000	Explosion diagram of aircraft hood	-	1
2	2090000509	G05007A11000-000	Cover assembly	1	-
2	2090000510	G05008A11000-000	Cover assembly	-	1
3	3080100004	GB/T95-8-EP•Zn	Plain washer	4	4
4	3080500007	GB/T93-8-EP•Zn	Spring washer	4	4
5	3060100026	GB/T70.1-M8×20- 8.8-EP•Zn	Hex. socket head cap screws	4	4
6	2090001531	G05001A27000-000	Floating cutter assembly	1	-
6	2090001541	G05002A27000-000	Floating cutter assembly	-	1
7	3080200010	GB/T96.2-12-EP•Zn	Large plain washer	2	2
8	3080500009	GB/T93-12-EP•Zn	Spring washer	2	2
9	3040100069	GB/T5783-M12×35- 8.8-EP•Zn	Full-thread hexagon bolts	2	2
10	2000000961	G05001A00000-001	Belt cowl	1	-
10	2000000962	G05002A00000-001	Belt cowl	-	1
11	3050100007	GB/T41-M12-5-EP•Zn	Hexagon nuts	1	1
12	3040100082	GB/T5783- M12×100-8.8	Full-thread hexagon bolts	1	1
13	3160300004	GATES-XPB-2000	Belt	-	1
14	3160300002	GATES-XPB1900	GATES belt	1	-
15	2020000701	G01009A12100-000	Hitch weldment	1	1
16	3080100007	GB/T95-12-EP•Zn	Plain washer	8	8
17	3050500007	GB/T889.1-M12-8-EP•Zn	Locknut	4	4
18	3040300036	GB/T5782- M12×120-8.8	Hexagon head bolts	4	4
19	3120500009	MT95003	Pin	1	1
20	3120400007	GB/T4329-12-EP•Zn	Safety pin	1	1
21	3080100006	GB/T95-10-EP•Zn	Plain washer	3	3
22	3080500008	GB/T93-10-EP•Zn	Spring washer	3	3
23	3040100041	GB/T5783-M10×20- 8.8-EP•Zn	Full-thread hexagon bolts	3	3

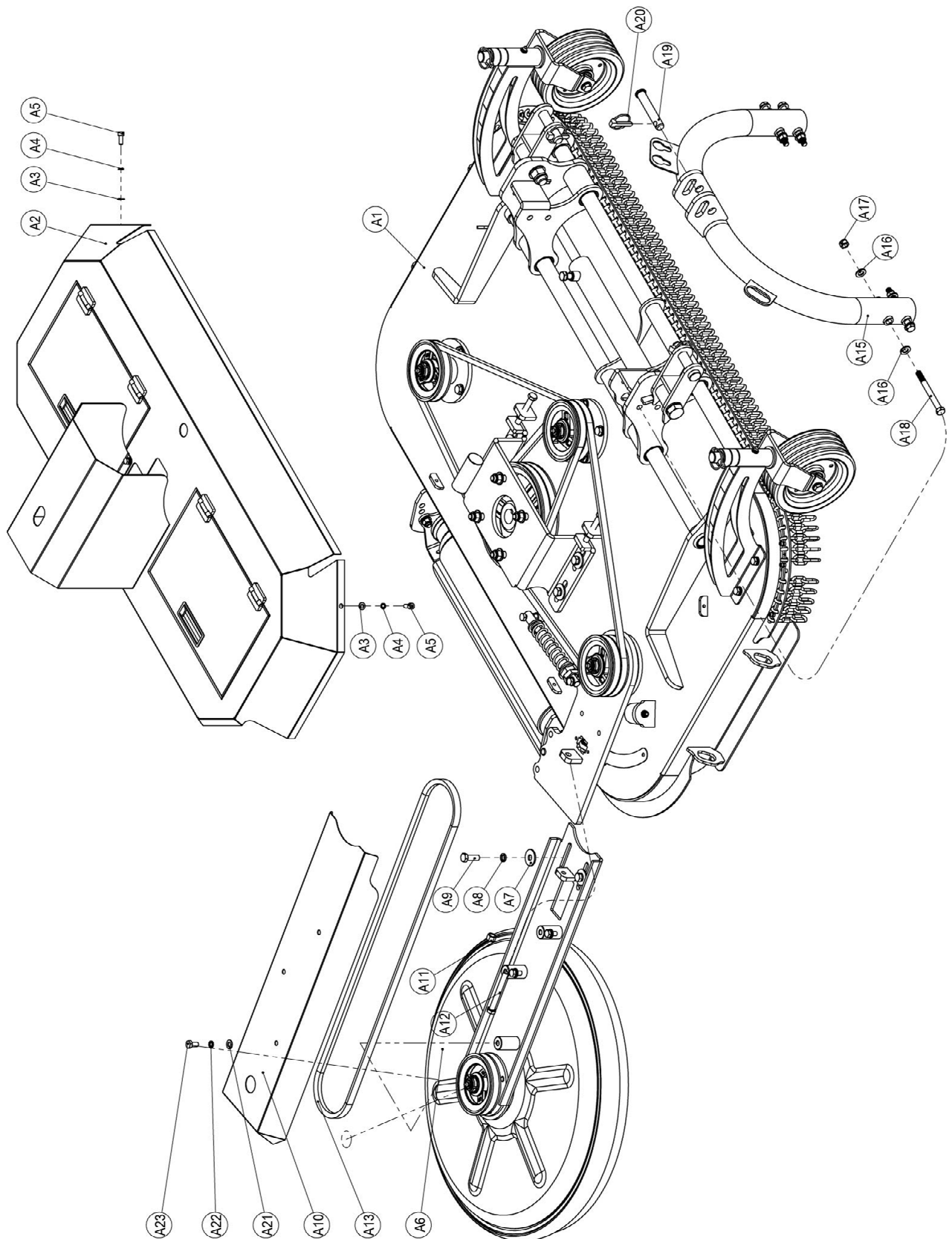

Machine (ME-RC60H-DISC/ ME-RC72H-DISC) assembly parts name list:

POS.	COD.	Specification	Description	60H-DISC /Qty	72H-DISC /Qty
A1	2090001528	G05001A01000-000	Explosion diagram of aircraft hood	1	-

POS.	COD.	Specification	Description	60H-DISC /Qty	72H-DISC /Qty
	2090001539	G05002A01000-000	Explosion diagram of aircraft hood	-	1
A2	2090000493	G05001A11000-000	Cover assembly	1	-
	2090000494	G05002A11000-000	Cover assembly	-	1
A3	3080100004	GB/T95-8-EP•Zn	Plain washer	4	4
A4	3080500007	GB/T93-8-EP•Zn	Spring washer	4	4
A5	3060100026	GB/T70.1-M8×20-8.8	Hex. socket head cap screws	4	4
A6	2090001531	G05001A27000-000	Floating cutter assembly	1	-
	2090001541	G05002A27000-000	Floating cutter assembly	-	1
A7	3080200010	GB/T96.2-12-EP•Zn	Large plain washer	2	2
A8	3080500009	GB/T93-12-EP•Zn	Spring washer	2	2
A9	3040100069	GB/T5783-M12×35-8.8	Full-thread hexagon bolts	2	2
A10	2000000961	G05001A00000-001	Belt cowl	1	-
A10	2000000962	G05002A00000-001	Belt cowl	-	1
A11	3050100007	GB/T41-M12-5-EP•Zn	Hexagon nuts	1	1
A12	3040100082	GB/T5783-M12×100-8.8	Full-thread hexagon bolts	1	1
A13	3160300002	GATES-XPB1900	belt	1	-
	3160300004	GATES-XPB-2000	Belt	-	1
A15	2020000701	G01009A12100-000	Hitch weldment	1	1
A16	3080100007	GB/T95-12-EP•Zn	Plain washer	8	8
A17	3050500007	GB/T889.1-M12-8-EP•Zn	Locknut	4	4
A18	3040300036	GB/T5782-M12×120-8.8	Hexagon head bolts	4	4
A19	3120500009	MT95003	Pin	1	1
A20	3120400007	GB/T4329-12-EP•Zn	Safety pin	1	1
A21	3080100006	GB/T95-10-EP•Zn	Plain washer	3	3
A22	3080500008	GB/T93-10-EP•Zn	Spring washer	3	3
A23	3040100041	GB/T5783-M10×20-8.8	Full-thread hexagon bolts	3	3

HOOD COMPONENT

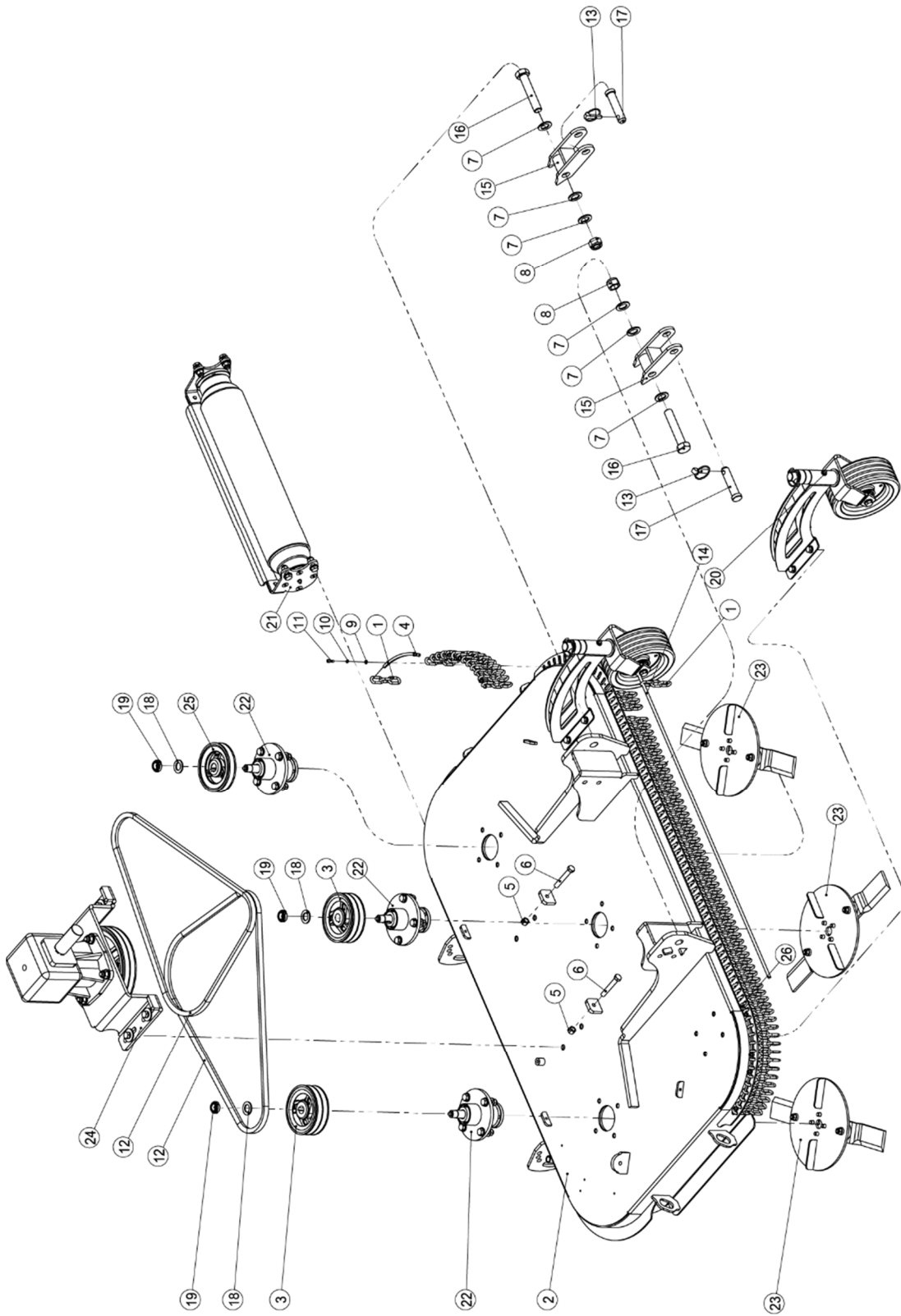

Hood component (**ME-RC60/72**) parts name list:

POS.	COD.	Specification	Description	60 /Qty	72 /Qty
1	3130100014	6×28×20-3	Galvanized chain	78	90
2	2020001193	G05003A01100-000	Hood weldment	1	-
2	2020001194	G05004A01100-000	Hood weldment	-	1
3	3160400004	SPB132-2-2-22-HT200-O	Pulley	2	2
4	2000000590	G05001A01000-001	Chain fixing plate	4	4
5	3050100007	GB/T41-M12-5-EP•Zn	Hexagon nuts	2	2
6	3040100079	GB/T5783-M12×80-8.8-EP•Zn	Full-thread hex. bolts	2	2
7	3080100012	GB/T95-22-EP•Zn	Plain washer	6	6
8	3050500012	GB/T889.1-M22-8-EP•Zn	Locknut	2	2
9	3080100002	GB/T95-5-EP•Zn	Plain washer	8	8
10	3080500005	GB/T93-5-EP•Zn	Spring washer	8	8
11	3060100004	GB/T70.1-M5×16-8.8-EP•Zn	Hex. socket cap screws	8	8
12	3160300001	GATES-XPB1800	Belt	2	-
12	3160300003	GATES-XPB1965	Belt	-	2
13	3120400007	GB/T4329-12-EP•Zn	Safety pin	2	2
14	2010000438	G05001A01000-004	Chain pin	1	-
14	2010000439	G05002A01000-004	Chain pin	-	1
15	2020001201	G05001A01400-000	Floating plate weldment	2	2
16	3040300084	GB/T5782-M22×120-8.8-EP•Zn	Hexagon head bolts	2	2
17	2010000437	G05001A01000-003	Hitch pin-Lower	2	2
18	3080100011	GB/T95-20-EP•Zn	Plain washer	3	3
19	3051000005	M20x1.5(OW-GUK20)	Round Lock net	3	3
20	2090000504	G05001A21000-000	Wheel fork assembly	2	2
21	2090000497	G05001A03000-000	Roller assembly	1	-

POS.	COD.	Specification	Description	60 /Qty	72 /Qty
21	2090000498	G05002A03000-000	Roller assembly	-	1
22	2090000501	G05001A26000-000	Bearing assembly	3	3
23	2090000499	G05001A02000-000	Cutter assembly	3	-
23	2090000500	G05002A02000-000	Cutter assembly	-	3
24	2090000503	G05001A07000-000	Gearbox assembly	1	1
25	3160400003	SPB132-1-2-22-HT200-O	Pulley	1	1
26	3120100067	GB/T91-3×20	Split pin	2	3

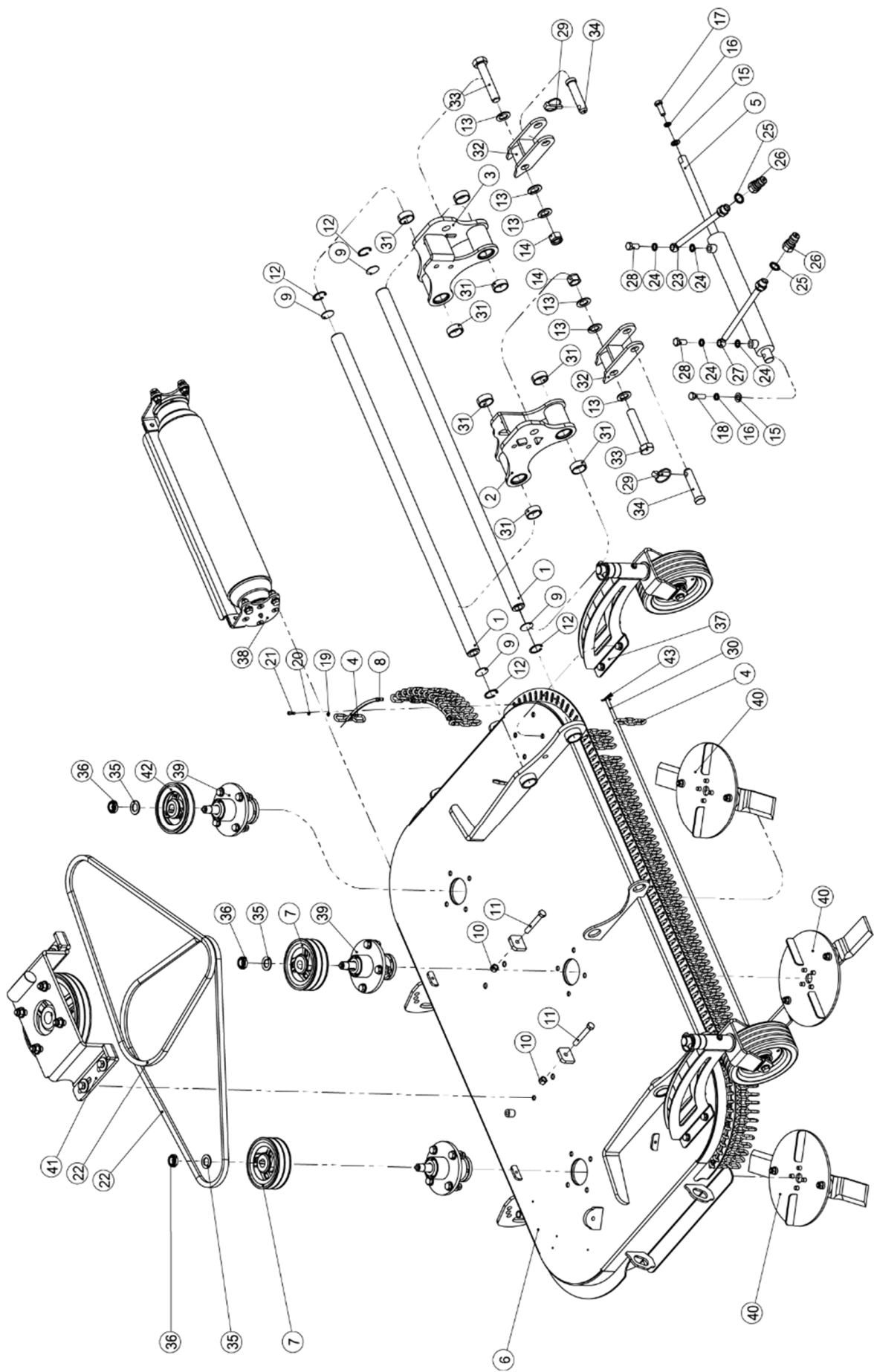

Hood component (ME-RC60H/ME-RC72H) parts name list:

POS.	COD.	Specification	Description	60H /Qty	72H /Qty
1	3230100009	MT90003	Guide rail	2	2
2	2020001197	G05001A01200-000	Left guide seat weldment	1	1
3	2020001198	G05001A01300-000	Right guide seat weldment	1	1
4	3130100014	6×28×20-3	Galvanized chain	78	90
5	3181300037	CDL1MP5-40/22/275-D-G1/4-	Hydraulic cylinder	1	1
6	2020001938	G05001A01100-000	Hood weldment	1	-
6	2020001939	G05002A01100-000	Hood weldment	-	1
7	3160400004	SPB132-2-2-22-HT200-O	Pulley	2	2
8	2000000590	G05001A01000-001	Chain fixing plate	4	4
9	2000000356	G01018A13000-001	End cover	4	4
10	3050100007	GB/T41-M12-5-EP•Zn	Hexagon nuts	2	2
11	3040100079	GB/T5783-M12×80-8.8-EP•Zn	Full-thread hexagon bolts	2	2
12	3080600023	GB/T893-35-A	Retaining rings for borP	4	4
13	3080100012	GB/T95-22-EP•Zn	Plain washer	6	6
14	3050500012	GB/T889.1-M22-8-EP•Zn	Locknut	2	2
15	3080100007	GB/T95-12-EP•Zn	Plain washer	2	2
16	3080500009	GB/T93-12-EP•Zn	Spring washer	2	2
17	3040100069	GB/T5783-M12×35-8.8-EP•Zn	Full-thread hex. bolts	1	1
18	3040100071	GB/T5783-M12×40-8.8-EP•Zn	Full-thread hex. bolts	1	1
19	3080100002	GB/T95-5-EP•Zn	Plain washer	8	8
20	3080500005	GB/T93-5-EP•Zn	Spring washer	8	8
21	3060100004	GB/T70.1-M5×16-8.8-EP•Zn	Hex. socket head screws	8	8
22	3160300001	GATES-XPB1800	Belt	2	-
22	3160300003	GATES-XPB1965	Belt	-	2
23	3180200149	1SN08BL×O20310-05-04/M10610-05-08×1900-04	Hose	1	1

POS.	COD.	Specification	Description	60H /Qty	72H /Qty
24	3170300001	BS/A-13.7×20.6×2-Q235	Combined sealing gaskets	4	4
25	3170300006	BS/A-21.5×28.6×2.5-Q235	Combined sealing gaskets	2	2
26	3180500001	Q00211041A-08-08	Hollow bolt	2	2
27	3180200039	1SN08BL×O20310-05-04/M10610-05-08×1500-04	Hose	1	1
28	3180300009	G1/4-28.5-6-22	Hollow bolt	2	2
29	3120400007	GB/T4329-12-EP•Zn	Safety pin	2	2
30	2010000438	G05001A01000-004	Chain pin	1	-
30	2010000439	G05002A01000-004	Chain pin	-	1
31	3101100001	36×42×15-POM	Guide ring	8	8
32	2020001201	G05001A01400-000	Floating plate weldment	2	2
33	3040300084	GB/T5782-M22×120-8.8-EP•Zn	Hexagon head bolts	2	2
34	2010000437	G05001A01000-003	Hitch pin-Lower	2	2
35	3080100011	GB/T95-20-EP•Zn	Plain washer	3	3
36	3051000005	M20x1.5(OW-GUK20)	Round Lock net	3	3
37	2090000504	G05001A21000-000	Wheel fork assembly	2	2
38	2090000497	G05001A03000-000	Roller assembly	1	-
38	2090000498	G05002A03000-000	Roller assembly	-	1
39	2090000501	G05001A26000-000	Bearing assembly	3	3
40	2090000499	G05001A02000-000	Cutter assembly	3	-
40	2090000500	G05002A02000-000	Cutter assembly	-	3
41	2090000503	G05001A07000-000	Gearbox assembly	1	1
42	3160400003	SPB132-1-2-22-HT200-O	Pulley	1	1
43	3120100067	GB/T91-3×20	Split pin	2	2

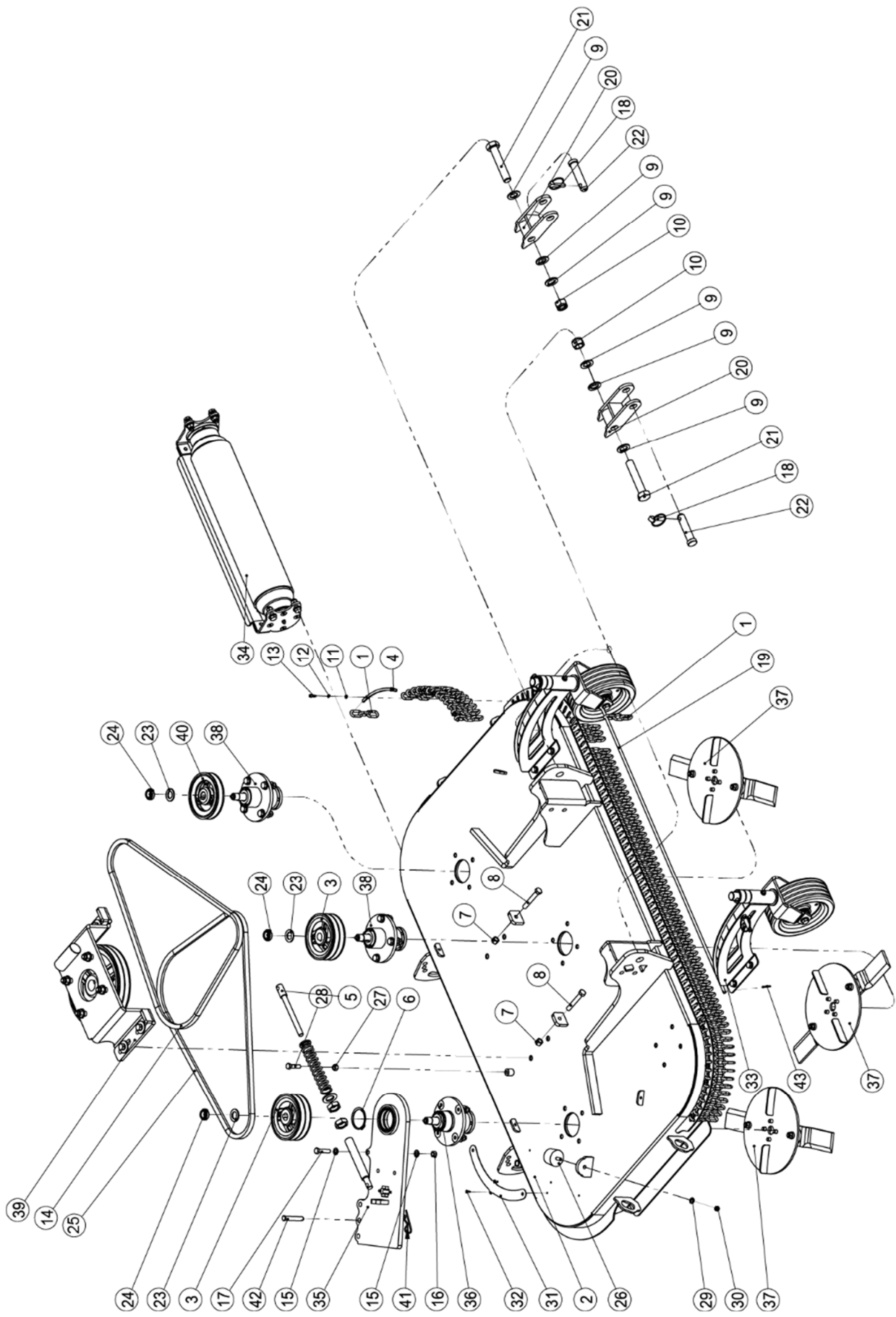

Hood component (**GME-RC60-DISC/ME-RC72-DISC**) parts name list:

POS.	COD.	Specification	Description	60-DISC /Qty	72-DISC /Qty
1	3130100014	6×28×20-3	Galvanized chain	78	90
2	2020001193	G05003A01100-000	Hood weldment	1	-
2	2020001194	G05004A01100-000	Hood weldment	-	1
3	3160400004	SPB132-2-2-22-HT200-O	Pulley	2	2
4	2000000590	G05001A01000-001	Chain fixing plate	4	4
5	2090001600	G05001A01500-000	Sliding rod assembly	1	1
6	3080700034	GB/T894-60-A	Retaining rings for shaft	1	1
7	3050100007	GB/T41-M12-5-EP•Zn	Hexagon nuts	2	2
8	3040100079	GB/T5783-M12×80-8.8-EP•Zn	Full-thread hex. bolts	2	2
9	3080100012	GB/T95-22-EP•Zn	Plain washer	6	6
10	3050500012	GB/T889.1-M22-8-EP•Zn	Locknut	2	2
11	3080100002	GB/T95-5-EP•Zn	Plain washer	8	8
12	3080500005	GB/T93-5-EP•Zn	Spring washer	8	8
13	3060100004	GB/T70.1-M5×16-8.8-EP•Zn	Hex. socket cap screws	8	8
14	3160300001	GATES-XPB1800	Belt	2	-
15	3080100006	GB/T95-10-EP•Zn	Plain washer	2	2
16	3050500004	GB/T889.1-M10-8-EP•Zn	Locknut	1	1
17	3040100048	GB/T5783-M10×45-8.8-EP•Zn	Full-thread hex. bolts	1	1
18	3120400007	GB/T4329-12-EP•Zn	Safety pin	2	2
19	2010000438	G05001A01000-004	Chain pin	1	-
19	2010000439	G05002A01000-004	Chain pin	-	1
20	2020001201	G05001A01400-000	Floating plate weldment	2	2
21	3040300084	GB/T5782-M22×120-8.8	Hex. head bolts	2	2
22	2010000437	G05001A01000-003	Hitch pin-Lower	2	2
23	3080100011	GB/T95-20-EP•Zn	Plain washer	3	3
24	3051000005	M20x1.5(OW-GUK20)	Round Lock net	3	3
25	3160300003	GATES-XPB1965	Belt	-	2

POS.	COD.	Specification	Description	60-DISC /Qty	72-DISC /Qty
26	3210200005	R04001A02000-004	Pipe Plug	1	1
27	3050100005	GB/T41-M10-5-EP•Zn	Hexagon nuts	1	1
28	3040100047	GB/T5783-M10×40-8.8-EP•Zn	Full-thread hex. bolts	1	1
29	3080100004	GB/T95-8-EP•Zn	Plain washer	1	1
30	3050500003	GB/T889.1-M8-8-EP•Zn	Locknut	1	1
31	2000000592	G05001A01000-002	Raceway board	1	1
32	3070100005	GB/T12618.4-4×10	Open end Oind rivets	4	4
33	2090000504	G05001A21000-000	Wheel fork assembly	2	2
34	2090000497	G05001A03000-000	Roller assembly	1	-
34	2090000498	G05002A03000-000	Roller assembly	-	1
35	2090001530	G05001A19000-000	Arm board assembly	1	1
36	2090000502	G05001A25000-000	Joint bearing assembly	1	1
37	2090000499	G05001A02000-000	Cutter assembly	3	-
37	2090000500	G05002A02000-000	Cutter assembly	-	3
38	2090000501	G05001A26000-000	Bearing assembly	2	2
39	2090000503	G05001A07000-000	Gearbox assembly	1	1
40	3160400003	SPB132-1-2-22-HT200-O	Pulley	1	1
41	3120400008	Din11024-4-EP•Zn	R Pin	1	1
42	3120200013	GB_T882-12×70-B-N	Parallel pin	1	1
43	3120100067	GB/T91-3×20	Split pin	2	2

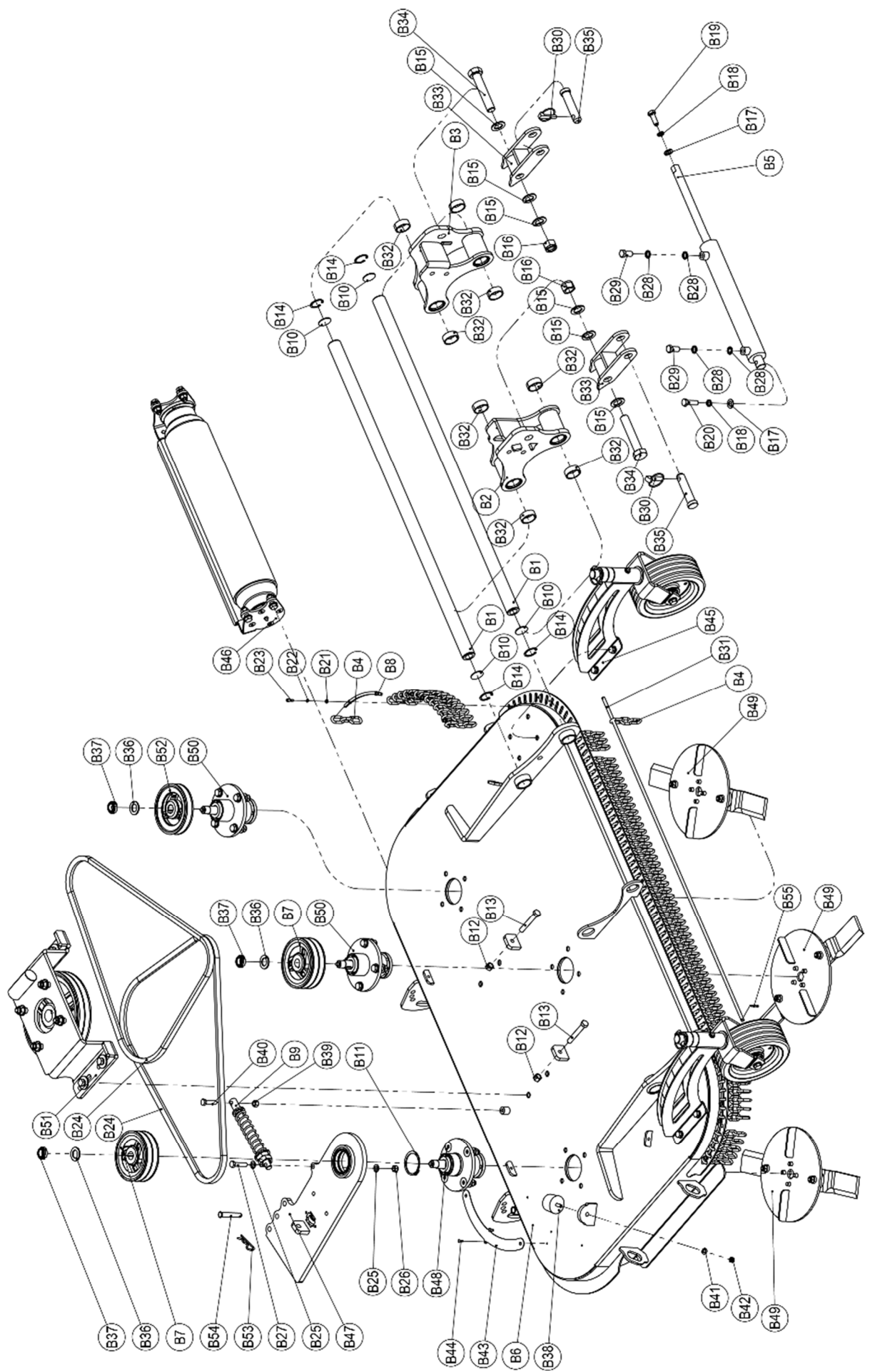

Hood component (ME-RC60H-DISC/ME-RC72H-DISC) parts name list:

POS.	COD.	Specification	Description	60H-DISC /Qty	72H-DISC /Qty
B1	3230100009	MT90003	Guide rail	2	2
B2	2020001197	G05001A01200-000	Left guide seat weldment	1	1
B3	2020001198	G05001A01300-000	Right guide seat weldment	1	1
B4	3130100014	6×28×20-3	Galvanized chain	78	90
B5	3181300037	CDL1MP5-40/22/275-D-G1/4-2CAUM	Hydraulic cylinder	1	1
B6	2020001938	G05001A01100-000	Hood weldment	1	-
B6	2020001939	G05002A01100-000	Hood weldment	-	1
B7	3160400004	SPB132-2-2-22-HT200-O	Pulley	2	2
B8	2000000590	G05001A01000-001	Chain fixing plate	4	4
B9	2090001600	G05001A01500-000	Sliding Rod Assembly	1	1
B10	2000000356	G01018A13000-001	End cover	4	4
B11	3080700034	GB/T894-60-A	Retaining rings for shaft	1	1
B12	3050100007	GB/T41-M12-5-EP•Zn	Hexagon nuts	2	2
B13	3040100079	GB/T5783-M12×80-8.8	Full-thread hexagon bolts	2	2
B14	3080600023	GB/T893-35-A	Retaining rings for borP	4	4
B15	3080100012	GB/T95-22-EP•Zn	Plain washer	6	6
B16	3050500012	GB/T889.1-M22-8-EP•Zn	Locknut	2	2
B17	3080100007	GB/T95-12-EP•Zn	Plain washer	2	2
B18	3080500009	GB/T93-12-EP•Zn	Spring washer	2	2
B19	3040100069	GB/T5783-M12×35-8.8	Full-thread hexagon bolts	1	1
B20	3040100071	GB/T5783-M12×40-8.8	Full-thread hexagon bolts	1	1
B21	3080100002	GB/T95-5-EP•Zn	Plain washer	8	8
B22	3080500005	GB/T93-5-EP•Zn	Spring washer	8	8
B23	3060100004	GB/T70.1-M5×16-8.8	Hex. socket head cap screws	8	8
B24	3160300001	GATES-XPB1800	Belt	2	-
B24	3160300003	GATES-XPB1965	Belt	-	2
B25	3080100006	GB/T95-10-EP•Zn	Plain washer	2	2
B26	3050500004	GB/T889.1-M10-8-EP•Zn	Locknut	1	1
B27	3040100718	GB/T5783-M10×45-10.9-O	Full-thread hex. bolts	1	1
B28	3170300001	BS/A-13.7×20.6×2-Q235	Combined sealing gaskets	4	4
B29	3180300009	G1/4-28.5-6-22	Hollow bolt	2	2

POS.	COD.	Specification	Description	60H-DISC /Qty	72H-DISC /Qty
B30	3120400007	GB/T4329-12-EP•Zn	Safety pin	2	2
B31	2010000438	G05001A01000-004	Chain pin	1	-
B31	2010000439	G05002A01000-004	Chain pin	-	1
B32	3101100001	36×42×15-POM	Guide ring	8	8
B33	2020001201	G05001A01400-000	Floating plate weldment	2	2
B34	3040300084	GB/T5782-M22×120-8.8	Hexagon head bolts	2	2
B35	2010000437	G05001A01000-003	Hitch pin-Lower	2	2
B36	3080100011	GB/T95-20-EP•Zn	Plain washer	3	3
B37	3051000005	M20x1.5(OW-GUK20)	Round lock nut	3	3
B38	3210200005	R04001A02000-004	Pipe plug	1	1
B39	3050100005	GB/T41-M10-5-EP•Zn	Hexagon nuts	1	1
B40	3040100047	GB/T5783-M10×40-8.8	Full-thread hex. bolts	1	1
B41	3080100004	GB/T95-8-EP•Zn	Plain washer	1	1
B42	3050500003	GB/T889.1-M8-8-EP•Zn	Locknut	1	1
B43	2000000592	G05001A01000-002	Raceway board	1	1
B44	3070100005	GB/T12618.4-4×10	Open end Oind rivets	4	4
B45	2090000504	G05001A21000-000	Wheel fork assembly	2	2
B46	2090000497	G05001A03000-000	Roller assembly	1	-
B46	2090000498	G05002A03000-000	Roller assembly	-	1
B47	2090001530	G05001A19000-000	Arm board assembly	1	1
B48	2090000502	G05001A25000-000	Joint bearing assembly	1	1
B49	2090000499	G05001A02000-000	Cutter assembly	3	-
B49	2090000500	G05002A02000-000	Cutter assembly	-	3
B50	2090000501	G05001A26000-000	Bearing assembly	2	2
B51	2090000503	G05001A07000-000	Gearbox assembly	1	1
B52	3160400003	SPB132-1-2-22-HT200-O	Pulley	1	1
B53	3120400008	Din11024-4-EP•Zn	R Pin	1	1
B54	3120200013	GB_T882-12×70-B-N	Parallel pin	1	1
B55	3120100067	GB/T91-3×20	Split pin	2	2

BLADE AXLE ASSEMBLY

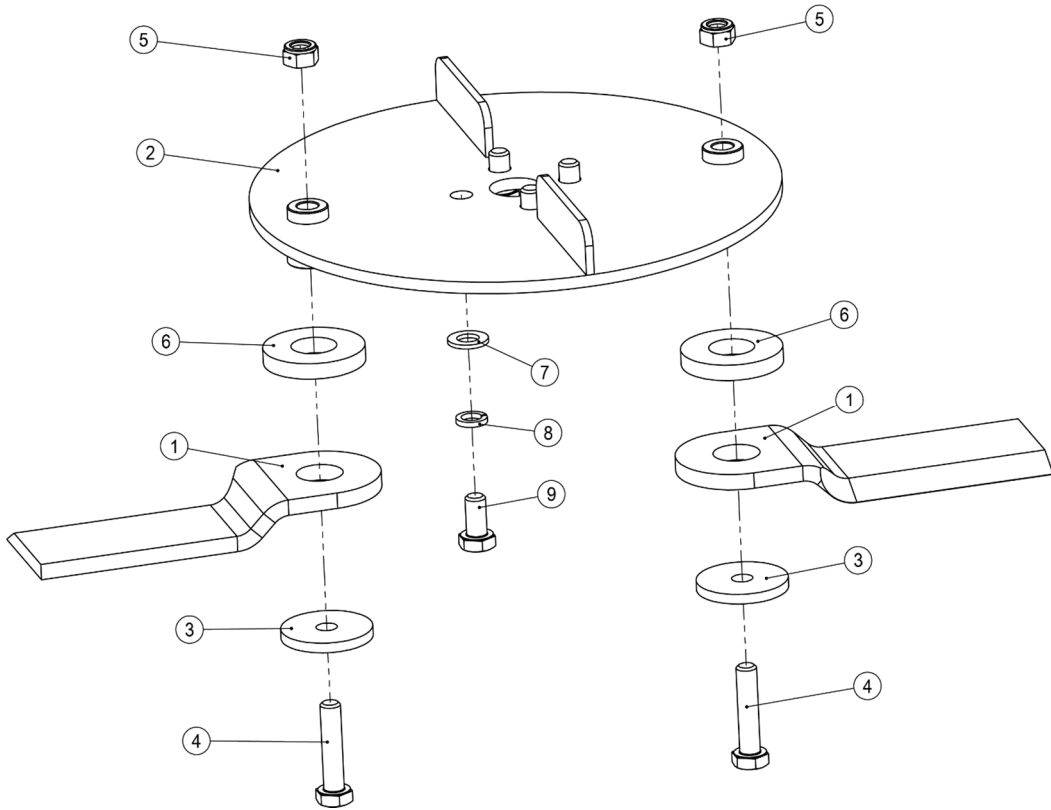

Blade axle assemble parts name list:

POS.	COD.	Specification	Description	60(H-DISC) /Qty	72(HDISC) /Qty
1	3220100033	MT03001	Blade	2	2
2	2020001202	G05001A02100-000	Cutter weldment	1	-
2	2020001203	G05002A02100-000	Cutter weldment	-	1
3	2000000125	G05001A25000-007	fixed washer	2	2
4	3040100718	GB/T5783-M10×45- 10.9-O	Full-thread hex. bolts	2	2
5	3050500004	GB/T889.1-M10-8-EP•Zn	Locknut	2	2
6	2000000591	G05001A02000-001	Blade spacer	2	2
7	3080100006	GB/T95-10-EP•Zn	Plain washer	4	4
8	3080500008	GB/T93-10-EP•Zn	Spring washer	4	4
9	3040100041	GB/T5783-M10×20- 8.8-EP•Zn	Full-thread hex. bolts	4	4

WHEEL COMPONENT

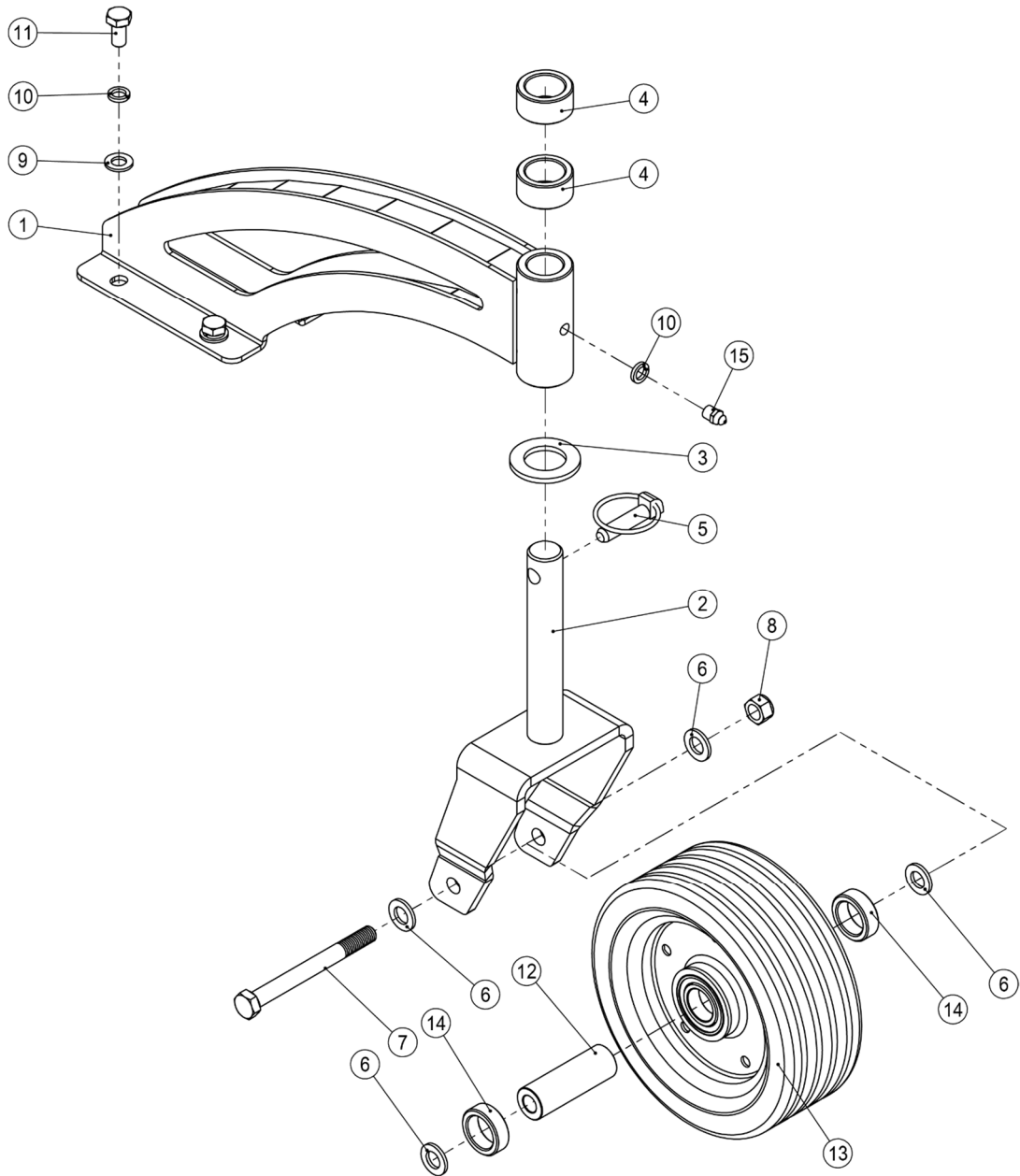

Wheel component parts name list:

POS.	COD.	Specification	Description	Qty
1	2020001220	G05001A21100-000	Swivel fork support weldment	1
2	2020001007	R04001A04100-000	Fork welded joint	1
3	3080100014	GB/T95-27-EP•Zn	Plain washer	1
4	2010000440	R04001A04000-001	Spacer	2
5	3120400007	GB/T4329-12-EP•Zn	Safety pin	1
6	3080100007	GB/T95-12-EP•Zn	Plain washer	4
7	3040300036	GB/T5782-M12×120- 8.8-EP•Zn	Hex. head bolts	1
8	3050500007	GB/T889.1-M12-8-EP•Zn	Locknut	1
9	3080100006	GB/T95-10-EP•Zn	Plain washer	4
10	3080500008	GB/T93-10-EP•Zn	Spring washer	5
11	3040100041	GB/T5783-M10×20- 8.8-EP•Zn	Full-thread hex. bolts	4
12	2010000115	R04001A04000-002	Wheel axle	1
13	3140200631	200-78-25-FM	Wheel	1
14	3210500007	R04001A04000-003	Rubber	2
15	3170400005	DIN71412-A G1/8 304	Grease nipple	1

GEAR BOX ASSEMBLY

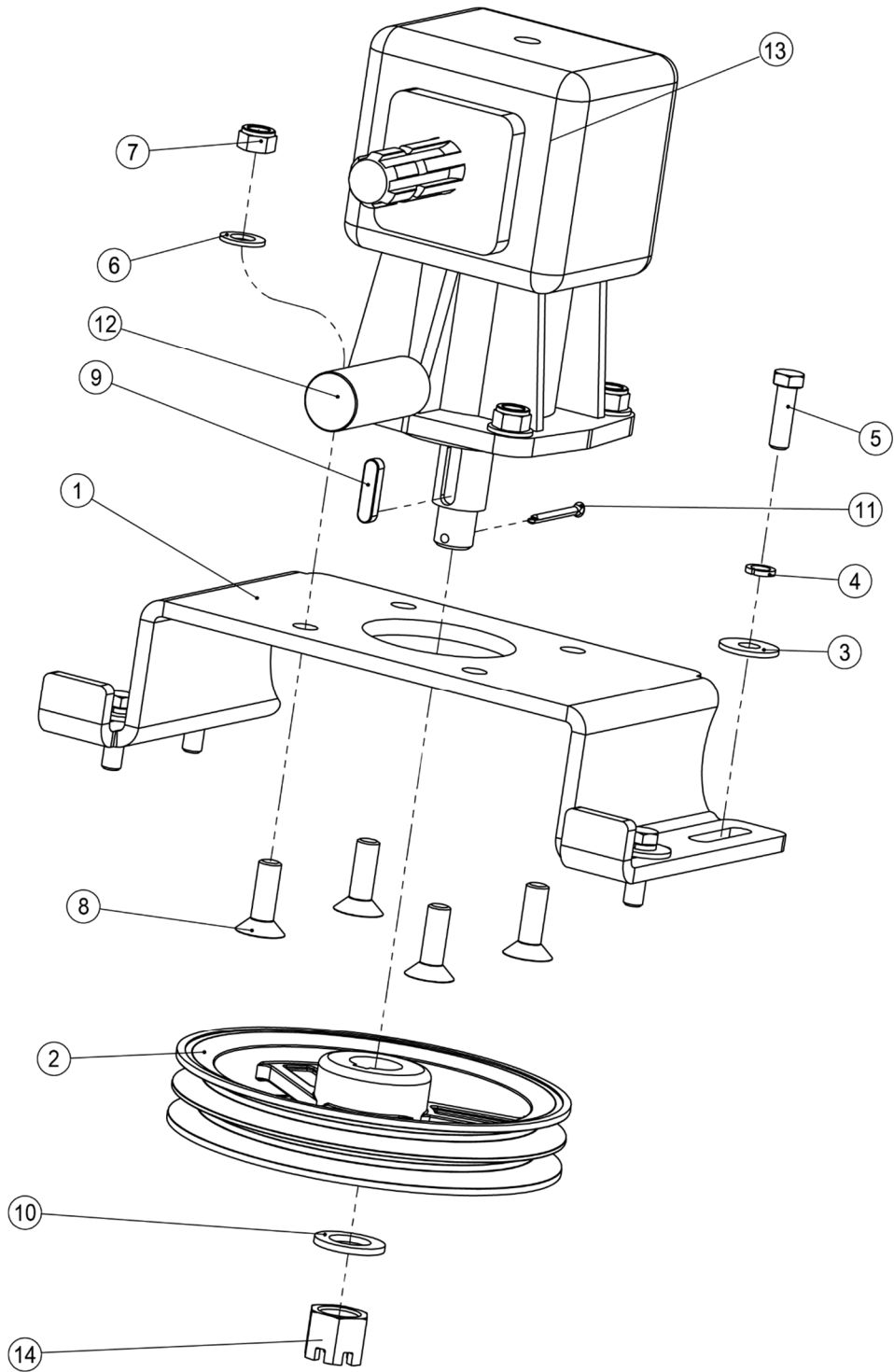

Gear box assembly parts name list:

POS.	COD.	Specification	Description	Qty
1	200000586	G05001A07000-001	Mounting seat	1
2	3160400005	SPB238-2-2-33-HT200- O	Pulley	1
3	3080200010	GB/T96.2-12-EP•Zn	Large plain washer	4
4	3080500009	GB/T93-12-EP•Zn	Spring washer	4
5	3040100071	GB/T5783-M12×40-8.8-EP•Zn	Full-thread hexagon bolts	4
6	3080100008	GB/T95-14-EP•Zn	Plain washer	4
7	3050500008	GB/T889.1-M14-8-EP•Zn	Locknut	4
8	3060200063	GB/T70.3-M14×45-8.8-EP•Zn	HSCS-Countersunk	4
9	3090100009	GB/T1096-A10×8×40-EP•Zn	Square and rectangular keys	1
10	3080100013	GB/T95-24-EP•Zn	Plain washer	1
11	3120100109	GB/T91-5×50	Split pin	1
12	3210500603	Φ35×90	Rubber	1
13	3160100707	KF030R283Z0100	Gear box	1
14	3050800012	GB/T9459-M24×2-05-EP•Zn•P	Hex. slotted and castle nuts	1

Parts name list:

POS.	COD.	Specification	Description	60(H-DISC) /Qty	72(H-DISC) /Qty
1	2020001213	G05001A03100-000	Roller weldment	1	-
	2020001214	G05002A03100-000	Roller weldment	-	1
2	2000000587	G05001A03000-002	Roller connecting plate A	1	1
3	2000000595	G05001A03000-003	Roller connecting plate B	1	1
4	3150100006	F01001A03200-001	Bearing seat	2	2
5	3080100007	GB/T95-12-EP•Zn	Plain washer	8	8
6	3050500007	GB/T889.1-M12-8-EP•Zn	Locknut	4	4
7	3040100069	GB/T5783-M12×35- 8.8-EP•Zn	Full-thread hex. bolts	4	4
8	3170400005	DIN71412-A G1/8 304	Grease nipple	2	2
9	3100200007	GB/T281-1305	Self-aligning ball bearing	2	2
10	3170100018	GB/T13871.1-FB- 40×62×8-NBR	Shaft seal	2	2
11	3060200018	GB/T70.3-M8×20-8.8-EP•Zn	HSCS-Countersunk	8	8
12	3080600038	GB/T893-62-A	Circlips for holes	2	2
13	2000000593	G05001A03000-001	Scraper	1	-
	2000000594	G05002A03000-001	Scraper	-	1
	20000005071	G05009A03000-001	Scraper	-	-
14	3080100006	GB/T95-10-EP•Zn	Plain washer	2	2
15	3080500008	GB/T93-10-EP•Zn	Spring washer	2	2
16	3040100041	GB/T5783-M10×20- 8.8-EP•Zn	Full-thread hex. bolts	2	2

COVER ASSEMBLY

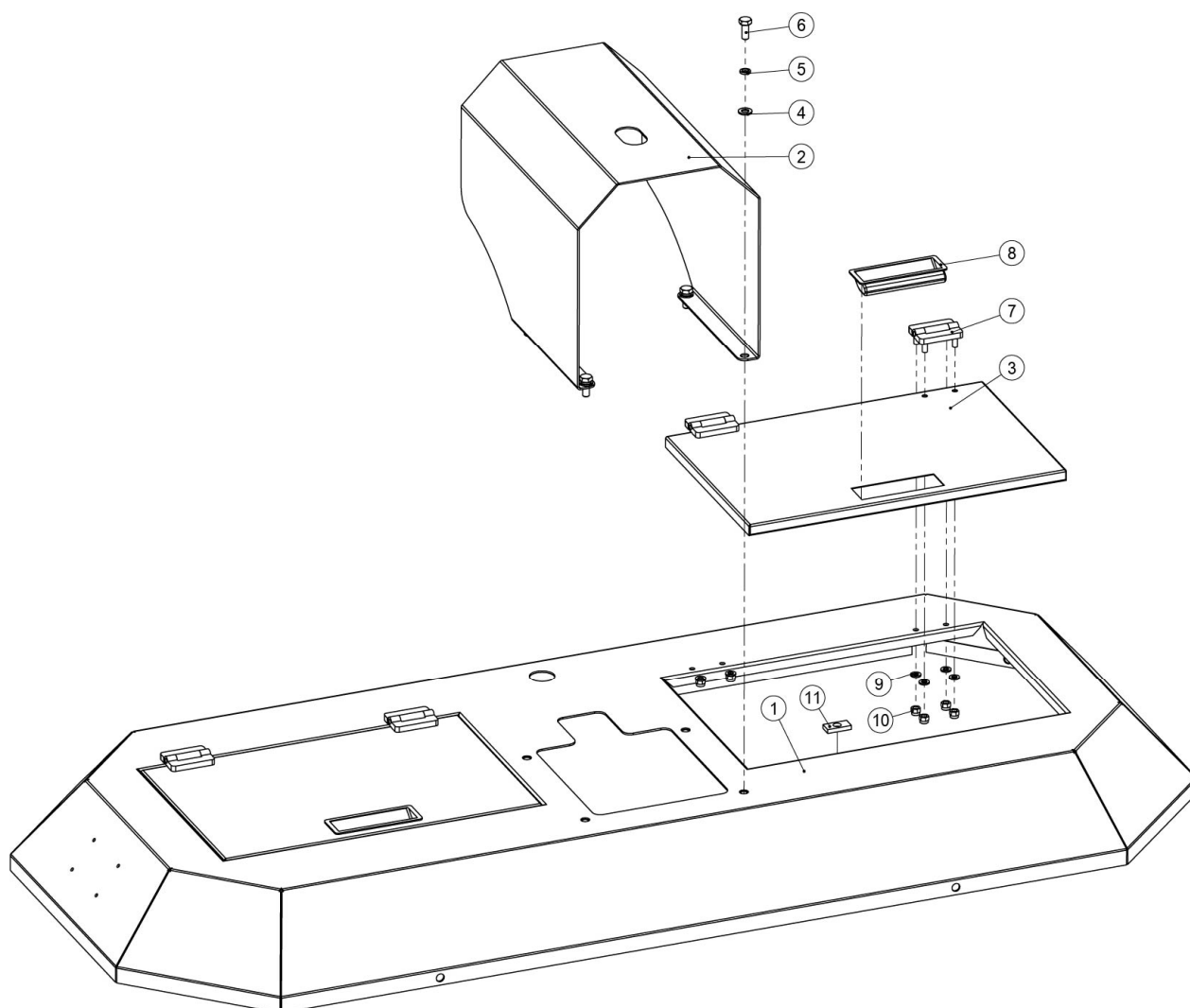

Parts name list:

POS.	COD.	Specification	Description	60(H-DISC) /Qty	72(H-DISC) /Qty
1	2020001207	G05005A11100-000	Cover base weldment	1	-
1	2020001208	G05006A11100-000	Cover base weldment	-	1
2	2000000589	G05001A11000-001	PTO cover	1	1
3	2000000588	G05001A11000-002	Gate cover	2	2
4	3080100004	GB/T95-8-EP•Zn	Plain washer	4	4
5	3080500007	GB/T93-8-EP•Zn	Spring washer	4	4
6	3040100022	GB/T5783-M8×20-8.8	Full-thread hexagon bolts	4	4

POS.	COD.	Specification	Description	60(H-DISC) /Qty	72(H-DISC) /Qty
7	3140500004	54x40xM6	Zinc alloy die-casting hinge	4	4
8	3140100001	102x34	Pull handle	2	2
9	3080100003	GB/T95-6-EP•Zn	Plain washer	16	16
10	3050500002	GB/T889.1-M6-8-EP•Zn	Locknut	16	16
11	3140300001	30x15x5	Magnet	4	4

JOINT BEARING ASSEMBLY

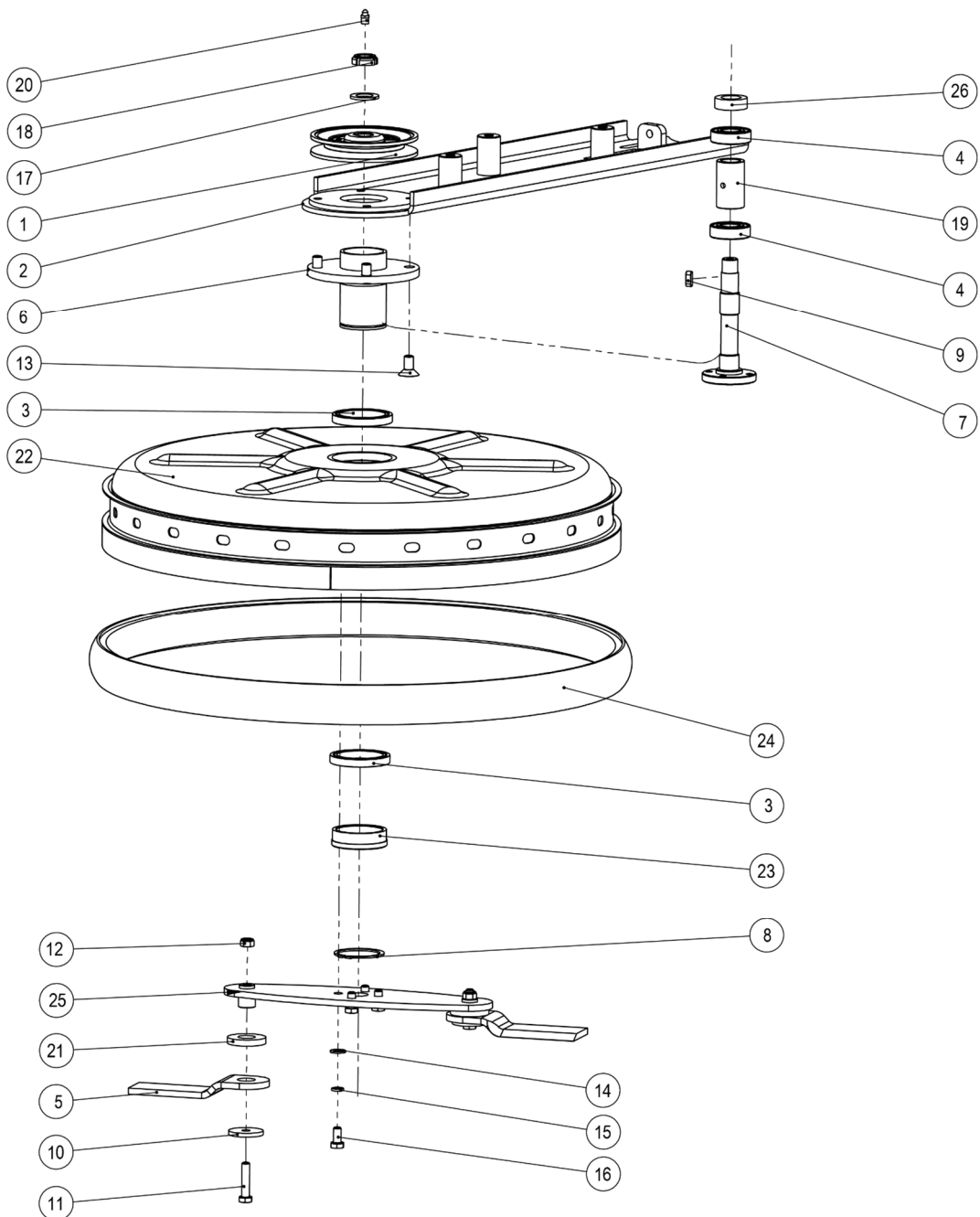

POS	COD.	Specification	Description	60(H-DISC) /Qty	72 (H-DISC) /Qty
1	3160400003	SPB132-1-2-22-HT200-O	Pulley	1	1
2	2020001921	G05001A25200-000	Arm board weldment	1	-
	2020001942	G05002A25200-000	Arm board weldment	-	1
3	3100100621	GB_T276-61812-RZ	Deep groove ball bearing	2	2
4	3100100032	GB_T276-6205-2RZ	Deep groove ball bearing	2	2
5	3220100033	MT03001	Blade	2	2
6	2020001204	G05001A25300-000	Floating bearing seat	1	1
7	3150200028	G05001A25000-003	Axle	1	1
8	3080700034	GB/T894-60-A	Circlips for shaft	1	1
9	3090100004	GB/T1096-A8×7×20-EP•Zn	Square and rectangular keys	1	1
10	2000000125	G05001A25000-007	fixed washer	2	2
11	3040100718	GB/T5783-M10×45-10.9-O	Full-thread hexagon bolts	2	2
12	3050500004	GB/T889.1-M10-8-EP•Zn	Locknut	2	2
13	3060200047	GB/T70.3-M12×25-8.8	HSCS-Countersunk	4	4
14	3080100006	GB/T95-10-EP•Zn	Plain washer	4	4
15	3080500008	GB/T93-10-EP•Zn	Spring washer	4	4
16	3040100041	GB/T5783-M10×20-8.8	Full-thread hexagon bolts	4	4
17	3080100011	GB/T95-20-EP•Zn	Plain washer	1	1
18	3051000005	M20x1.5(OW-GUK20)	Round Lock net	1	1
19	2010000435	G05001A25000-002	Spacer	1	1
20	3170400005	DIN71412-A G1/8 304	Grease nipple	1	1
21	2000000591	G05001A02000-001	Blade spacer	2	2
22	2020001943	G05001A25400-000	Floating cutter head cover	1	1
23	2010000769	G05001A25000-004	Fixed sleeve	1	1
24	3210500047	G01001A30100-001	Rubber ring	1	1
25	2020001222	G05001A02200-000	Floating cutter weldment	1	1
26	2010000436	G05001A25000-001	Pulley spacer	1	1

SLIDING ROD ASSEMBLY

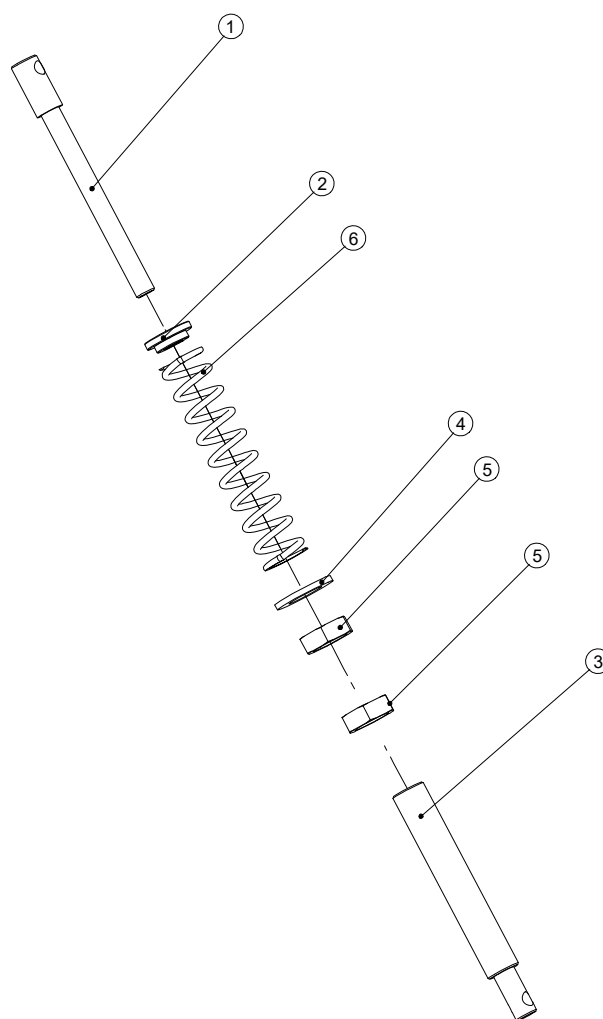

Parts name list:

POS.	COD.	Specification	Description	Qty
1	2010000697	G05001A01500-002	Sliding rod	
2	2010000699	G05001A01500-003	Gasket	1
3	2010000698	G05001A01500-001	Guide rod	1
4	3080100013	GB/T95-24-EP•Zn	Plain washer	1
5	3050300010	GB/T6172.1-M24-04-EP•Zn	Hexagon thin nut	2
6	3110200036	RY I -4.5×34×15×160×9-R-65Mn-EP•Zn	Spring	1

ARM BOARD ASSEMBLY

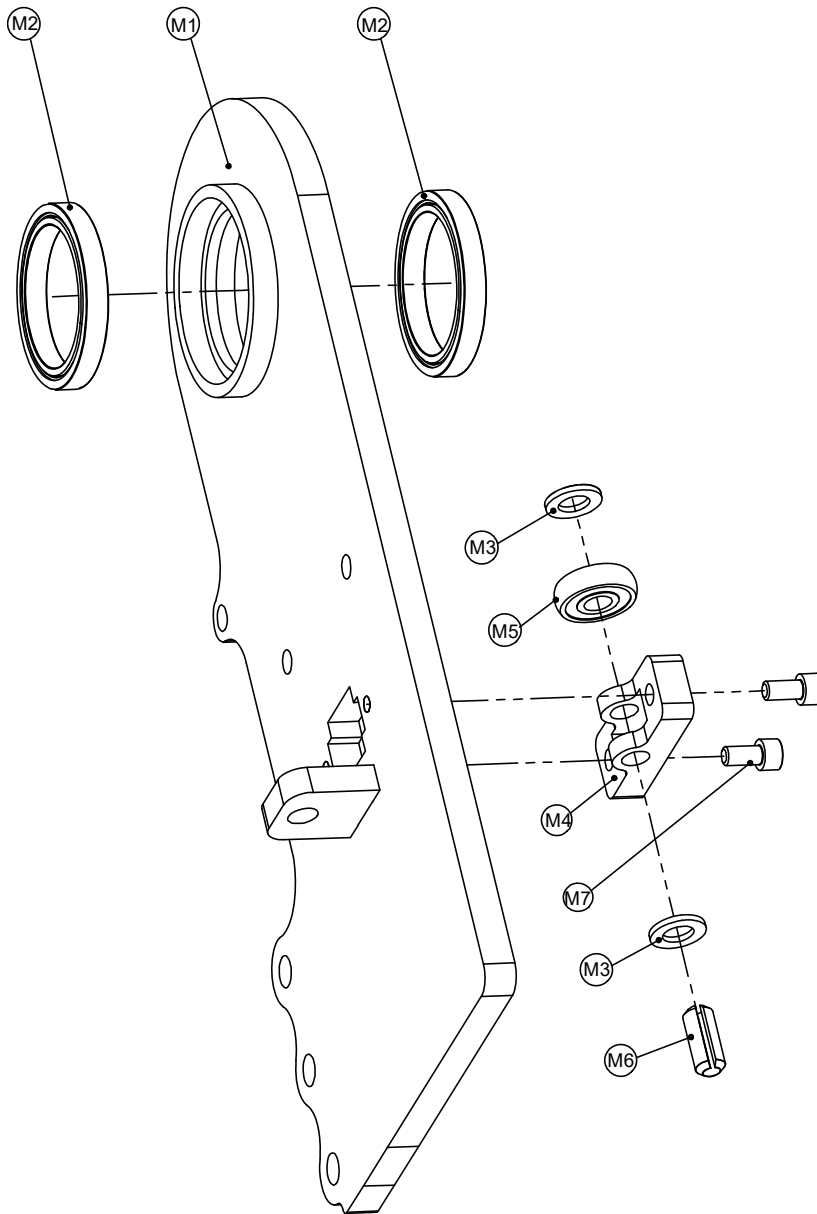

Parts name list:

POS.	COD.	Specification	Description	Qty
M1	2020001937	G05001A19100-000	Arm bearing seat weldment	1
M2	3100100060	UBC-61812-2RS	Deep groove ball bearing	2
M3	3080100007	GB/T95-12-EP•Zn	Plain washer	2
M4	3150100023	G05001A19000-001	Bearing seat	1
M5	3100600001	SC6201-RS	Insert bearing	1
M6	3120300037	GB_T879.1-12×30-St-N	Spring-type straight pin	1
M7	3060100025	GB/T70.1-M8×16-8.8-EP•Zn	Hex. socket head cap screws	2

JOINT BEARING ASSEMBLY

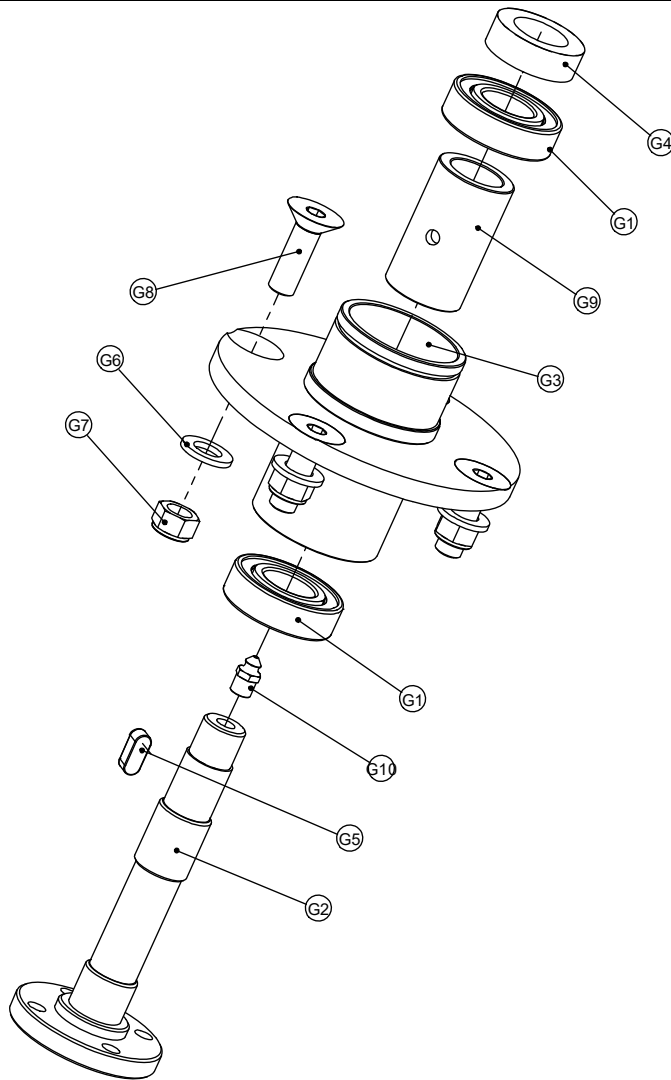

POS.	COD.	Specification	Description	Qty
G1	3100100032	GB_T276-6205-2RZ	Deep groove ball bearing	2
G2	3150200028	G05001A25000-003	Axle	1
G3	2020001219	G05001A25100-000	Joint bearing seat weldment	1
G4	2010000436	G05001A25000-001	Pulley spacer	1
G5	3090100004	GB/T1096-A8×7×20-EP•Zn	Square and rectangular keys	1
G6	3080100007	GB/T95-12-EP•Zn	Plain washer	4
G7	3050500007	GB/T889.1-M12-8-EP•Zn	Locknut	4
G8	3060200050	GB/T70.3-M12×40-8.8	HSCS-Countersunk	4
G9	2010000435	G05001A25000-002	Spacer	1
G10	3170400005	DIN71412-A G1/8 304	Grease nipple	1

BEARING ASSEMBLY

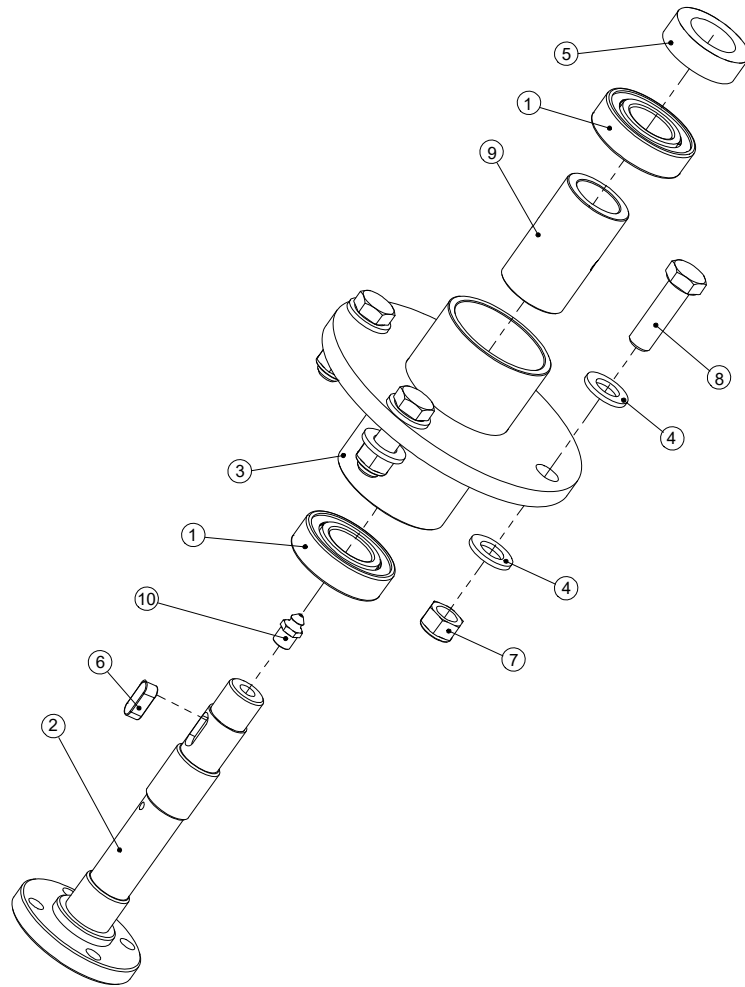

POS.	COD.	Specification	Description	Qty
1	3100100032	GB_T276-6205-2RZ	Deep groove ball bearing	2
2	3150200028	G05001A25000-003	Axle	1
3	2020000201	G05001A26100-000	Bearing weldment	1
4	3080100007	GB/T95-12-EP•Zn	Plain washer	8
5	2010000436	G05001A25000-001	Pulley spacer	1
6	3090100004	GB/T1096-A8×7×20-EP•Zn	Square and rectangular keys	1
7	3050500007	GB/T889.1-M12-8-EP•Zn	Locknut	4
8	3040100071	GB/T5783-M12×40-8.8-EP•Zn	Full-thread hex. bolts	4
9	2010000435	G05001A25000-002	Spacer	1
10	3170400005	DIN71412-A G1/8 304	Grease nipple	1

