



Rotary Tiller

OPERATOR'S MANUAL

ME-RT36-M

ME-RT40-M

ME-RT48-M

ME-RT54-M

ME-RT60-M

ME-RT72-M

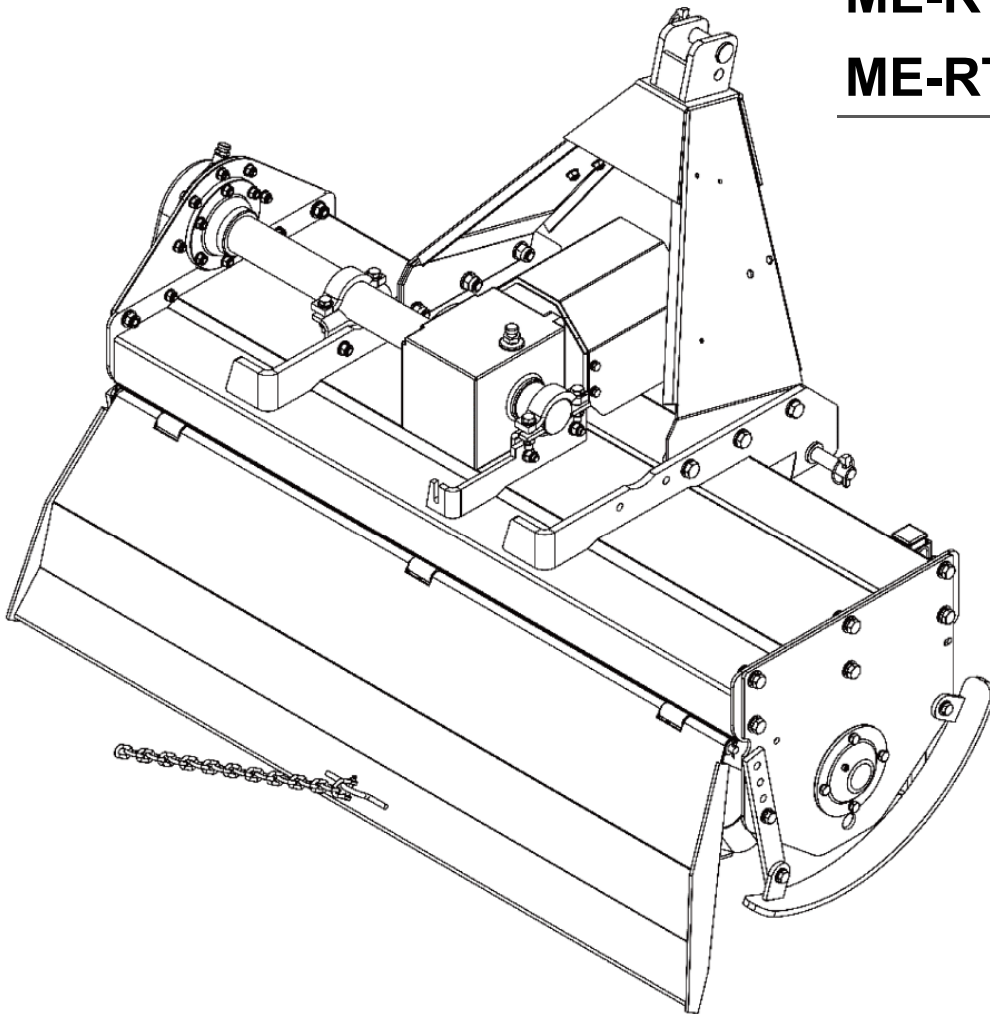

Please carefully read this manual and follow all the instructions. Failure to comply with the warnings and precautions may result in serious injury or death.

Content

CONTENT	1
SAFETY PRECAUTIONS.....	5
Safety First	5
Safety Alert Symbol	6
Safety for Children.....	6
Operation Safety	7
Tractor Shutdown Safety	7
Use A Safety Chain.....	7
Transport Safely	8
Avoid Crystalline Silica (Quartz) Dust	8
Avoid Contact Blades	9
Maintenance Safety	9
Preparation Before Maintenance	10
Personal Protective Equipment.....	10
Keep Riders Off Machinery.....	11
Safety Lights and Devices	11
Seat Belt and ROPS	11
Hydraulic System Safety.....	11
Handle Chemicals Properly	12
Tire Maintenance Safety	12
Storage and Disposal Safety	13

Storage Safety	13
Disposal Safety	13
Safety Labels	13
Labels Location	14
PRODUCT INTRODUCTION	15
Technical Data	17
Implement Identification	19
UNPACKING	20
ASSEMBLY & SET-UP	22
Installing Rear Deflector	22
Connecting Hitch to Tiller	23
Tractor Shutdown	23
Tractor Hook-up	24
Driveline Installation	25
Driveline Length Check	26
Maximum Extended Position	27
Customize Driveline	28
Driveline Interference Check	29
OPERATION	30
General Operating Instructions	30
Checklist before Operation	31
Levelling the Tiller	32
Adjusting Rear Deflector	32

Adjusting Park Stand.....	33
SERVICE AND MAINTENANCE	33
General Service.....	34
Gearbox Maintenance.....	34
PTO Shaft Maintenance	34
Lubrication Parts	35
Tightening Torque.....	37
Replacing the Blade.....	38
STORAGE AND TRANSPORT	39
Storage	39
Transport	40
TROUBLESHOOTING.....	41
EXPLODED VIEW AND PARTS LIST	44
WARRANTY.....	67

This page left blank intentionally!

SAFETY PRECAUTIONS

Listed below descriptions are common practices that may or may not be applicable to the products described in this manual.

Safety First

Careful operation is your best assurance against an accident.

Please be fully aware that you are responsible for the safe operation and maintenance of your implement. You must ensure that you and anyone else who is going to operate, maintain or work around the implement is familiar with the operating and maintenance procedures and related safe information contained in this manual. This manual is prepared to guide you through all essential operations related to this implement and alert you to all good safety practices that should be strictly followed.



Please constantly bear in mind that good safety practices not only protect you but also the people around you. Incorporate these practices an inseparable part into your safety program. Make sure that who operates this equipment is familiar with the recommended operating and maintenance procedures and follows all the safety precautions. Most accidents can be prevented. Do not risk injury of death by ignoring good safety practices.

- Thoroughly read and understand the “**Safety Labels**” section. Read all instructions noted on them.
- Do not operate the equipment while under the influence of drugs or alcohol, as they impair your ability to safely and properly operate the equipment.
- The operator should be familiar with all functions of the tractor and attached implement, and be able to handle emergencies quickly.
- Make sure all guards and shields appropriate for the operation are in place and secured before operating the implement.
- Keep all bystanders away from equipment and work area. Start tractor from the driver’s seat with hydraulic controls in neutral.
- Operate tractor and controls from the driver’s seat only.
- Never dismount from a moving tractor or leave tractor unattended with engine running.
- Do not allow anyone to stand between the implement and tractor while backing up to the implement.
- Keep hands, feet, and clothing away from power-driven parts.

- While transporting and operating equipment, watch out for objects overhead and along the sides such as fences, trees, buildings, wires, etc.
- Do not turn tractor so tight as to cause hitched implement to ride up on the tractor's rear wheel.
- Store implement in a safe and secure area where children normally do not play. When needed, secure implement against falling with support blocks.

Safety Alert Symbol

The SAFETY ALERT SYMBOL indicates there is a potential hazard to personal safety and extra precaution must be taken. When you see this symbol, be alert and carefully read the message that follows it. Hazard control, and accident prevention are dependent upon the awareness, concern, prudence, and proper training of personnel involved in the operation, transport, maintenance, and storage of equipment.

Be Aware of Signal Words

A signal word designates a degree or level of hazard seriousness. They are:

 **DANGER:** Indicates a hazardous situation that, if not avoided, will result in death or serious injury.

 **WARNING:** Indicates a hazardous situation that, if not avoided, could result in death or serious injury.

 **CAUTION:** Indicates a hazardous situation that, if not avoided, may result in minor or moderate injury.

Be Aware of Special Notices

Special notices are intended to point out important and helpful information that should be followed. They are:

ATTENTION: Indicates that equipment or property damage could result if instructions are not followed.

NOTE: Indicates supplementary explanations that will be helpful when using the equipment.

Safety for Children

Tragedy can occur if the operator is not alert to the presence of children, Children generally are attracted to implements and their work.

- Never assume children will remain where you last saw them.
- Keep children out of the work area and under the watchful eye of a responsible adult.

- Be alert and shut the implement and tractor down if children enter the work area.
- Never carry children on the tractor or implement. There is not a safe place for them to ride. They may fall off and be run over or interfere with the control of the power machine.
- Never allow children to operate the power machine, even under adult supervision.
- Never allow children to play on the power machine or implement.

Operation Safety

Use extra caution when backing up. Before the tractor starts to move, look down and behind to make sure the area is safety and clear.

Tractor Shutdown Safety

If engaged, disengage power take-off.

Park on solid, level ground and lower implement to ground or onto support blocks.

- Put tractor in park or set park brake.
- Turn off engine and remove ignition key to prevent unauthorized starting.
- Relieve all hydraulic pressure to auxiliary hydraulic lines.
- Wait for all components to stop before leaving operator's seat.
- Use steps, grab-handles and anti-slip surfaces when stepping on or off the tractor.
- If engaged, disengage power take-off.
- Park on solid, level ground and lower implement to ground or onto support blocks.
- Put tractor in park or set park brake.
- Turn off engine and remove ignition key to prevent unauthorized starting.
- Relieve all hydraulic pressure to auxiliary hydraulic lines.
- Wait for all components to stop before leaving operator's seat.
- Use steps, grab-handles and anti-slip surfaces when stepping on and off the tractor.

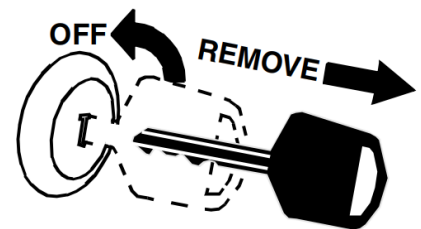

Use a Safety Chain

A safety chain will help control drawn machinery should it separate from the tractor drawbar.

Use a chain with the strength rating equal to or greater than the gross weight of the towed implement.

- Attach the chain to the tractor drawbar support or other specified anchor location. Allow only enough slack in the chain to permit turning.
- Always hitch the implement to the machine towing it. Do not use the safety chain to tow the



implement.

Transport Safely

- Comply with federal, state, and local laws.
- Avoid contact with any overhead utility lines or electrically charged conductors.
- Engage park brake when stopped on an incline.
- Maximum transport speed for an implement is 30 km/h.
DO NOT EXCEED.
- Never travel at a speed which does not allow adequate control of steering and stopping. Some rough terrains require a slower speed. Sudden braking can cause a towed load to swerve and upset.
- Do not tow an implement that, when fully loaded, weights more than 1.5 times the weight of towing vehicle.

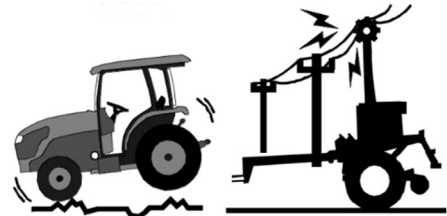

Avoid Crystalline Silica (Quartz) Dust

Because crystalline silica is a basic component of sand and granite, many activities at construction sites produce dust containing crystalline silica. Trenching, sawing, and boring of material containing crystalline silica can produce dust containing crystalline silica particles.

This dust can cause serious injury to the lungs (silicosis). There are guidelines which should be followed if crystalline silica (quartz) is present in the dust.

- Be aware of and follow OSHA (or other local, State, or Federal) guidelines for exposure to airborne crystalline silica.
- Know the work operations where exposure to crystalline silica may occur.
- Participate in air monitoring or training programs offered by the employer.
- Be aware of and use optional equipment controls such as water sprays, local exhaust ventilation, and enclosed cabs with positive pressure air conditioning if the machine has such equipment. Otherwise respirators shall be worn.
- Where respirators are required, wear a respirator approved for protection against crystalline silica containing dust. Do not alter respirator in any way. Workers who use tight-fitting respirators cannot have beards/ mustaches which interfere with the respirator seal to the face.
- If possible, change into disposable or washable work clothes at the work site; shower and change into clean clothing before leaving the work site.
- Do not eat, drink, use tobacco products, or apply cosmetics in areas where there is dust containing crystalline silica.



- Store food, drink, and personal belongings away from the work area.
- Wash hands and face before eating, drinking, smoking, or applying cosmetics after leaving the exposure area.

Avoid Contact Blades

Keep away from rotating blades to avoid death or serious injury from blade contact.

- Stay away and keep hands, feet and body away from rotating blades, drivelines and parts until all moving elements have stopped.
- Do not put hands or feet under implement hood.
- Stop rotating blades disengage PTO and wait for blade to stop rotating before raising implement hood or swings.
- Stop look and listen before approaching the implement to make sure all rotating motion has stopped.
- If a material blockage occurs in the inlet or discharge areas, shut down tractor engine, disengage the PTO and wait for all rotating motions to stop. Place the tractor in park position, engage the parking brake and remove the key before leaving the operator's seat. Clear the blockage before processing. Be sure to keep feet and hands clear of the blades. If you raise the implement or swing to access the blockage, engage the swing lock up latch and securely block up the implement before placing any parts of the body beneath the implement.

Maintenance Safety

- Good maintenance is your responsibility. Poor maintenance is an invitation to trouble.
- Follow good shop practices.
- Keep service area clean and dry.
- Be sure electrical outlets and tools are properly grounded.
- Use adequate light for the job at hand.
- Make sure there is plenty of ventilation. Never operate the engine of the tractor in a closed area. The exhaust gas may cause healthy problem.
- Before maintenance, shut off the tractor (See [Tractor Shutdown](#)).
- Allow equipment to cool before maintenance operation.
- Never work under the machine unless it is secured by a mechanical stand.
- Use personal protection devices such as safety goggles, hand gloves and hearing protectors, when performing any service or maintenance work. Use heavy gloves when handling blades.
- Only use original parts for service and maintenance.

- A fire extinguisher and first aid kit should be kept readily accessible while performing maintenance on this equipment.
- Periodically tighten all bolts, nuts and screws and check that all pins are properly installed to ensure unit is in a safe condition.
- Do not weld or torch on galvanized metal as it will release toxic fumes.
- Always make sure any material and waste products from the repair and maintenance of the implement are properly collected and disposed.
- Disconnect battery (If the implement has the battery) ground cable (-) before servicing or adjusting electrical systems or before welding on implement.
- Do not grease or oil implement while it is in operation.
- Do not work under any hydraulically supported equipment. It can settle, suddenly leak down, or be lowered accidentally. If it is necessary to work under the equipment, securely support it with stands or suitable blocking beforehand.
- When completing a maintenance or service function, make sure all safety shields and devices are installed before placing machine in service.

Preparation before Maintenance

- Be prepared if a fire starts.
- Keep a first aid kit and fire extinguisher handy.
- Keep emergency numbers for ambulance, hospital and fire department near the working area.

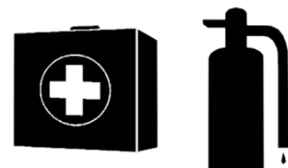

Personal Protective Equipment

- Wear protective clothing and equipment appropriate for the job such as safety shoes, safety glasses, hard hat, dust mask, and ear plugs.
- Clothing should fit snug without fringes and pull strings to avoid entanglement with moving parts.
- Prolonged exposure to loud noise can cause hearing impairment or hearing loss. Wear suitable hearing protection such as earmuffs or earplugs.
- Operating a machine safely requires the operator's full attention. Avoid wearing headphones while operating equipment.



Keep Riders off Machinery

- Never carry riders on the tractor or implement.
- Riders obstruct operator's view and interfere with the control of the power machine.
- Riders can be struck by objects or thrown from the equipment.
- Never use the tractor or implement to lift or transport riders.

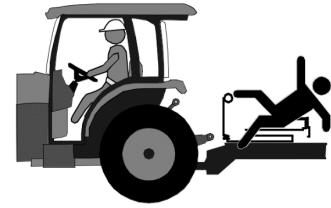

Safety Lights and Devices

- A slow moving power machine can create a hazard when driven on public roads. They are difficult to see, especially at night.
- Flashing warning lights and turn signals are recommended whenever driving on public roads.
- For tractors and other agriculture equipment, a Slow Moving Vehicle (SMV) sign is required when traveling on public roads.

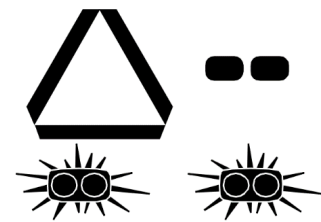

Seat Belt and ROPS

- We recommends the use of a CAB or roll-over-protective structures (ROPS) and seat belt in almost all power machines. Combination of a CAB or ROPS and seat belt will reduce the risk of serious injury or death if the power machine should be upset.
- If ROPS is in the locked-up position, fasten seat belt snugly and securely to help protect against serious injury or death from falling and machine overturn.



Hydraulic System Safety

- Escaping fluid under pressure will penetrate the skin or eyes causing serious injury.
- Relieve all residual pressure before disconnecting hydraulic lines or performing work on the hydraulic system.
- Make sure all hydraulic fluid connections are properly tightened/torqued and all hydraulic hoses and lines are in good condition before applying pressure to the system.
- Use a piece of paper or cardboard, NOT BODY PARTS, to check for suspected leaks.



- Wear proper hand and eye protection when searching for a high pressure hydraulic leak. Use a piece of wood or cardboard as a backstop instead of hands to isolate and identify a leak.
- DO NOT DELAY. If an accident occurs, seek immediate emergency medical care or gangrene may result.



Handle Chemicals Properly

- Protective clothing should be worn.
- Handle all chemicals with care.
- Follow instructions on container label.
- Agricultural chemicals can be dangerous. Improper use can seriously injure persons, animals, plants, soil, and property.
- Inhaling smoke from any type of chemical fire can be a serious health hazard.
- Store or dispose of unused chemicals as specified by the chemical manufacturer.



Tire Maintenance Safety

- Tire changing can be dangerous and must be performed by trained personnel using the correct tools and equipment.
- Always properly match the wheel size to the properly sized tire.
- Always maintain correct tire pressure. Do not inflate tires above recommended pressures shown in the Operator's Manual.
- When inflating tires, use a clip-on chuck and extension hose long enough to allow you to stand to one side and NOT in front of or over the tire assembly. Use a safety cage if available.
- Securely support the implement when changing a wheel.
- When removing and installing wheels, use wheel handling equipment adequate for the weight involved.
- Make sure wheel bolts have been tightened to the specified torque.



Storage and Disposal Safety

Storage Safety

1. Store the machine in an area away from human activity. Do keep the machine out of the children's reach. Do not permit children to play on or around the stored machine.
2. Store the machine in a dry, level area.
3. Clean grease and oil as required and protect it from the elements.

Disposal Safety

1. Improper disposal of oil or other waste may be hazardous to the environment.
2. When oil is emptied from the machine, it must be poured into a leak-proof container suitable for oil. It is not permissible to store oil in a container used for food or drink, in order to avoid the oil being consumed by mistake and causing serious injury. It is prohibited to spill oil on the ground, or pour it into a drain or anywhere leading to a water source.
3. Discarded oil, fuel, coolant, brake fluid, filters and batteries may not be thrown away or emptied in just any way. Contact your local authority for further information.

Safety Labels

Your implement comes equipped with all safety labels in place. They were designed to help you safely operate your implement. Read and follow their directions.

1. Keep all safety labels clean and legible.
2. Replace all damaged or missing labels.
3. When ordering new components make sure the correct safety labels are included in the request.
4. Refer to steps below for proper label placement.
 - a) Clean surface area where label is to be placed.
 - b) Spray soapy water onto the cleaned area.
 - c) Peel backing from label and press label firmly onto the surface.
 - d) Squeeze out air bubbles with edge of a card or with a similar type of straight edge.

Labels Location

Labels locations below are common practices of ME-RT72-M machine that may or may not be applicable to the products described in this manual.

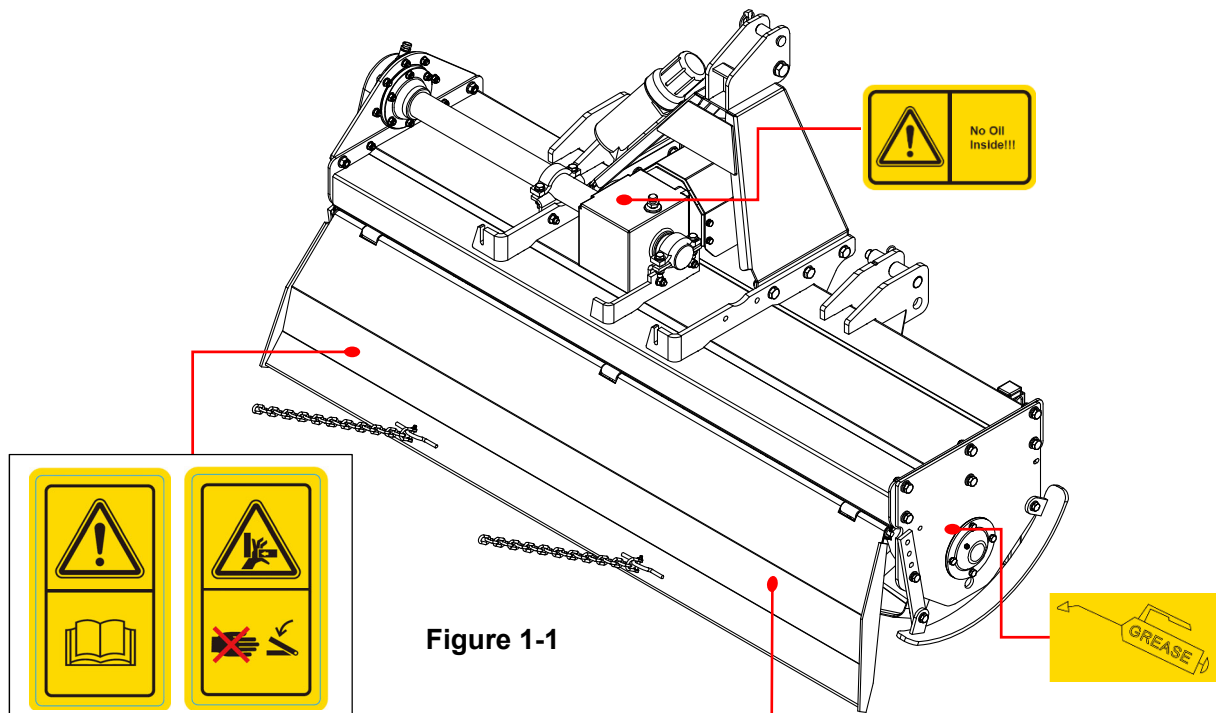

Figure 1-1

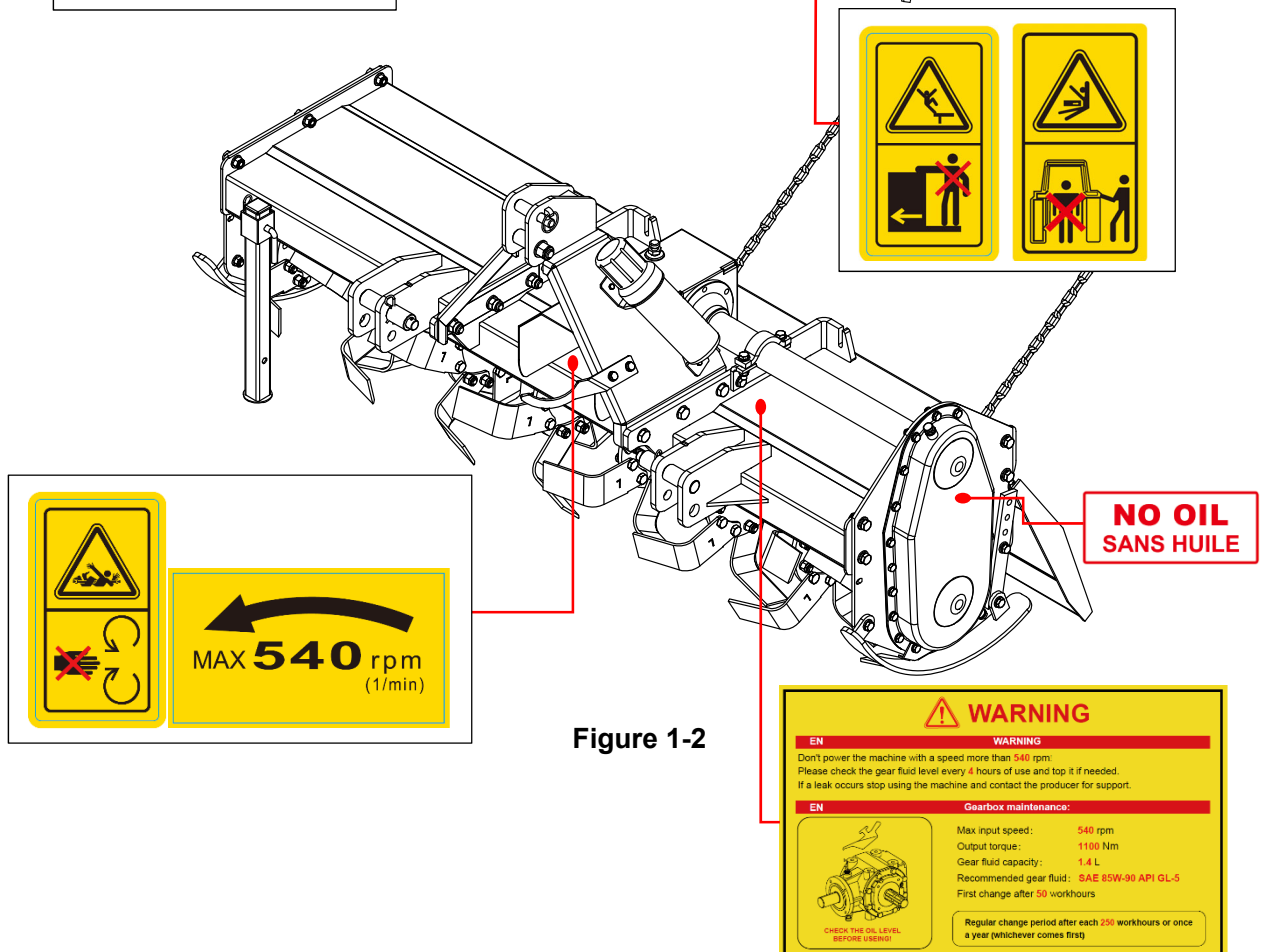



Figure 1-2

⚠ WARNING	
<p>EN Don't power the machine with a speed more than 540 rpm. Please check the gear fluid level every 4 hours of use and top it if needed. If a leak occurs stop using the machine and contact the producer for support.</p>	
WARNING	
EN Gearbox maintenance:	
 <small>CHECK THE OIL LEVEL BEFORE USING!</small>	<p>Max input speed: 540 rpm Output torque: 1100 Nm Gear fluid capacity: 1.4 L Recommended gear fluid: SAE 85W-90 API GL-5 First change after 50 workhours</p>
	<p>Regular change period after each 250 workhours or once a year (whichever comes first)</p>

PRODUCT INTRODUCTION

Listed figure is common tiller of ME-RT72-M that may or may not be applicable to the products described in this manual.

See Figure 2

This rotary tiller is a kind of medium-sized rotary cultivator, which can effectively cut the root stubble buried below the surface to break the plow bottom, restore the soil topsoil structure, improve the soil water retention capacity, eliminate some weeds, reduce diseases and pests, and provide a good seed bed for subsequent sowing operations. This product has the characteristics of strong soil crushing ability and flat surface after ploughing.

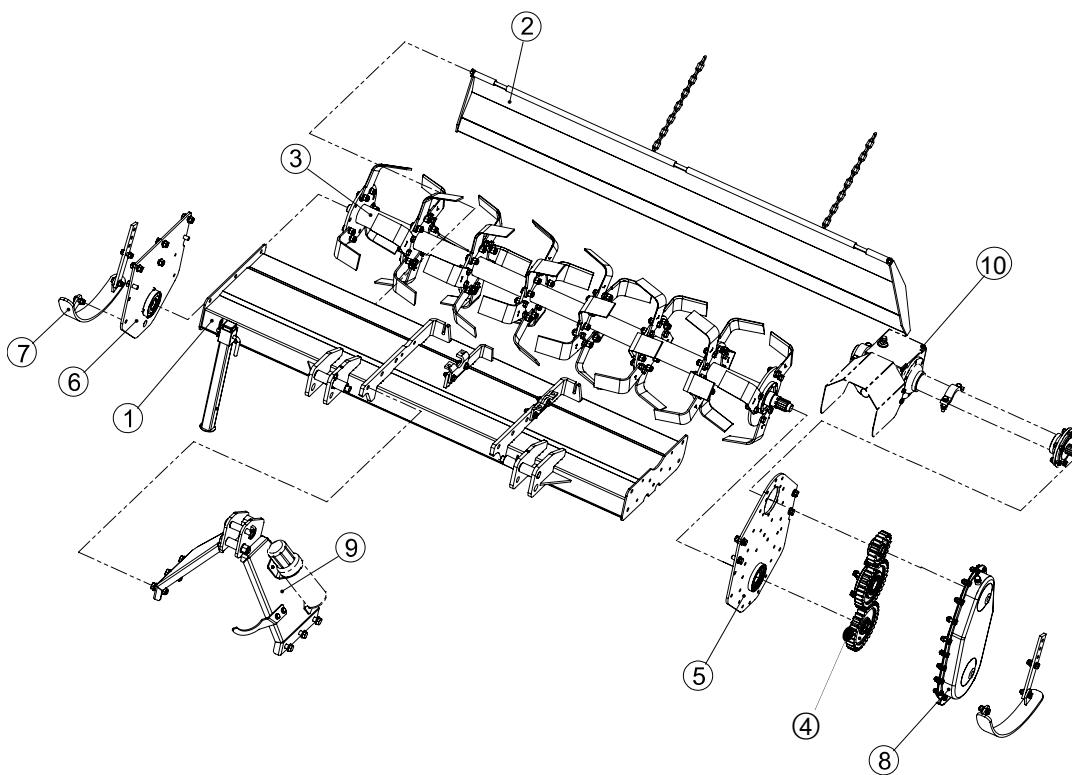

Figure 2

Main parts name and function list:



Item	Name	Functional Description
1	Top cover	Protects operator and bystanders from debris.
2	Rear deflector	See chapter Adjusting Rear Deflector .
3	Knife shaft	Durable heat-treated alloy steel blade which can reduce the loading during operation.
4	Gear driven system	Transmits power and motion from PTO shaft to knife shaft by means of successive engagement of teeth.

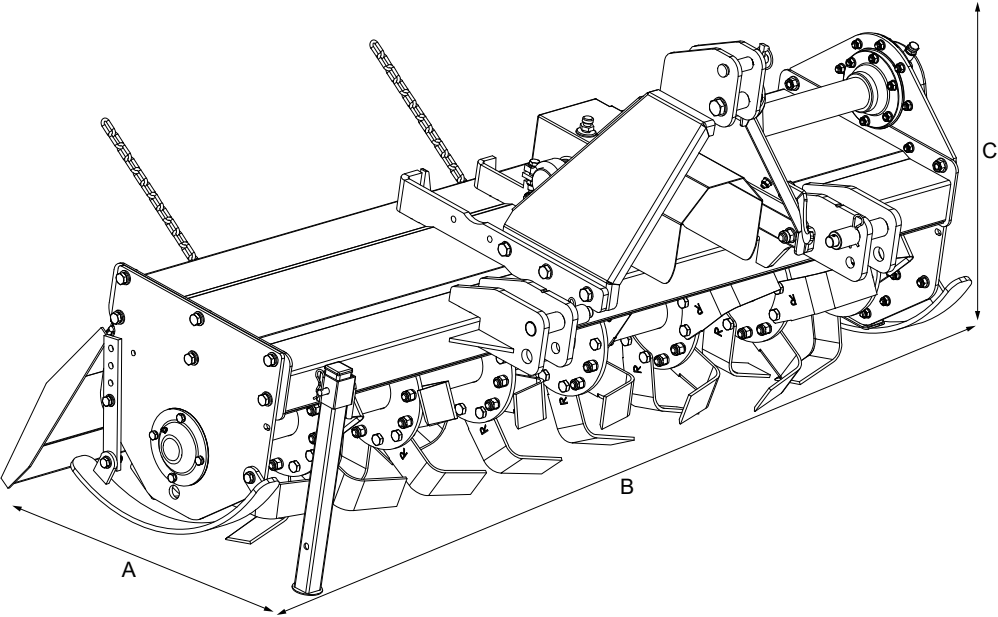

Item	Name	Functional Description
5	Right panel	Avoid damaging the surface of the machine during operation process.
6	Left panel	
7	Skid shoes	Skid shoes are used for support when the tiller is in idle, and it plays a guiding role during operation. And adjustable skid for easy adjustment of ploughing depth.
8	Protection panel	Protects the side driver from damage.
9	Hitch component	Connect to tractor via 3-point suspension, and the feet will be supported the tiller when it is in the maintenance or storage status.
10	Gearbox	Connect with PTO component.



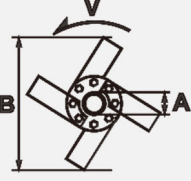

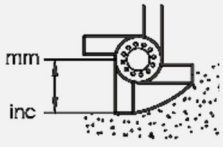
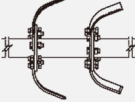
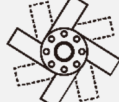
Technical Data

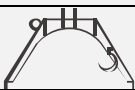

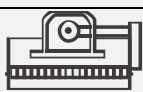
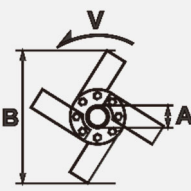

Implement specification table:

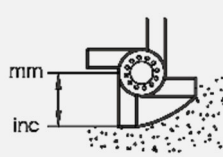
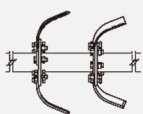
Model		ME-RT36-M	ME-RT40-M
A(Depth)		860	
B(Width)	mm	1110	1180
C(Height)		1040	
	mm	900	1000
	A (mm)	76	
	B (mm)	500	
	V (m/s)	5.5	
	HP	50	
	mm	210	
	rpm	210	
	in	8.3	
	N	4	5
	N	18	24

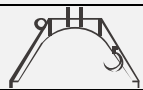
Model		ME-RT36-M	ME-RT40-M
	PTO (rpm)	540	
	CAT.	CAT. I	
	HP	20-60	
	Kg	250	273

Model		ME-RT48-M	ME-RT54-M	ME-RT60-M	ME-RT72-M
A(Depth)	mm	860			
B(Width)		1430	1530	1680	1980
C(Height)		1040			
	mm	1250	1350	1500	1800
	A (mm)	76			
	B (mm)	500			
	V (m/s)	5.5			
	HP	50			
	mm	210			
	rpm	210			
	in	8.3			
	N	6	6	7	8
	N	30	30	36	42
	PTO (rpm)	540			
	CAT.	CAT. I		CAT. I/II	

Model		ME-RT48-M	ME-RT54-M	ME-RT60-M	ME-RT72-M
	HP	20-60			
	Kg	300	304	322	350

Implement Identification

The identification nameplate is affixed to the frame of each implement. It contains: the Manufacturer, Type, Serial Number, Model Number, Weight. The nameplate (Shown in the below) is for reference only and is based on the real thing.

MATENG

TYPE <input style="width: 80%;" type="text"/>	YEAR <input style="width: 80%;" type="text"/>
TYPE <input style="width: 80%;" type="text"/>	ANNÉE <input style="width: 80%;" type="text"/>
SERIAL NO. <input style="width: 80%;" type="text"/>	WEIGHT <input style="width: 80%;" type="text"/>
N° DE SÉRIE <input style="width: 80%;" type="text"/>	POIDS <input style="width: 80%;" type="text"/>

Toll Free: 1-866-718-4746
 info@mateng.ca www.mateng.ca

UNPACKING

After unpacking, please check the components shown in **Figure 3**. If you have any problem, please contact us freely.

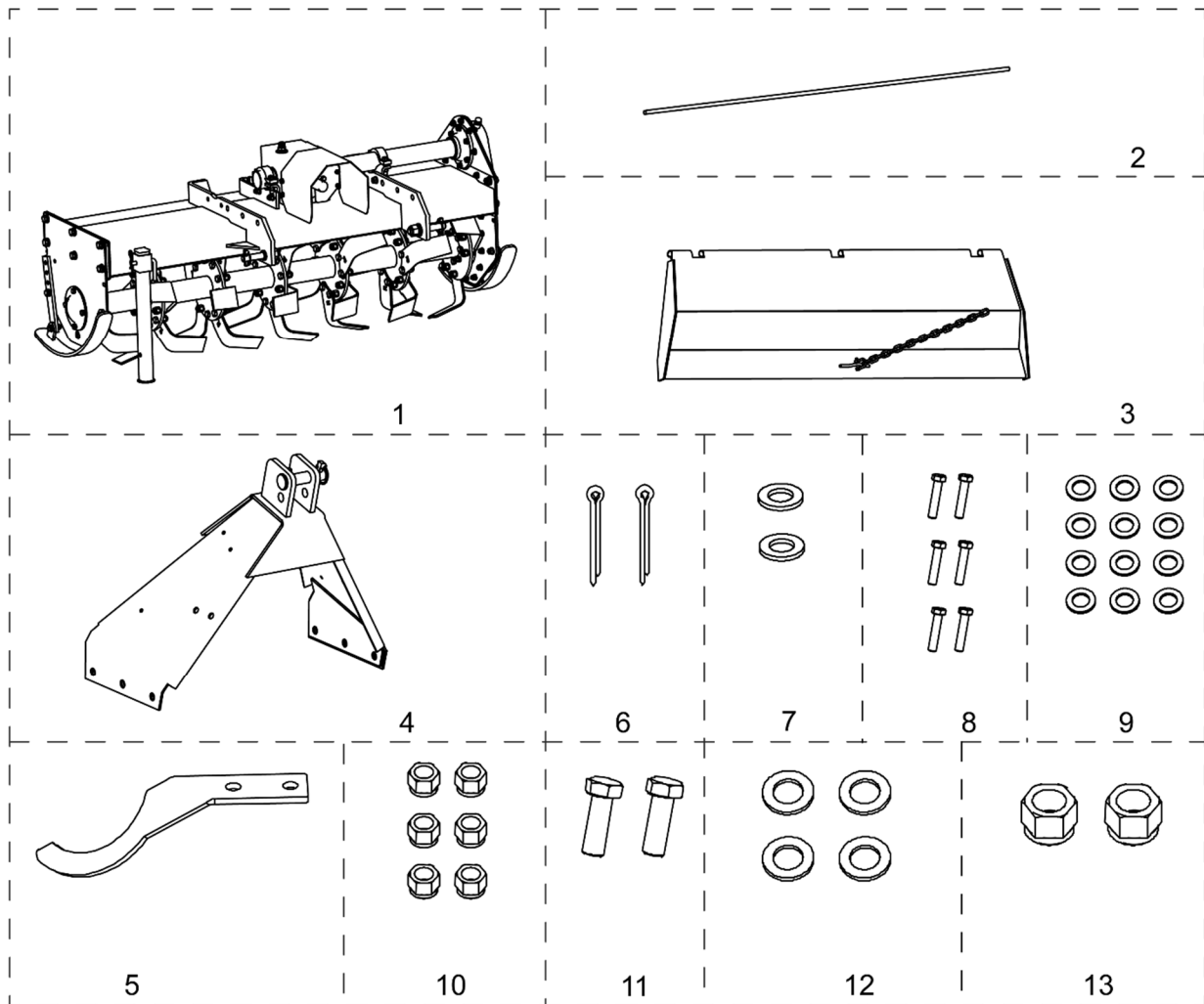

Figure 3

Unpacking parts description list:

Item	Specification	Description	Qty.	Packing
1	/	Host	1	Single pack
2	MTZB00298	Shaft of rear deflector	1	Single pack
3	F06002A05100-000	Rear deflector	1	Single pack
4	F06002A10100-000	Hitch component	1	Single pack
5	F06001A10000-002	PTO location panel	1	Single pack

Item	Specification	Description	Qty.	Packing
6	GB_T91-3.2×25	Hairpin	2	Bale
7	GB_T95-12-EP_Zn	Flat washer	2	Bale
8	GB_T5783-M16×50-8.8-EP-Zn	Hex. Bolt	6	Bale
9	GB_T95-16-EP_Zn	Flat washer	12	Bale
10	GB_T889.1-M16-8-EP_Zn	Hex. locking nut	6	Bale
11	GB_T5783-M10×25-8.8-EP-Zn	Hex. bolt	2	Bale
12	GB_T95-10-EP_Zn	Flat washer	4	Bale
13	GB_T889.1-M10-8-EP_Zn	Hex. locking nut	2	Bale

Tools for installation process list:

No.	Description	Specification	Conditions of Use	Qty.
1	Open end wrench	/	M10/M12ning	2
2	Hex key	/	M10/M12 fastening	1
3	Hammer	/	/	1
4	Torque wrench	10-220N.m	Measuring torque	1
5	Wind gun	1280t	Match the corresponding sleeve instead of the wrench to tighten the bolt	1

ASSEMBLY & SET-UP

Installing Rear Deflector

To install rear deflector:

1. Align the rear deflector (**A1**) to location holes of host.
2. Insert the shaft (**A4**) through the host and rear deflector.
3. Bolt the rear deflector using a bolt flat washer (**A2**), assemble as shown below and tighten it with hairpin (**A5**), see figure below.

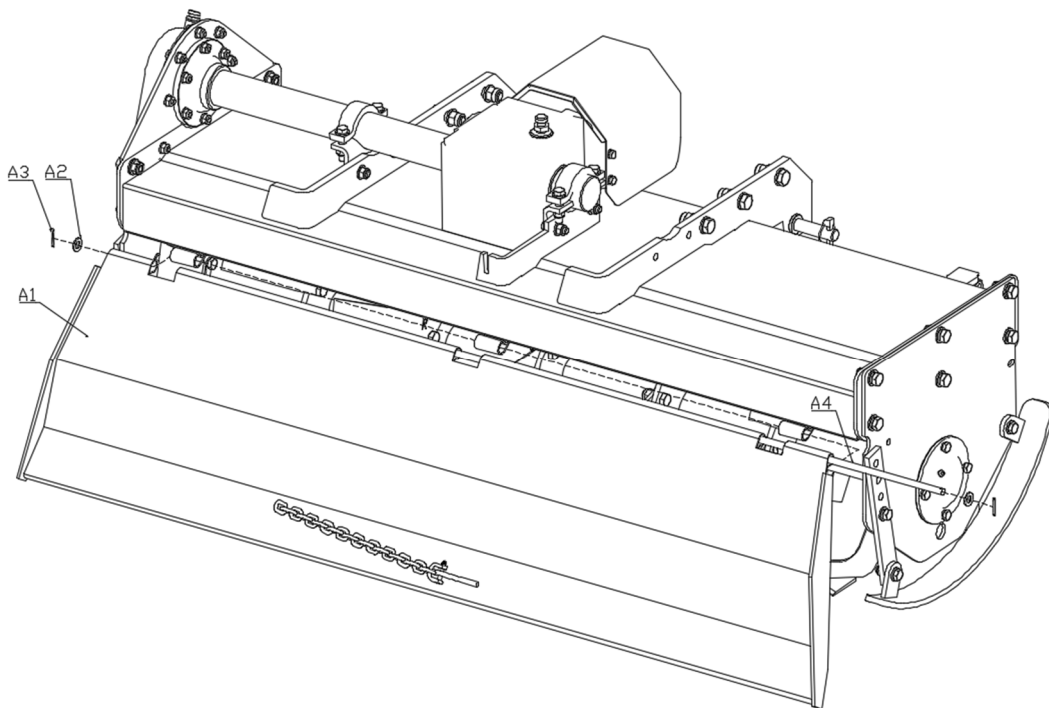

Figure 7

Connecting Hitch to Tiller

To connect hitch to tiller:

1. Align the installation holes of right and left panels of hitch component (**B1**) to connection position of host, see figure below.
2. Bolt the left panel holes of hitch (**B1**) to the outside of host, using four bolts M16*50 (**B6**), flat washers (**B7**), assemble as shown below and tighten it with hex. nut M16 (**B8**).
 - The head of the bolt should be on the outside of the hitch component with the washer and hex. nut with flat washer.
3. Repeat step 2 to install the right panel of hitch component.
4. Bolt the PTO panel (**B2**) to the right top of hitch component, using two bolts M10*25 (**B3**), flat washers (**B4**), assemble as shown below and tighten it with hex nut M10 (**B5**).
 - The head of the bolt should be on the outside of the PTO panel with the washer and hex. nut with flat washer on the inside of hitch.

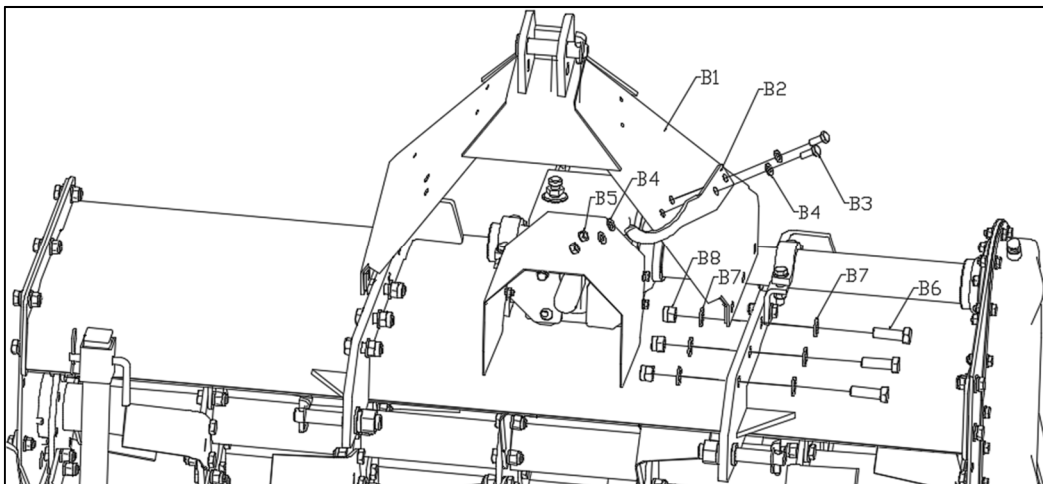

Figure 5

Tractor Shutdown

The following are basic tractor shutdown procedures. Follow these procedures and any additional shutdown procedures provided in your tractor Operator's Manual before leaving the operator's seat.

1. Reduce engine speed and disengage power take-off if engaged.
2. Park tractor and implement on level, solid ground.
3. Lower implement to ground or onto non-concrete support blocks.

NOTE: Due to the over running clutch, the rotor blades will continue to spin after the driveline stops.

4. Put tractor in park or set park brake, turn off engine, and remove switch key to prevent unauthorized starting.

5. Relieve all hydraulic pressure to auxiliary hydraulic lines.
6. Wait for all components to come to a complete stop before leaving the operator's seat.
7. Use steps, grab-handles and anti-slip surfaces when stepping on or off the tractor.

Tractor Hook-up

WARNING

- A crushing hazard exists while hooking-up and unhooking the implement. Keep people and animals away while approaching the implement or pulling away from the implement. Do not operate hydraulic controls while a person or an animal is nearby.
- Always follow "[Tractor Shutdown](#)" to power off.
- Tractor horsepower and hitch category should be within the required range. The lower 3-Point arms must be stabilized to prevent side-to-side movement.

Note:

- This tiller is featured with a hitch design. Attaching a tiller to the front of a tractor typically follows a similar process to attaching it to the rear, although there may be some differences based on the specific tractor. Make sure the tiller is compatible with your tractor's attachment system.
- There are one pair of extra hitch pins delivered at your disposal.

See Figure 8

1. Be certain tractor drawbar does not interfere. Move drawbar ahead or remove if required.
2. Remove all hitch pins and linchpins.
3. Attach tractor's top center link and lower arms with 3-point hitch correspondingly and secure with pins accordingly.
4. The upper clevis has slots to compensate for uneven ground and to keep the roller in contact with the ground. After setting the work height, adjust the length of the top center link until hitch pin is close to the rear of the slot to ensure that the tiller will work correctly.
5. The lower arms of a 3-point hitch for an offset/vertical tiller has one end longer than the other to accommodate the offset design of the tiller. This allows the tiller to reach areas that a center-mounted tiller cannot, such as along fence lines or ditches.

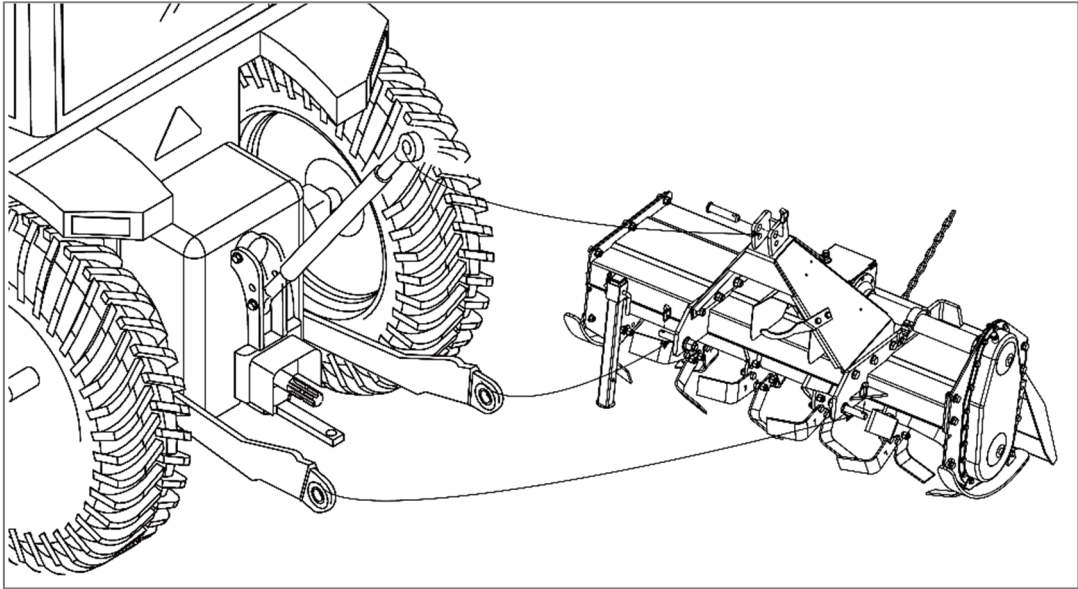
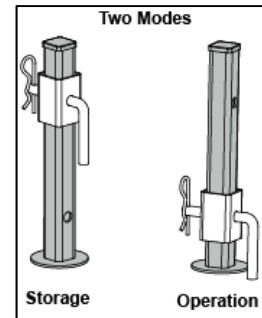

Figure 8

⚠ WARNING

There are two modes of leg can be installed, the storage is for transportation or long time no use, and the operation is for working process.



Driveline Installation

Listed below are common practices that may or may not be applicable to the products described in this manual.

Note: There are 3 types of PTO shafts available.

⚠ DANGER

- Do not engage tractor PTO while hooking-up and unhooking the prop shaft or stand near a rotating prop shaft. A person's body and/or clothing may get entangled to cause severe injury.
- Do not use a power take-off adapter. The adapter will increase strain on the tractor's power take off shaft causing possible damage to shaft and driveline. It will also defeat the purpose of the tractor's power take-off shield.
- Make certain driveline yokes are securely fastened at each end. A loose yoke can work free allowing the driveline to rotate uncontrollably.

Type A shaft has interchangeable ends for installation;

Type B shaft shall have the end where safety pin locates connected with the implement;

Type C shaft shall have end where the clutch locates connected with the implement.

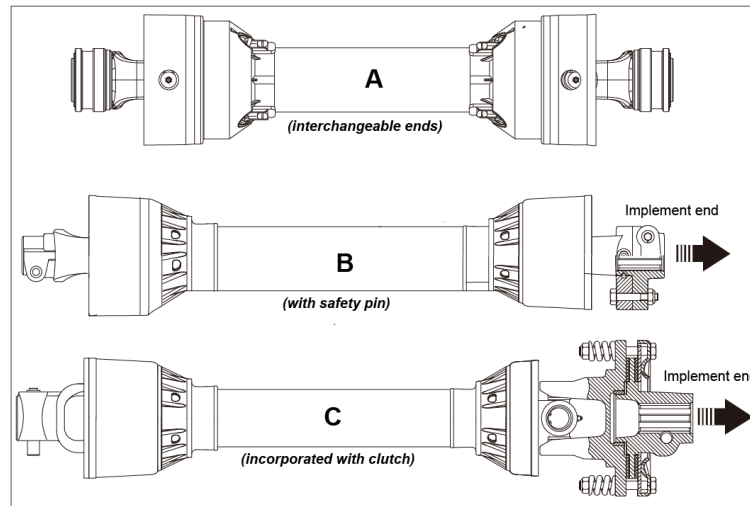

Figure 9

1. Park tractor on a level surface. Slowly engage tractor 3-Point lift lever to raise implements until gearbox shaft is in line (level) with tractor PTO shaft.
2. Support implements deck at this height with support jacks or blocks to keep implement from drifting down.
3. Place gear selector in park, set park brake, shut tractor off, and remove switch key.
4. Slide inner yoke (implement end) of driveline onto the gearbox. Secure driveline with yoke locking device.
5. Slide outer yoke of driveline over the tractor PTO shaft. Secure driveline with yoke locking device
6. If the driveline is too long and does not fit between tractor and gearbox, skip to **Customize Driveline** to shorten the driveline.
7. The driveline should now be moved back and forth to ensure secured connection at both ends. Reattach any end that is loose. Go to **Driveline Length Check** to ensure proper accommodation.
8. Hook driveline safety chain on the tractor end of driveline to the tractor. Re-latch safety chain to the driveline shield.
9. Hook driveline safety chain on the implements end of driveline to the implements frame. Re-latch safety chain to the driveline shield.

Driveline Length Check

Before operating the implement, ensure that the size of driveshaft is adequate. The driveshaft supplied with the machine has a standard length, therefore it may need an adaptation of the length, depending of the tractor which the implement is attached with.

Maximum compressed position

The power take-off shaft and gearbox input shaft must be aligned and level with each other when checking driveline minimum length. A driveline that is too long can damage tractor and implement.

See Figure 10

Hold inner and outer drivelines parallel to each other as shown and measure distance **L1**:

1. If **L1** is less than 1" (2.5 cm), skip to [Customize Driveline](#) to shorten the driveline.
2. If **L1** is greater than or equal to 1" (2.5 cm), skip to [Maximum Extended Position](#) below.

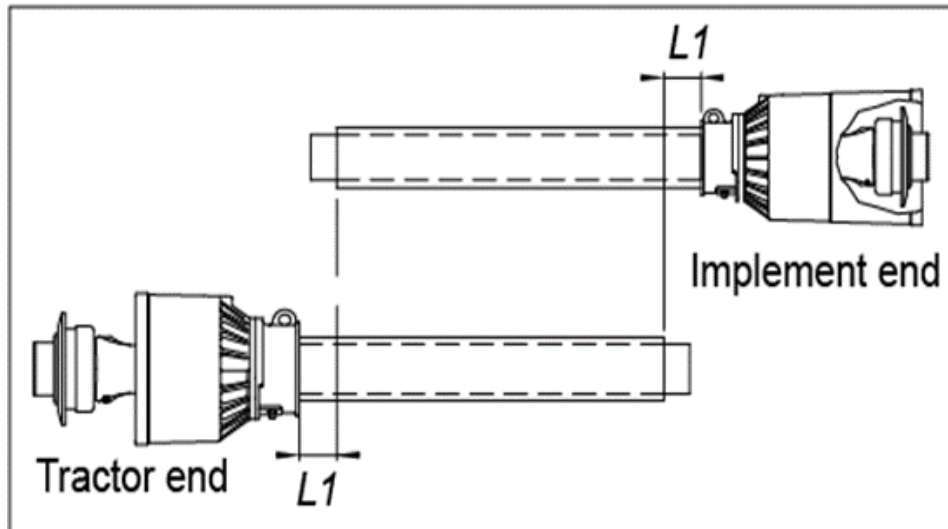

Figure 10

Maximum Extended Position

See Figure 11

The driveline maximum allowable length must, when fully extended, have a minimum overlap (**L2**) of profile tubes by not less than 1/3 the free length with both inner and outer profile tubes being of equal length.

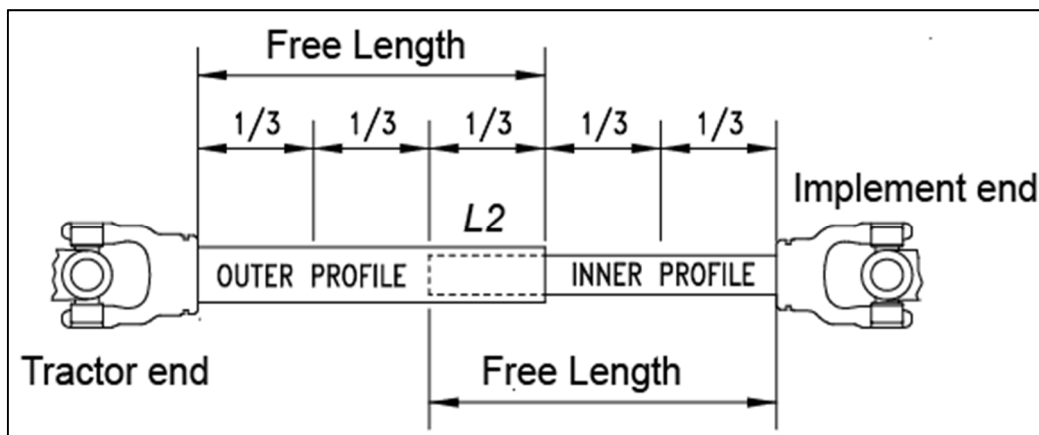

Figure 11

Customize Driveline

See Figure 12

1. Un-hook driveline from tractor PTO shaft and pull outer and inner drivelines apart.
2. Re-attach outer driveline to tractor PTO shaft. Pull on inner and outer drivelines to be sure universal joints are properly secured.
3. Hold inner and outer drivelines parallel to each other:
 - a. Measure 1" (2.5 cm) ("**L1**" dimension) back from outer driveline universal joint shield and make a mark at this location on the inner driveline shield.
 - b. Measure 1" (2.5 cm) ("**L1**" dimension) back from the inner driveline universal joint shield and make a mark at this location on the outer driveline shield.
4. Remove driveline from tractor and gearbox shafts.
5. Measure from end of inner shield to scribed mark ("**X**" dimension). Cut off inner shield at the mark. Cut same amount off the inner shaft ("**X1**" dimension).
6. Measure from end of outer shield to scribed mark ("**Y**" dimension). Cut off outer shield at the mark. Cut same amount off the outer shaft ("**Y1**" dimension).
7. Remove all burrs and cuttings.
8. Apply multi-purpose grease to the inside of the outer shaft and reassemble the driveline.

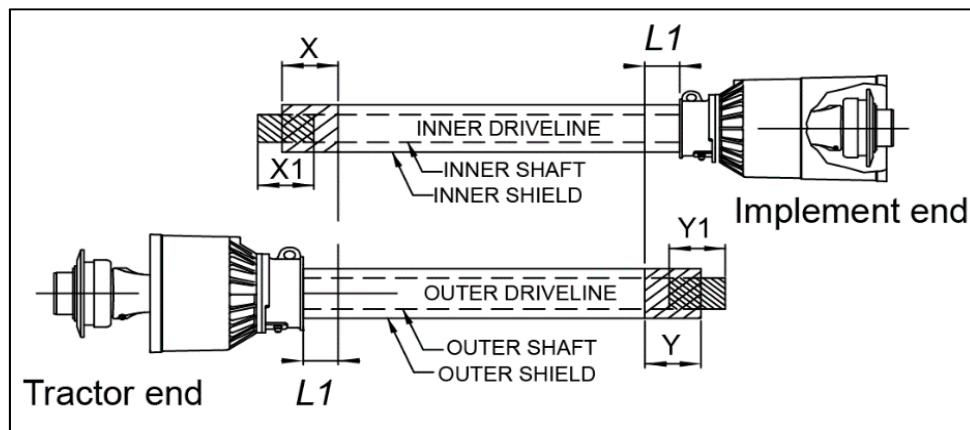

Figure 12

Driveline Interference Check

See *Figure 13*

Lowly engage tractor 3-Point control lever to lower implements while checking for sufficient tongue clearance. Move tongue ahead, aside, or remove if required.

1. Raise and lower implement to find maximum extended driveline length. Check to make certain the driveline does not exceed the maximum allowable length and lift it up or down in a reasonable range.
2. If needed, set tractor 3-Point lift height to keep driveline from exceeding the maximum allowable length and lift it up or down.

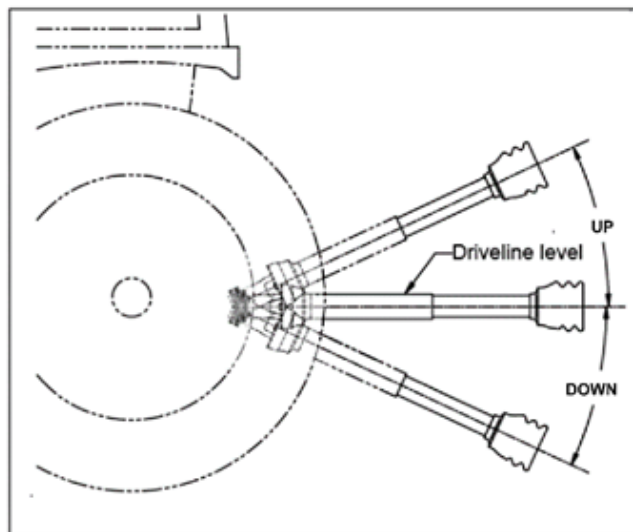

Figure 13

Note: If you have any problem during operation, please contact us freely!

OPERATION

General Operating Instructions

Now that you have familiarized yourself with the Operator's Manual, completed the Operators Checklist, properly attached your implements to your tractor, made the right offset or center adjustments, and preset your tilling height, you're almost ready to begin using the implement.

- Now that you have properly prepared yourself and your tiller, it's time to do some tilling.
Carefully drive the tractor to the site where you intend to till. You should have already cleared this site of any large limbs, rocks, trash, metal or other debris. Lower the tiller half way to the ground and reduce your tractor engine speed to about one quarter throttle. Engage the power take-off and gradually increase the engine speed until you reach full power take-off speed of 540 rpm. Lower the tiller to the ground and simultaneously commence forward travel of approximately 2 mph (3.2 km/h). Do not make turns or attempt to back up while tiller is in the ground. See important note below.
- Travel about 50 feet (15 m) and then stop to check your results. When stopping, remember to stop tractor, lift tiller slightly out of the ground, reduce engine speed, disengage power take-off, set park brake, shut off tractor, and remove the key. If you are tilling too shallow or too deep, adjust the skid shoes accordingly. If the soil texture is too coarse, lower the rear deflector and reduce your ground speed. If the soil texture is too fine, you will need to raise your rear deflector and increase your ground speed. For any other problem conditions that may arise, refer to the ["Troubleshooting"](#) .
- When you are done tilling for the day, make sure you use proper tractor shutdown procedures before you get off of the tractor. If you are detaching your tiller, make sure you park it on a dry and level surface leaving it clean and ready for the next use.
- With a little practice and a few adjustments, you will soon be achieving the results you want with your Land Pride Rotary Tiller. Do not operate close to ditches or creeks. Slow down when operating over rough ground.
- Always be sure the implement is in the fully raised position when in transport.
- When adjusting the assembly, be sure that your feet are never under the rotary tiller.
- Use extreme caution when backfilling deep holes or trenches.
- Be careful to avoid catching the rotary tiller on stumps or other immovable objects.
- Use care when working on slopes.

! CAUTION

Engage parking brake, shut off tractor, remove key, and disengage PTO before making any adjustments!

! CAUTION

Ensure implement with special supports if it is necessary to lift implement off the ground to make adjustments! If not supported, the implement could fall causing serious injury to those present.

Checklist before Operation

CAUTION

Hazard control and accident prevention are dependent upon the awareness, concern, prudence, and proper training involved in the operation, transport, storage, and maintenance of the implement. Therefore, it is absolutely essential that no one operates the machine without first having read, fully understood, and become totally familiar with the Operator's Manual. Make sure all operators have completed the Checklist below.

Before operating the machine, the following steps should be inspected carefully:

Before starting up the machine, check and lubricate all grease points, on the machine and drive shaft.

Check the oil level in the gearbox. Add as required.

Use only an agricultural tractor with horsepower within limits of the implement.

Check that the machine is properly attached to the tractor. Be sure retainers are used on the mounting pins.

Be sure extra weights are mounted on the front of the tractor, if required.

Check that the tractor PTO shaft turns freely and that the machine driving shaft can telescope easily.

Check the blades. Be sure they are not damaged or broken and swing freely in their mount. Repair or replace as required.

Check and tighten the blade bolts.

Check for entangled material in all rotating parts. Remove this material.

Install and secure all guards, hook and covers before starting.

Before installing the PTO ensure the engine is stopped and the PTO shaft is in safe working order.

All other people shall leave the area before connecting the driving power from the tractor.

Before cleaning, repairing and lubricating the machine, stop the motor and take the key away with you.

When the PTO shaft is not connected with the tractor, support it through the frame to protect it from lying in the dirt.

Don't approach the machine when it is operating.

Clear area to be tilled of rocks, branches, and other foreign objects.

Tall grass and weeds should be mowed before tilling.

Tilling should not be done in wet conditions as soil will stick to tines.

At first begin tilling at a slow forward speed and shift up as ground conditions warrant.

Operate tiller with deck level to the ground.

After tilling the first 50 feet (15 m), stop and check to see that the tiller is adjusted properly.

Levelling the Tiller

Levelling adjustments are made at the tractor's 3-Point lower arms and top center link.

1. Park tractor and implement on a flat level surface.
2. Raise implement with the tractor's Hydraulic 3-Point lift slowly until the unit is about 1 to 2" above the ground.
3. Ensure that the lower arms are stabilized to prevent excessive side movement.
4. Place a spirit level on the top cover running from left to right and adjust one of the lower 3-Point arms up or down until the implement is level from left to right.
5. Adjust tractor's top center link to place the upper hitch pin vertically above or slightly behind the lower hitch pins.
6. Slowly operate the tractor's 3-Point hydraulic control up and down to check for clearance between the tires, frame, drawbar.

Adjusting Rear Deflector

To adjust rear deflector:

1. Rear deflector (#3) can be adjusted closer to the ground to produce a fine soil texture or raised to produce a coarse soil texture.
2. Adjust rear deflector up or down by repositioning chain (#2) in slot (#1).

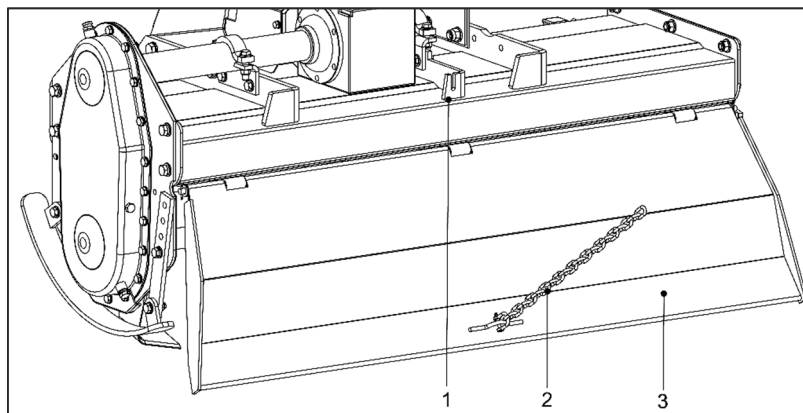

Figure 14

Adjusting Park Stand

CAUTION

To avoid serious injury or death:

An unsupported parked tiller can tip over easily. Always use its park stand and when needed, non-concrete support blocks to keep the tiller from tipping onto a person.

See figure 15

1. Hook-up tiller to a tractor, see [Tractor Hook-up](#).
2. Lower tiller until skid shoes (#6) are resting on support blocks. Park stand feet (#1) should be off the ground by several inches.
3. Shut tractor down before dismounting using [Tractor Shutdown](#).
4. Remove R pin (#3), and L-Pin (#2).
5. Adjust park stand feet (#1) to realign 1 of 2 holes “#8” with mounting holes “#7”.
6. Attach stand (#1) to center holes in park stand mount (#5) with L-Pin (#2) and R Pin (#3).

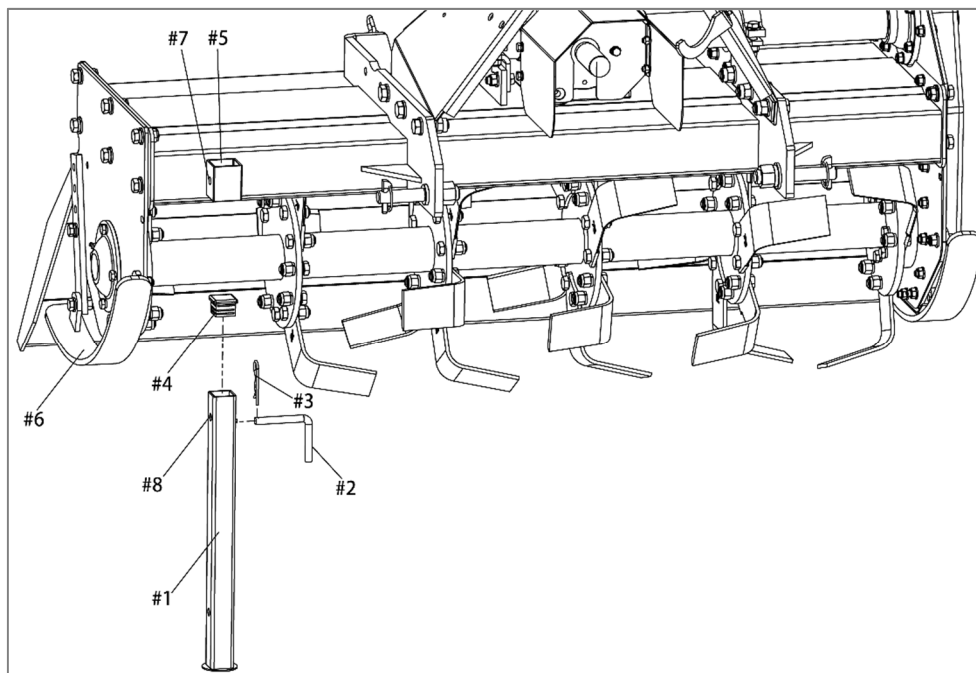
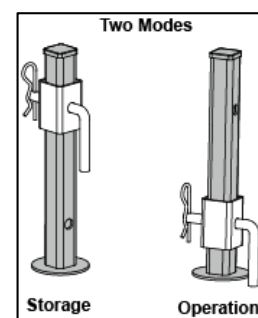

Figure 15

WARNING

There are two modes of leg can be installed, the storage is for transportation or long time no use, and the operation is for working process.



SERVICE AND MAINTENANCE

General Service

The period recommended is based on normal operating conditions. Severe or unusual conditions may require more frequent service.

Each 4 hours of work:

Check and tighten nuts and bolts.

Grease with lithium based grease when it is indicated by the symbol GREASE.

After 50 hours of work:

Check and fill the gearbox to the required level, using oil type SAE EP 90W.

Gearbox Maintenance

The oil should be drained out and replaced after the first 50 hours of operation. Then the oil should be changed every 250 hours.

Drain oil from the gearbox thoroughly. Check and clean it. Fill with new gear oil up to the dedicated oil level.

The draining procedure is as follows: remove the draining bolt under the gear box, so that the oil drains off. After the oil is drained out, put the plug back and fill with gear oil up to the dedicated oil level.

PTO Shaft Maintenance





It is recommended to lubricate the PTO shaft with multi-purpose grease after every 8 to 10 hours of use during heavy use. The PTO shaft is designed to telescope to allow for dimensional changes as the machine goes through its operating range. A tubular guard encloses the driving components and is designed to turn relative to the driving components. The shaft should telescope easily and the guard turn freely on the shaft at all times. Annual disassembly, cleaning and lubrication is recommended to insure that all components function as intended. To maintain the shaft, follow this procedure:

1. Remove the shaft from the machine.
2. Pull shaft apart.
3. Use a screwdriver to pry the tabs out of the sleeves on each end.
4. Pull the shaft out of the plastic tubular guard.



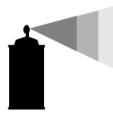

5. Use a solvent to clean the male and female portions of the telescoping ends.
6. Apply a light coat of grease to each end.
7. Clean the grooves on each end where the tabs are located. Clean each tab also.
8. Apply a light coat of grease to each groove.
9. Insert the shaft into its respective guard and align the slots with the groove.
10. Insert the tabs through the slots and seat in the groove.
11. Check that each guard turns freely on the shaft.
12. Assemble the shaft.
13. Check that the shaft telescopes easily.
14. Replace any components that are damaged or worn.
15. Install the shaft on the machine.



Lubrication Parts

Lubrication legend list:

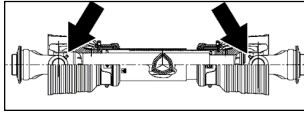
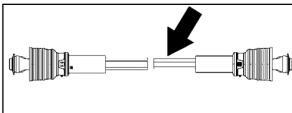
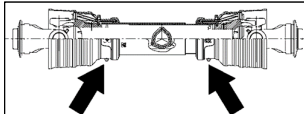
Name	Multi-purpose spray lube	Multi-purpose grease lube	Multi-purpose oil lube	Intervals in hours at which lubrication is required
Image				

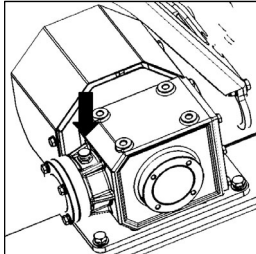
Lubrication parts list:

Interval	Type	Name	Parts Image	Remark
	 Multi-purpose Grease	Driveline Shaft U-Joints		Quantity - 4 to 8 Pumps
		Driveline Profiles		Quantity - Clean & coat inner profile tube of driveline with a light film of grease and then reassemble.
		Inner Tube Bearings		Quantity - As Required
	 SAE EP 90W Gear Lube	Gearbox		Add visual to the center of the gear oil Reinstall plugs and tighten. Do not overfill!

Interval	Type	Name	Parts Image	Remark
				Should your gearbox require service, take it to your Manufacturer dealer.
	 Multi-purpose Grease	Other parts	If the GREASE labels () are posted on the machine, you need to lubricate it regularly. Recommend lubrication interval is 25hours.	

Tightening Torque

Please follow the table below to identify the torque value as required.

Torque Values Chart for Common Bolt Sizes													
Bolt Size (inches)	Bolt Head Identification						Bolt Size (Metric)	Bolt Head Identification					
	Grade 2		Grade 5		Grade 8			Class 5.8		Class 8.8		Class 10.9	
in-tpi ¹	N · m ²	ft-lb ³	N · m	ft-lb	N · m	ft-lb	mm x pitch ⁴	N · m	ft-lb	N · m	ft-lb	N · m	ft-lb
1/4" - 20	7.4	5.6	11	8	16	12	M 5 X 0.8	4	3	6	5	9	7
1/4" - 28	8.5	6	13	10	18	14	M 6 X 1	7	5	11	8	15	11
5/16" - 18	15	11	24	17	33	25	M 8 X 1.25	17	12	26	19	36	27
5/16" - 24	17	13	26	19	37	27	M 8 X 1	18	13	28	21	39	29
3/8" - 16	27	20	42	31	59	44	M10 X 1.5	33	24	52	39	72	53
3/8" - 24	31	22	47	35	67	49	M10 X 0.75	39	29	61	45	85	62
7/16" - 14	43	32	67	49	95	70	M12 X 1.75	58	42	91	67	125	93
7/16" - 20	49	36	75	55	105	78	M12 X 1.5	60	44	95	70	130	97
1/2" - 13	66	49	105	76	145	105	M12 X 1	90	66	105	77	145	105
1/2" - 20	75	55	115	85	165	120	M14 X 2	92	68	145	105	200	150
9/16" - 12	95	70	150	110	210	155	M14 X 1.5	99	73	155	115	215	160
9/16" - 18	105	79	165	120	235	170	M16 X 2	145	105	225	165	315	230
5/8" - 11	130	97	205	150	285	210	M16 X 1.5	155	115	240	180	335	245
5/8" - 18	150	110	230	170	325	240	M18 X 2.5	195	145	310	230	405	300
3/4" - 10	235	170	360	265	510	375	M18 X 1.5	220	165	350	260	485	355
3/4" - 16	260	190	405	295	570	420	M20 X 2.5	280	205	440	325	610	450
7/8" - 9	225	165	585	430	820	605	M20 X 1.5	310	230	650	480	900	665
7/8" - 14	250	185	640	475	905	670	M24 X 3	480	355	760	560	1050	780
1" - 8	340	250	875	645	1230	910	M24 X 2	525	390	830	610	1150	845
1" - 12	370	275	955	705	1350	995	M30 X 3.5	960	705	1510	1120	2100	1550
1-1/8" - 7	480	355	1080	795	1750	1290	M30 X 2	1060	785	1680	1240	2320	1710
1-1/8" - 12	540	395	1210	890	1960	1440	M36 X 3.5	1730	1270	2650	1950	3660	2700
1-1/4" - 7	680	500	1520	1120	2460	1820	M36 X 2	1880	1380	2960	2190	4100	3220
1-1/4" - 12	750	555	1680	1240	2730	2010							
1-3/8" - 6	890	655	1990	1470	3230	2380							
1-3/8" - 12	1010	745	2270	1670	3680	2710							
1-1/2" - 6	1180	870	2640	1950	4290	3160							
1-1/2" - 12	1330	980	2970	2190	4820	3560							

¹ in-tpi = nominal thread diameter in inches-threads per inch
² N · m = newton-meters
³ ft-lb = foot pounds
⁴ mm x pitch = nominal thread diameter in millimeters x thread pitch

Torque tolerance + 0%, -15% of torquing values. Unless otherwise specified use torque values listed above.
 All locknuts or lubricated fasteners: Use 75% of torque value. (i.e. 1/2"-13 GR5 = 76 ft-lb; 75% of 76 or .75 x 76 = 57 ft-lb)

- This chart is an approximate estimate of torque values.
- Always tighten hardware to these values unless a different torque value or tightening procedure is listed for a specific application.
- Fasteners must always be replaced with the same grades as specified in the manual.
- Always use the proper tool for tightening hardware; SAE for SAE hardware and Metric for Metric hardware.
- Make sure that fastener threads are clean and that you properly start thread engagement.

Replacing the Blade

Frequently check rotor blades to make sure they are in good working condition and properly secured to the rotor.

Replace worn or damaged parts with new blades.

IMPORTANT:

- Make sure that the replacement of blade with other same weight. This will be a balance of rotor spinning.
- Recommend blade is the original factory accessories.

Blades replacement steps:

1. Remove locknut (#4), spring washer (#3), hex. head bolt (#1) from knife shaft location (#5).
2. Remove existing blade (#2)
3. Install a new blade.
4. Install blade with bolt, washers, spring washer and locknut, refer to **Figure 16**.
5. Tighten locknut with correct torque.
6. Lubricate points.

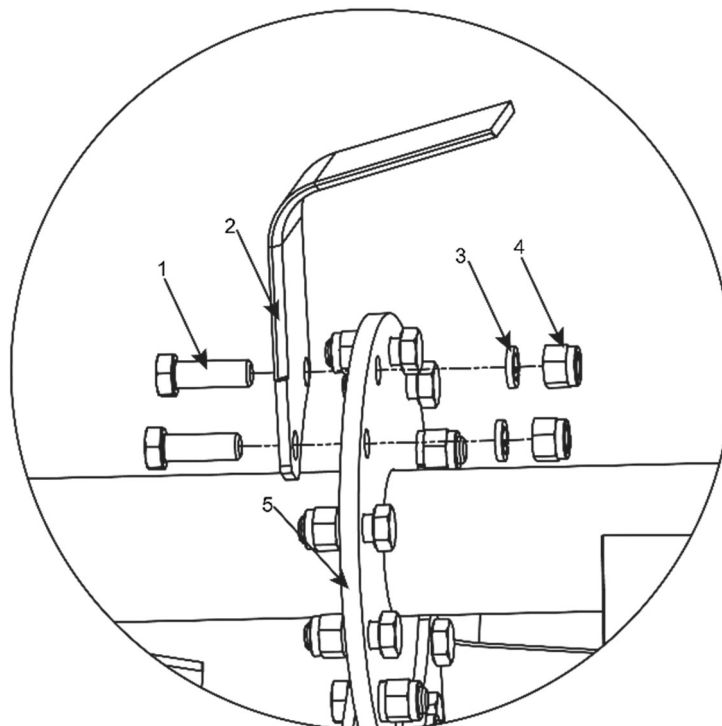

Figure 16

Note: If the images shown in the above figure are different from the machine, please check

[EXPLODED VIEW AND PARTS LIST](#).

STORAGE AND TRANSPORT

Storage

WARNING

- To avoid serious injury or death:
- Always disconnect driveline from the tractor and secure the implement in the up position with solid, non-concrete supports before servicing the underside. A person can become entangled in the drivetrain if the tractor is started and power take-off is engaged or crushed by an unsupported implement.

Clean, inspect, service, and make necessary repairs to the implement when storing it for long periods and at the end of the season. This will help to ensure the unit is ready for field use the next time you hook-up to it.

1. Clean off any dirt and grease that may have accumulated on the tiller and moving parts. Scrape off compacted dirt from bottom of tiller and then wash surface thoroughly with a garden hose. A coating of oil may also be applied to the areas where paint has been worn off from use to minimize oxidation.
2. Check tines and tine bolts for wear. Replace if necessary. Inspect tiller for loose, damaged or worn parts and adjust or replace as needed.
3. Inspect tiller for loose, damaged or worn parts and adjust or replace as needed.
4. Repaint parts where paint is worn or scratched to prevent rust.
5. A coating of oil may be applied to worn surfaces in lieu of painting to minimize oxidation.
6. Replace all damaged or missing labels.
7. Lubricate as noted in "[Lubrication Parts](#)".
8. Store tiller on a level surface in a clean, dry place. Inside storage will reduce maintenance and make for a longer tiller life.
9. Follow all "[Tractor Hook-up](#)" when disconnecting tractor from tiller.

Transport

WARNING

- Always disengage power take-off before raising tiller to transport position.
- When traveling on roadways, travel in such a way that other vehicles may pass you safely. Always use LED lights, clean reflectors, and a slow moving vehicle sign that is visible from the back to warn operators in other vehicles of your presence.
- Always comply with all federal, state, and local laws.

Before transport the implement, you should following the steps below:

1. When raising implement to transport position, be sure driveline does not contact tractor or implement. If needed, adjust and set tractor 3-point lift height to limit implement movement and to protect driveline.
 2. Be sure to reduce tractor ground speed when turning, leaving enough clearance so that the implement does not contact obstacles such as buildings, trees, fences, etc.
 3. Select a safe ground travel speed when transporting from one area to another. When traveling on roadways, transport in such a way that faster moving vehicles may pass safely.
 4. When traveling over rough or hilly terrain, shift tractor to a lower gear.
 5. Set park stand for transport.
- **IMPORTANT:** To prevent damaging the park stand, always store the stand in its transport position before moving the tiller.
 - Always adjust park stand up before traveling with tiller hitched to a tractor.
1. Raise tiller up until park stand (#3) is slightly above the ground.
 2. Shut tractor down without lowering the tiller before dismounting.
 3. Remove R pin (#1).
 4. Rotate park stand (#3) up as shown below.
 5. Reinsert L-Pin (#2) and R pin in upper holes.

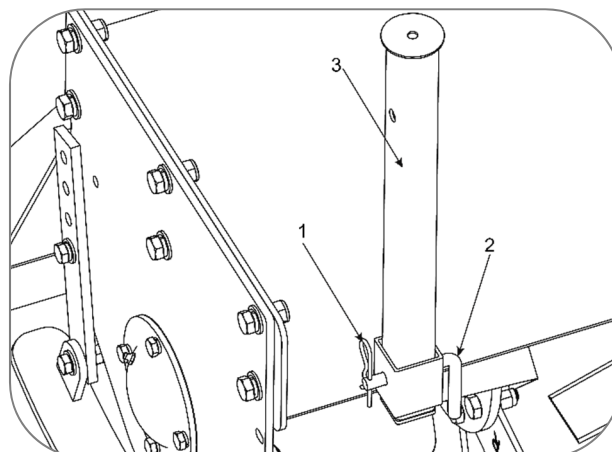

TROUBLESHOOTING

Listed general troubleshooting is the common malfunction that may or may not be application to the described in this manual. If you have any problem not covered in the list, please contact us for technical supporting.

General troubleshooting list:

Malfunction	Possible Cause	Solution
Implement makes intermittent clicking noise.	Tines are loose.	Tighten tines.
	Gearbox teeth damage	Replace a new one
Driveline vibrates.	Universal joint is worn.	Replace universal joint.
	Excessive trash is wrapped on rotor.	Remove trash.
	Implement is lifted too high.	Lower implement & readjust tractor lift stop.
Gearbox noise is noticeable and constant.	May be normal on new implement.	Allow time for break-in.
	Low oil level.	Add oil to the gearbox.
	Worn gears.	Replace gears in the gearbox.
	May be normal on new implement.	Allow time for break-in.
Oil leaking from gearbox.	Seals and/or gaskets are damaged.	Replace seals or gaskets in the gearbox.
	Gearbox is overfilled.	Drain oil to proper level.
Oil leaking from gear case.	Seals and/or gaskets are damaged.	Replace seals or gaskets in the gear case.
	Gear case is overfilled.	Drain oil to proper level.
Gear case noise is noticeable and constant.	May be normal on new implement.	Allow time for break-in.
	Worn gears.	Add oil to the gear case.
	Low oil level.	Replace gears in the gear case.
Rotor will not turn.	Power take-off is not engaged.	Engage power take-off.

Malfunction	Possible Cause	Solution
	Friction clutch is slipping.	Reduce tiller load or replace/service clutch.
Tillage depth insufficient.	Tiller is carried by tractor.	Lower tractor 3-point arms.
	Tractor has insufficient power.	Increase power take-off speed to 540 rpm.
	Skid shoes need adjusting.	Adjust skid shoes
	Tines are worn or bent.	Replace tines.
	Tines are incorrectly installed.	Check tine placement.
	Obstacles are entangled in tines and/or rotor.	Clear rotor and/or tines of obstacles.
Soil texture too coarse.	Leveling door is too high.	Lower leveling door.
	Power take-off speed is too slow.	Increase power take-off speed to 540 rpm.
	Ground speed is too fast.	Decrease ground speed.
Soil texture too fine.	Leveling door is too low.	Raise leveling door.
	Ground speed is too slow.	Increase ground speed.
Implement skips or leaves crop residue.	Tines are badly worn.	Replace worn tines.
	Friction clutch is slipping.	Reduce load or replace/service clutch.
	Ground speed is too fast for conditions.	Reduce ground speed.
Tines operating behind tractor tires show increased wear.	Tractor tires can compact soil causing tines that operate in the compacted soil to have increased wear.	Considered as normal wear. Replace worn tines.
Tines balling up with soil	Tines are worn or bent.	Replace tines.
	Tines are incorrectly installed.	Install tines correctly.
	Rear deflector is too low.	Raise rear deflector.
	Tractor speed is too fast.	Decrease tractor speed.
	Soil is too wet.	Wait until soil dries.

Malfunction	Possible Cause	Solution
Tiller bumping on ground	Obstacles are entangled in tines and/or rotor.	Clear rotor and/or tines.
	Tines are not installed correctly.	Install tines correctly.
	Tines are worn or bent.	Replace tines.
Tiller shaking	Ground is compacted and/or dry.	Irrigate soil and resume tilling.

EXPLODED VIEW AND PARTS LIST

MACHINE ASSEMBLY (ME-RT60-M)

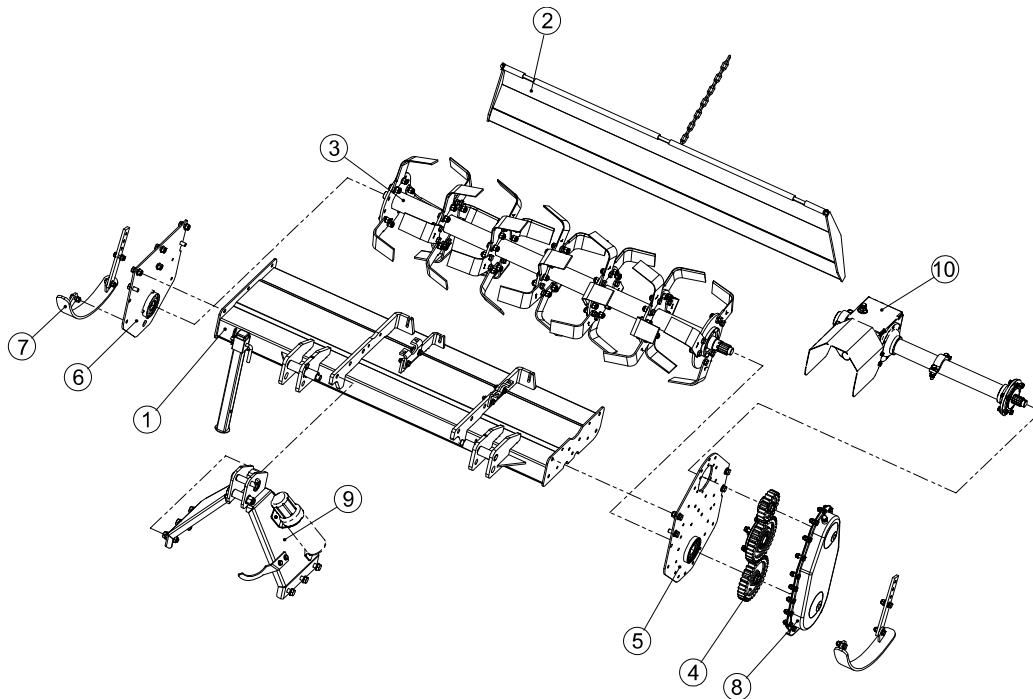

ME-RT60-M Parts name list:

POS.	COD.	Specification	Description	Qty.
1	2060105537	F06002A01000-000	Top cover	1
2	2060105516	F06002A05000-000	Rear deflector	1
3	2090000536	F06002A02000-000	Knife axle	1
4	2060105522	F06001A07000-000	Side driven system	1
5	2060105514	F06001A04000-000	Right panel	1
6	2060105513	F06001A03000-000	Left panel	1
7	2060105533	F06001A09000-000	Skid shoes	1
8	2060105523	F06001A08000-000	Protection cover	1
9	2060108780	F06001C10000-000	Hitch component	1
10	2060107012	F06002B06000-000	Gear box	1

MACHINE ASSEMBLY ME-RT60-M (CMR)

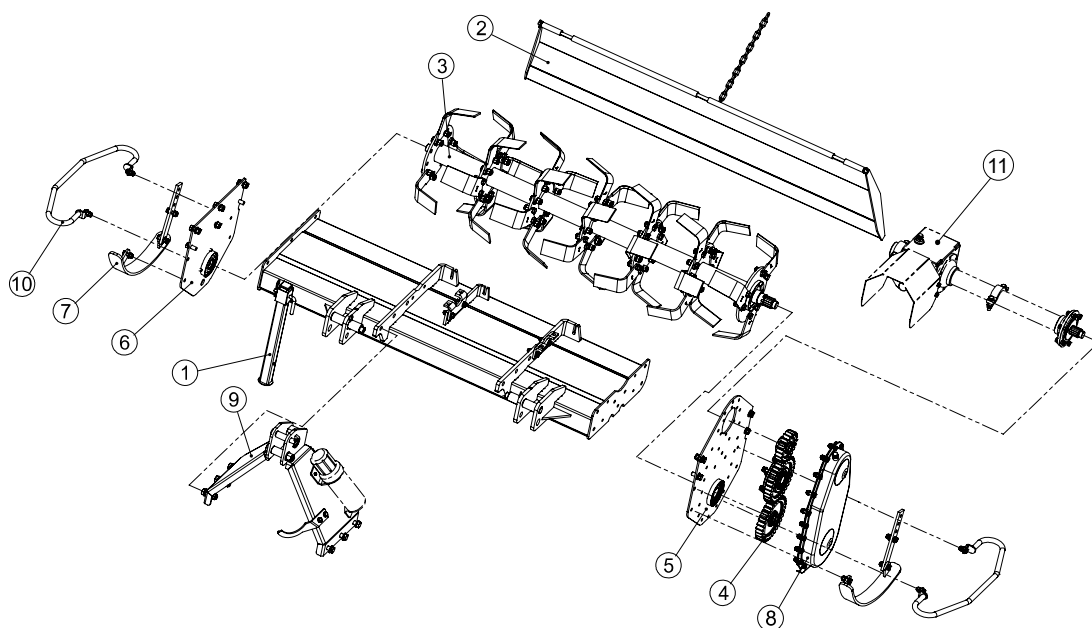

ME-RT60-M (CMR) Parts name list:

POS.	COD.	Specification	Description	Qty.
1	2060105537	F06002A01000-000	Top cover	1
2	2060105516	F06002A05000-000	Rear pane	1
3	2090000536	F06002A02000-000	Knife axle	1
4	2060105522	F06001A07000-000	Side driven system	1
5	2060105514	F06001A04000-000	Right panel	1
6	2060105513	F06001A03000-000	Left panel	1
7	2060105533	F06001A09000-000	Skid shoes	1
8	2060105523	F06001A08000-000	Protection cover	1
9	2060108780	F06001C10000-000	Hitch component	1
10	2060105543	F06001A11000-000	Side protection kit	1
11	2060107012	F06002B06000-000	Gear box	1

SIDE PROTECTION KIT ME-RT60-M (CMR)

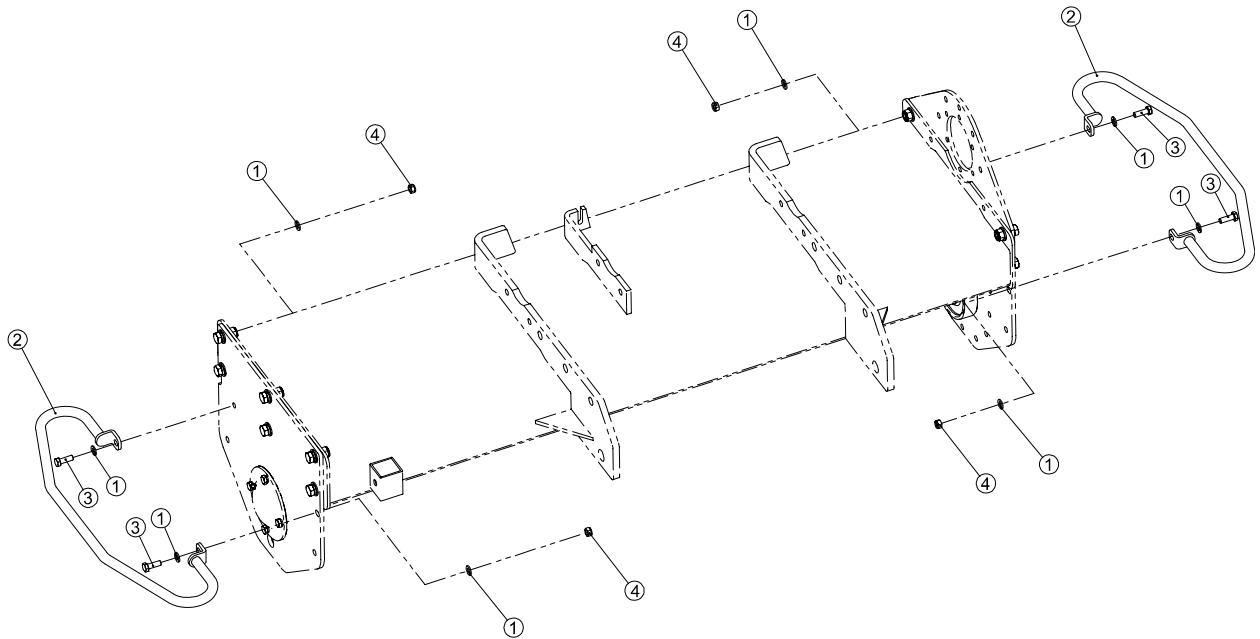

ME-RT60-M (CMR) Side protection kit parts name list:

POS.	COD.	Specification	Description	Qty.
1	3080100006	GB/T95-10-EP•Zn	Plain washer	8
2	2020001272	F06001A11100-000	Guard rail	2
3	3040100045	GB/T5783-M10×30- 8.8- EP•Zn	Full-thread hexagon bolts	4
4	3050500004	GB/T889.1-M10-8-	Locknut	4

MACHINE ASSEMBLY (ME-RT72-M)

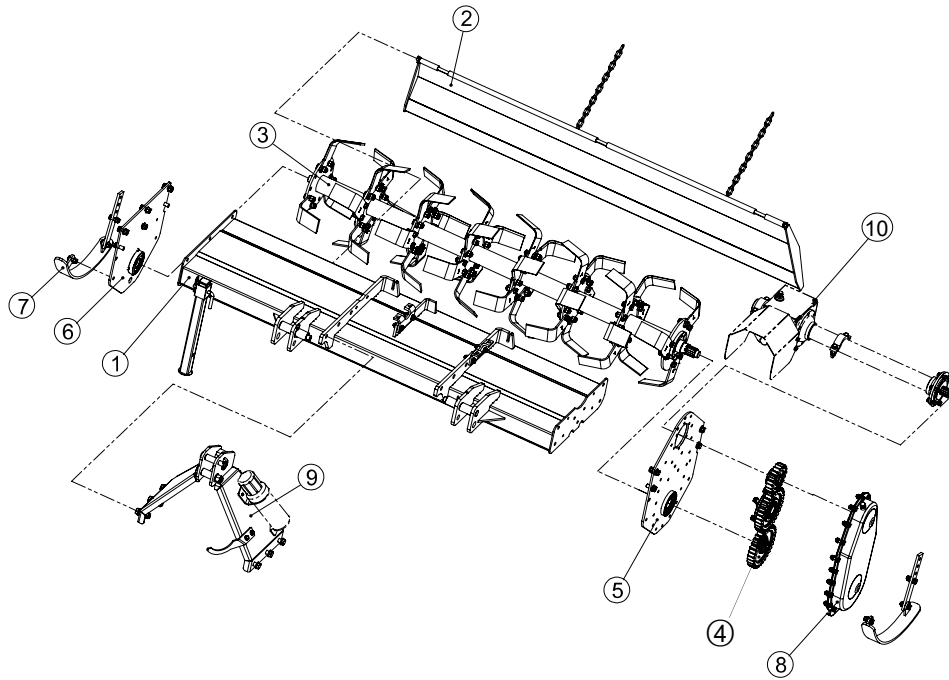

ME-RT72-M Parts name list:

POS.	COD.	Specification	Description	Qty.
1	2060105536	F06001A01000-000	Top cover	1
2	2060105515	F06001A05000-000	Rear deflector	1
3	2090000537	F06001A02000-000	Knife axle	1
4	2060105522	F06001A07000-000	Side driven system	1
5	2060105514	F06001A04000-000	Right Panel	1
6	2060105513	F06001A03000-000	Left Panel	1
7	2060105533	F06001A09000-000	Skid shoes	1
8	2060105523	F06001A08000-000	Protection cover	1
9	2060108780	F06001C10000-000	Hitch component	1
10	2060107011	F06001B06000-000	Gear box	1

MACHINE ASSEMBLY (ME-RT54-M/48-M/40-M/36-M)

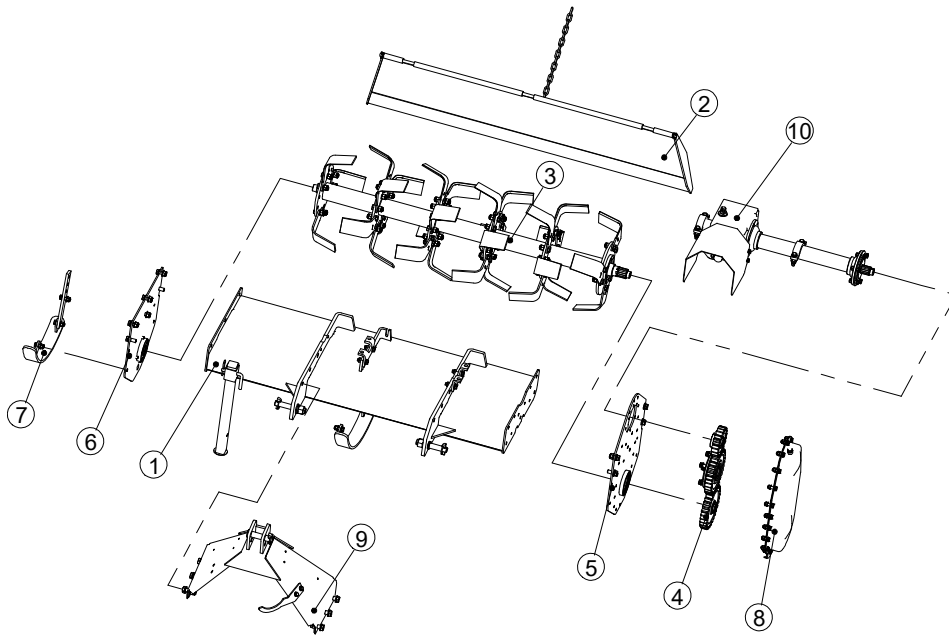

Machine (ME-RT54-M/48-M/40-M/36-M) description table:

COD.	Specification	Name
601060003	F06003A00000-000	ME-RT54-M Rotary tiller
601060004	F06004A00000-000	ME-RT48-M Rotary tiller
601060006	F06006A00000-000	ME-RT40-M Rotary tiller
601060007	F06007A00000-000	ME-RT36-M Rotary tiller

ME-RT54-M/48-M/40-M/36-M parts name list:

POS.	COD.	Specification	Description	36/Qty	54 /Qty	48/Qty	40/Qty
1	2060105542	F06007A01000-000	Top cover	1	-	-	-
1	2060105538	F06003A01000-000	Top cover	-	1	-	-
1	2060105539	F06004A01000-000	Top cover	-	-	1	-
1	2060105541	F06006A01000-000	Top cover	-	-	-	1
2	2060105521	F06007A05000-000	Rear deflector	1	-	-	-
2	2060105517	F06003A05000-000	Rear deflector	-	1	-	-
2	2060105518	F06004A05000-000	Rear deflector	-	-	1	-
2	2060105520	F06006A05000-000	Rear deflector	-	-	-	1
3	2090000531	F06007A02000-000	Knife shaft	1	-	-	-

POS.	COD.	Specification	Description	36/Qty	54 /Qty	48/Qty	40/Qty
3	2090000535	F06003A02000-000	Knife shaft	-	1	-	-
3	2090000534	F06004A02000-000	Knife shaft	-	-	1	-
3	2090000532	F06006A02000-000	Knife shaft	-	-	-	1
4	2060105522	F06001A07000-000	Gear driven system	1	1	1	1
5	2060105514	F06001A04000-000	Right panel	1	1	1	1
6	2060105513	F06001A03000-000	Left panel	1	1	1	1
7	2060105533	F06001A09000-000	Skid shoes	1	1	1	1
8	2060105523	F06001A08000-000	Protection cover	1	1	1	1
9	2060105534	F06002A10000-000	Hitch component	1	1	1	1
10	2060107013	F06003B06000-000	Gear box	-	1	-	-
10	2060107014	F06004B06000-000	Gear box	-	-	1	-
10	2060107017	F06006B06000-000	Gear box	-	-	-	1
10	2060107018	F06007B06000-000	Gear box	1	-	-	-

TOP COVER (ME-RT60-M)

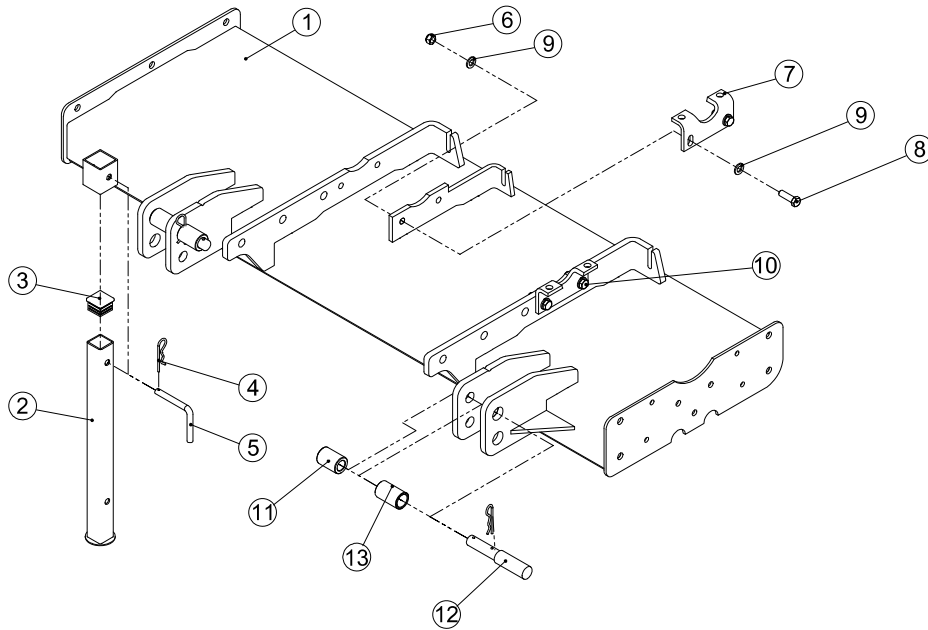

ME-RT60-M Top cover parts name list:

POS.	COD.	Specification	Description	Qty.
1	2020001245	F06002A01100-000	Panel hood	1
2	2020001234	F06001A01200-000	Support bar	1
3	3210200004	41×41	Square pipe plug	1
4	3120400008	Din11024-4-EP•Zn	R Pin	3
5	2010000017	G01001A16000-001	Rake pin	1
6	3050500007	GB/T889.1-M12-8-EP•Zn	Locknut	4
7	2000000608	F06001A01000-001	Lower support block	2
8	3040100071	GB/T5783-M12×40-8.8-EP•Zn	Full-thread hex. bolts	2
9	3080100007	GB/T95-12-EP•Zn	Plain washer	8
10	3040100072	GB/T5783-M12×45-8.8-EP•Zn	Full-thread hex. bolts	2
11	2010006336	F24026A01000-002	Hang lower suspension quick change sleeve pin	2
12	2010006675	F06001A01000-002	Hitch pin-lower	2
13	2010006674	F06001A01000-003	Hang Lower suspension quick change	2

TOP COVER (ME-RT72-M)

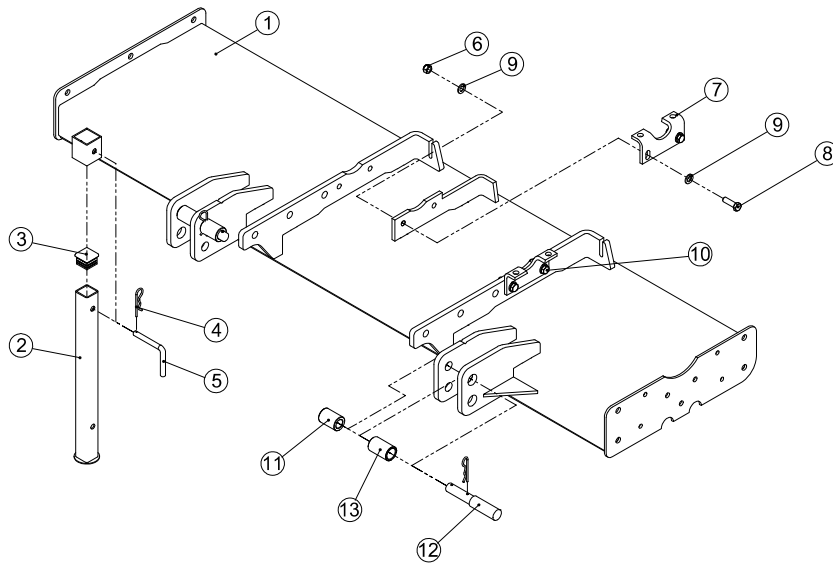

ME-RT72-M Top cover parts name list:

POS.	COD.	Specification	Description	Qty.
1	2020001246	F06001A01100-000	Panel hood	1
2	2020001234	F06001A01200-000	Support bar	1
3	3210200004	41×41	Square pipe plug	1
4	3120400008	Din11024-4-EP•Zn	R Pin	3
5	2010000017	G01001A16000-001	Rake pin	1
6	3050500007	GB/T889.1-M12-8-EP•Zn	Locknut	4
7	2000000608	F06001A01000-001	Lower support block	2
8	3040100071	GB/T5783-M12×40-8.8-EP•Zn	Full-thread hex. bolts	2
9	3080100007	GB/T95-12-EP•Zn	Plain washer	8
10	3040100072	GB/T5783-M12×45-8.8-EP•Zn	Full-thread hex. bolts	2
11	2010006336	F24026A01000-002	Hang Lower suspension quick change	2
12	2010006675	F06001A01000-002	Hitch pin-lower	2
13	2010006674	F06001A01000-003	Hang Lower suspension quick change	2

TOP COVER (ME-RT54-M /48-M/40-M/36-M)

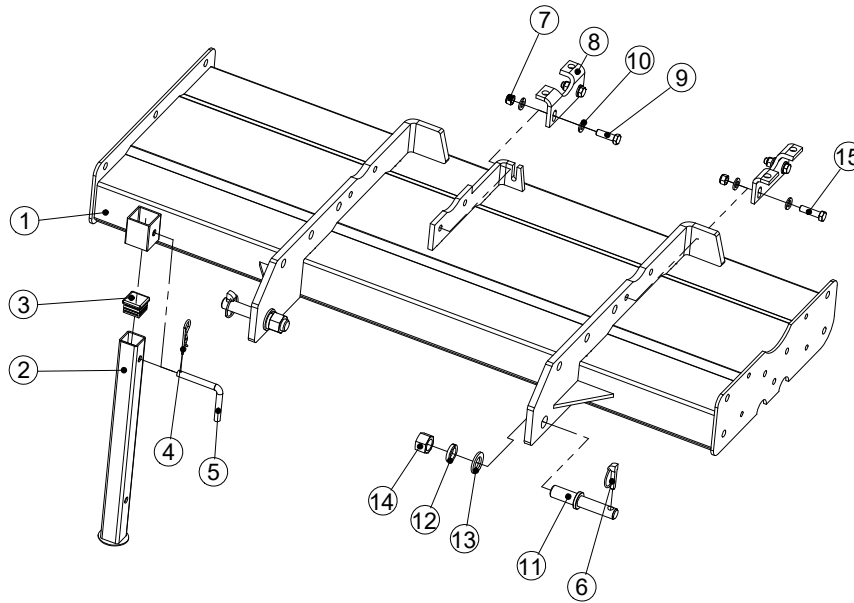

Top cover (ME-RT54-M /48-M/40-M/36-M) description table:

COD.	Specification	Name
2060105542	F06007A01000-000	ME-RT36-M Top cover
2060105541	F06006A01000-000	ME-RT40-M Top cover
2060105539	F06004A01000-000	ME-RT48-M Top cover
2060105538	F06003A01000-000	ME-RT54-M Top cover

Top cover (ME-RT54-M /48-M/40-M/36-M) parts name list:

POS.	COD.	Specification	Description	54/Qty	48/Qty	40/Qty	36/Qty
1	2020001244	F06003A01100-000	Panel hood	1	-	-	-
1	2020001243	F06004A01100-000	Panel hood	-	1	-	-
1	2020001242	F06005A01100-000	Panel hood	-	-	-	-
1	2020001241	F06006A01100-000	Panel hood	-	-	1	-
1	2020001240	F06007A01100-000	Panel hood	-	-	-	1
2	2020001234	F06001A01200-000	Support bar	1	1	1	1
3	3210200004	41×41	Square pipe plug	1	1	1	1
4	3120400008	Din11024-4-EP•Zn	R Pin	1	1	1	1

POS.	COD.	Specification	Description	54/Qty	48/Qty	40/Qty	36/Qty
5	2010000017	G01001A16000-001	Rake pin	1	1	1	1
6	3120400007	GB/T4329-12-EP•Zn	Pin	2	2	2	2
7	3050500007	GB/T889.1-M12-8-EP•Zn	Locknut	4	4	4	4
8	2000000608	F06001A01000-001	Lower support block	2	2	2	2
9	3040100071	GB/T5783-M12×40	Full-thread hex. bolts	2	4	4	4
10	3080100007	GB/T95-12-EP•Zn	Plain washer	8	8	8	8
11	2010000232	G01009A12000-003	Hitch pin-lower	2	2	2	2
12	3080500015	GB/T93-24-EP•Zn	Spring washer	2	2	2	2
13	3080100013	GB/T95-24-EP•Zn	Plain washer	2	2	2	2
14	3050100014	GB/T41-M24-5-EP•Zn	Hex. nuts	2	2	2	2
15	3040100072	GB/T5783-M12×45-8.8-EP•Zn	Full-thread hex. bolts	2	-	-	-

REAR DEFLECTOR (ME-RT72-M/60-M/54-M /48-M/40-M/36-M)

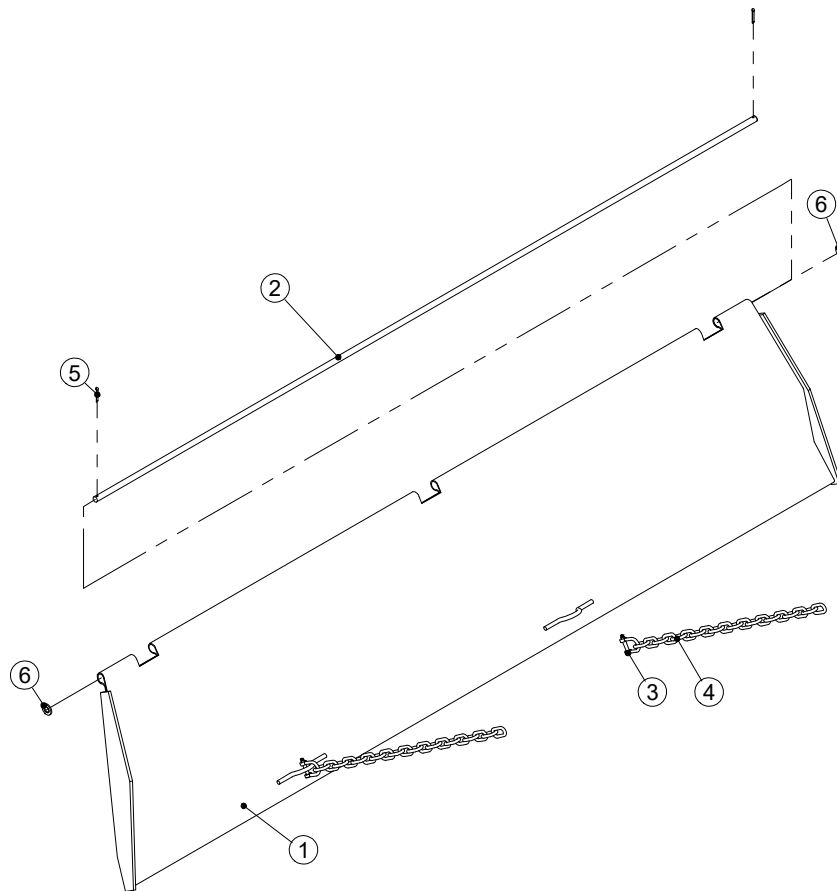

Rear deflector (ME-RT72-M/60-M/54-M /48-M/40-M/36-M) description table:

COD.	Specification	Name
2060105521	F06007A05000-000	ME-RT36-M Rear deflector
2060105520	F06006A05000-000	ME-RT40-M Rear deflector
2060105518	F06004A05000-000	ME-RT48-M Rear deflector
2060105517	F06003A05000-000	ME-RT54-M Rear deflector
2060105516	F06002A05000-000	ME-RT60-M Rear deflector
2060105515	F06001A05000-000	ME-RT72-M Rear deflector

Rear deflector parts name list:

POS.	COD.	Specification	Description	72/ Qty	60/ Qty	54/ Qty	48/ Qty	40/ Qty	36/ Qty
1	2020001264	F06001A05100-000	Baffle plate	1	-	-	-	-	-
1	2020001263	F06002A05100-000	Baffle plate	-	1	-	-	-	-
1	2020001262	F06003A05100-000	Baffle plate	-	-	1	-	-	-

POS.	COD.	Specification	Description	72/ Qty	60/ Qty	54/ Qty	48/ Qty	40/ Qty	36/ Qty
1	2020001261	F06004A05100-000	Baffle plate	-	-	-	1	-	-
1	2020001259	F06006A05100-000	Baffle plate	-	-	-	-	1	-
1	2020001258	F06007A05100-000	Baffle plate	-	-	-	-	-	1
2	2010000469	F06001A05000-001	Baffle plate shaft	1	-	-	-	-	-
2	2010000468	F06002A05000-001	Baffle plate shaft	-	1	-	-	-	-
2	2010000467	F06003A05000-001	Baffle plate shaft	-	-	1	-	-	-
2	2010000466	F06004A05000-001	Baffle plate shaft	-	-	-	1	-	-
2	2010000464	F06006A05000-001	Baffle plate shaft	-	-	-	-	1	-
2	2010000463	F06007A05000-001	Baffle plate shaft	-	-	-	-	-	1
3	3130600005	JB 8112-1999-8	D-ring	2	1	1	1	1	1
4	3130100016	8×32×28-20	Galvanized chain	2	1	1	1	1	1
5	3120100075	GB/T91-3.2×25	Split pin	2	2	2	2	2	2
6	3080100007	GB/T95-12-EP•Zn	Plain washer	2	2	2	2	2	2

KNIFE SHAFT (ME-RT72-M/60-M/54-M /48-M/40-M/36-M)

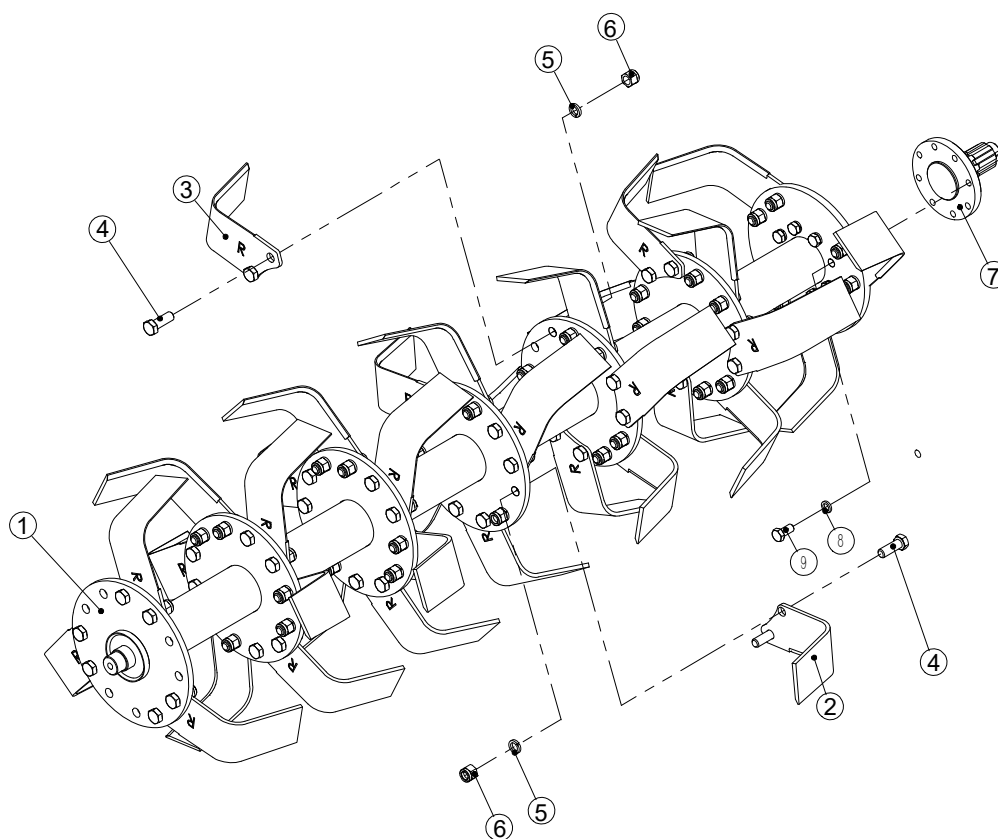

Knife shaft (ME-RT72-M/60-M/54-M /48-M/40-M/36-M) description table:

COD.	Specification	Name
2090000537	F06001A02000-000	ME-RT72-M Knife shaft
2090000536	F06002A02000-000	ME-RT60-M Knife shaft
2090000535	F06003A02000-000	ME-RT54-M Knife shaft
2090000534	F06004A02000-000	ME-RT48-M Knife shaft
2090000532	F06006A02000-000	ME-RT40-M Knife shaft
2090000531	F06007A02000-000	ME-RT36-M Knife shaft

Knife shaft parts name list:

POS.	COD.	Specification	Description	72/Qty	60/Qty	54/Qty	48/Qty	40/Qty	36/Qty
1	2020001256	F06002A02100-000	Blade axle	-	1	-	-	-	-
1	2020001257	F06001A02100-000	Blade axle	1	-	-	-	-	-
1	2020001255	F06003A02100-000	Blade axle	-	-	1	-	-	-

POS.	COD.	Specification	Description	72/Qty	60/Qty	54/Qty	48/Qty	40/Qty	36/Qty
1	2020001254	F06004A02100-000	Blade axle	-	-	-	1	-	-
1	2020001252	F06006A02100-000	Blade axle	-	-	-	-	1	-
1	2020001251	F06007A02100-000	Blade axle	-	-	-	-	-	1
2	3220100037	MT04001	Blade	21	18	15	15	12	9
3	3220100038	MT04002	Blade	21	18	15	15	12	9
4	3040200024	GB/T5786- M14×1.5×40-8.8-O	Full-thread hex. bolts	84	72	60	60	48	36
5	3080500010	GB/T93-14-EP•Zn	Spring washer	84	72	60	60	48	36
6	3050600006	GB/T889.2- M14×1.5-8-EP•Zn	Locknut (fine pitch)	84	72	60	60	48	36
7	3150200029	F06001A02000-001	Shaft	1	1	1	1	1	1
8	3080500009	GB/T93-12-EP•Zn	Spring washer	8	8	8	8	8	8
9	3040100065	GB/T5783-M12×25- 8.8-EP•Zn	Full-thread hex. bolts	8	8	8	8	8	8

GEAR DRIVEN SYSTEM (ME-RT72-M/60-M/54-M /48-M/40-M/36-M)

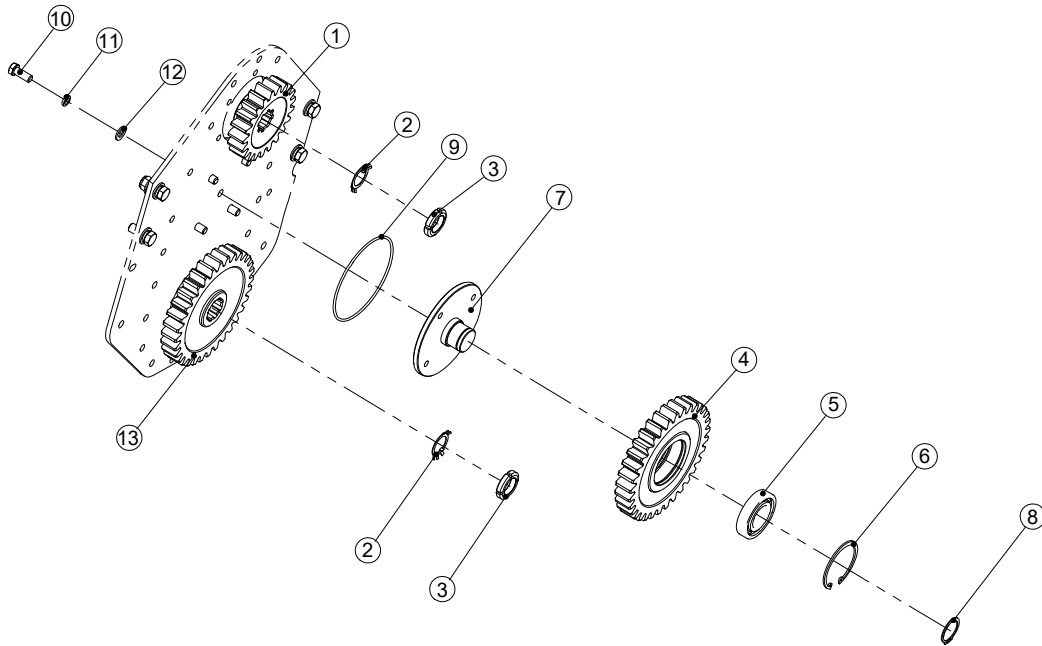

Gear driven system parts name list:

POS.	COD.	Specification	Description	Qty
1	3160600036	F06001A07000-002	Gear	1
2	3080800011	GB/T858-30×1	Tab washer	2
3	3050900011	GB/T812-M30×1.5	Round nut	2
4	3160600006	F06001A07000-001	Middle gear	1
5	3100100040	GB_T276-6208	Deep groove ball bearing	1
6	3080600046	GB/T893-80-A	Retaining rings for borP	1
7	3150200030	F06001A07000-004	Gear shaft	1
8	3080700026	GB/T894-40-A	Retaining rings for shaft	1
9	3170200008	GB3452.1-145×3.55-	O-Ring	1
10	3040100067	GB/T5783-M12×30-	Full-thread hex. bolts	5
11	3080500009	GB/T93-12-EP•Zn	Spring washer	5
12	3080100007	GB/T95-12-EP•Zn	Plain washer	5
13	3160600023	F06001A07000-003	Driven gear	1

GEAR BOX (ME-RT72-M/60-M/54-M /48-M/40-M/36-M)

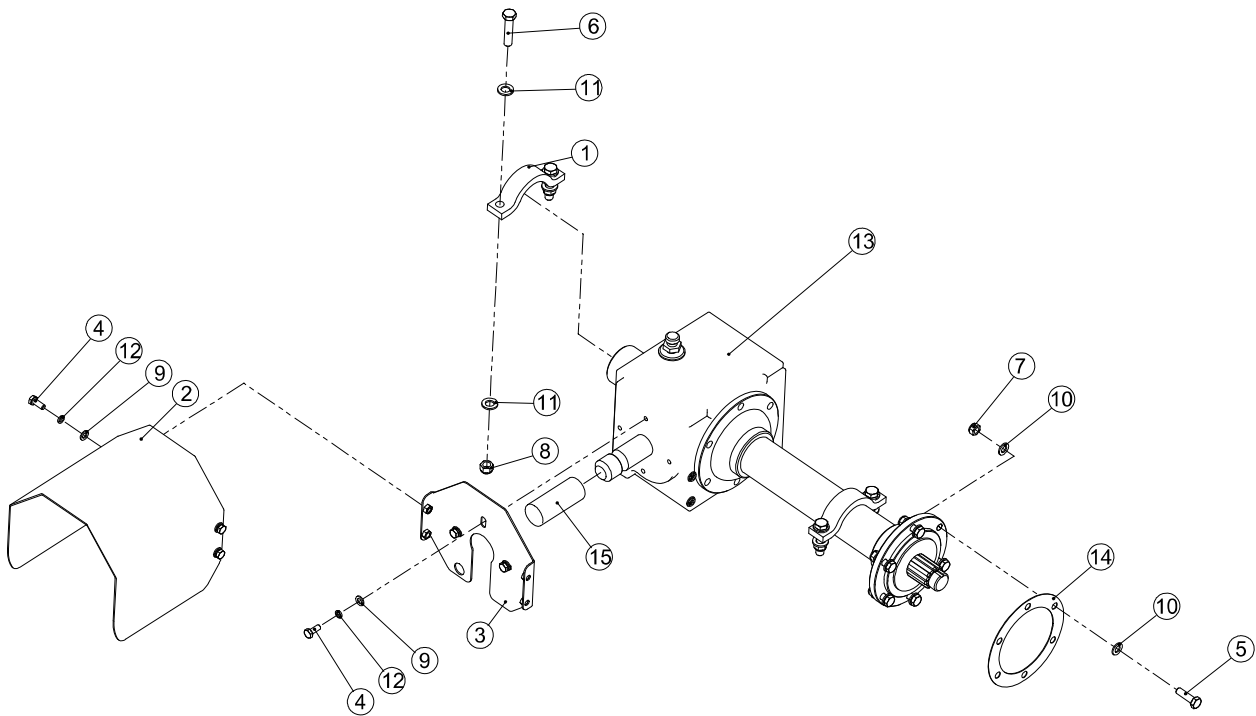

Gear box (ME-RT72-M/60-M/54-M /48-M/40-M/36-M) description table:

COD.	Specification	Name
2060105526	F06001A06000-000	ME-RT72-M Gear box
2060105527	F06002A06000-000	ME-RT60-M Gear box
2060105528	F06003A06000-000	ME-RT54-M Gear box
2060105529	F06004A06000-000	ME-RT48-M Gear box
2060105531	F06006A06000-000	ME-RT40-M Gear box
2060105532	F06007A06000-000	ME-RT36-M Gear box

Gearbox parts name list:

POS.	COD.	Specification	Description	72/ Qty	60/ Qty	54/ Qty	48/ Qty	40/ Qty	36/ Qty
1	2000000606	F06001A06000-001	Semicircular reverse	2	2	2	2	2	2
2	2000000611	F06001A06000-002	Guard plate	1	1	1	1	1	1
3	2020001416	F06001A06100-000	Cover seat plate	1	1	1	1	1	1
4	3040100022	GB/T5783-M8×20	Full-thread hex. bolts	7	7	7	7	7	7

POS.	COD.	Specification	Description	72/ Qty	60/ Qty	54/ Qty	48/ Qty	40/ Qty	36/ Qty
5	3040100046	GB/T5783- M10×35	Full-thread hex. bolts	6	6	6	6	6	6
6	3040100074	GB/T5783- M12×55	Full-thread hex. bolts	4	4	4	4	4	4
7	3050500004	GB/T889.1- M10-8	Locknut	6	6	6	6	6	6
8	3050500007	GB/T889.1- M12-8	Locknut	4	4	4	4	4	4
9	3080100004	GB/T95-8- EP•Zn	Plain washer	9	9	9	9	9	9
10	3080100006	GB/T95-10- EP•Zn	Plain washer	12	12	12	12	12	12
11	3080100007	GB/T95-12- EP•Zn	Plain washer	8	8	8	8	8	8
12	3080500007	GB/T93-8- EP•Zn	Spring washer	9	9	9	9	9	9
13	3160100708	KF-XH50A.011- Black	Gear box	1	-	-	-	-	-
13	3160100709	KF-XH50A.010- Black	Gear box	-	1	-	-	-	-
13	3160100710	KF-XH50A.008- Black	Gear box	-	-	1	1	-	-
13	3160100711	KF-XH50A.007- Black	Gear box	-	-	-	-	1	-
13	3160100712	KF-XH50A.006- Black	Gear box	-	-	-	-	-	1
14	3170500038	F06001A06000- 003	Paper washer	1	1	1	1	1	1
15	3210500603	Φ35×90	Rubber	1	1	1	1	1	1

RIGHT PANEL (ME-RT72-M/60-M/54-M /48-M/40-M/36-M)

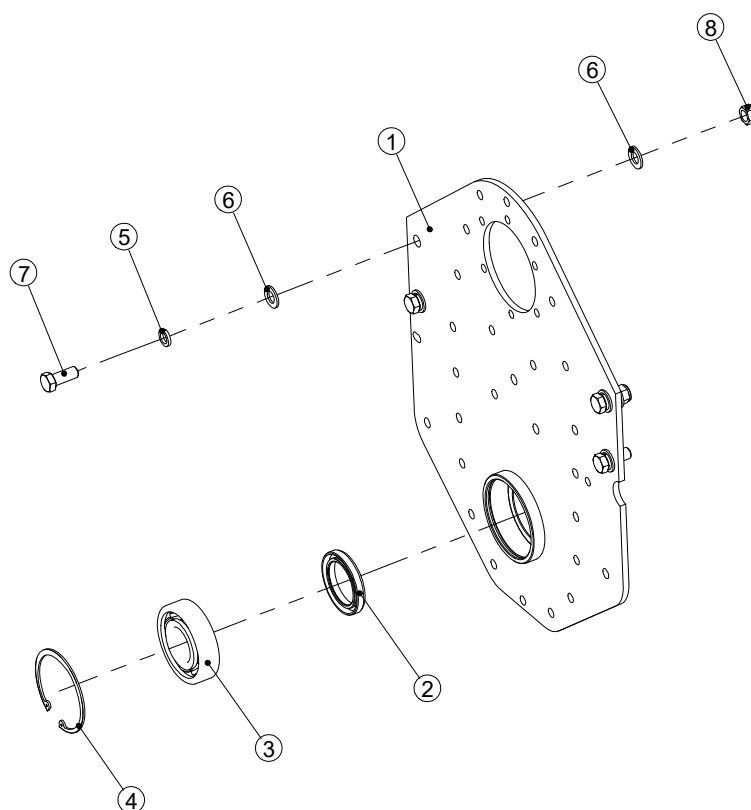

Right panel description table:

COD.	Specification	Description	Remark
2060105514	F06001A04000-000	Right panel	ME-RT72-M/60-M/54-M/48-M/40-M/36-M

Right panel parts name list:

POS.	COD.	Specification	Description	72/ Qty	60/ Qty	54/ Qty	48/ Qty	40/ Qty	36/ Qty
1	2020001232	F06001A04100-000	Side plate-R	1	1	1	1	1	1
2	3170100045	GB/T13871.1-FB-55×80×12-NBR	Shaft seal	1	1	1	1	1	1
3	3100100056	GB/T276-6309	Deep groove ball bearing	1	1	1	1	1	1
4	3080600054	GB/T893-100-A	Retaining rings for borP	1	1	1	1	1	1
5	3080500010	GB/T93-14-EP•Zn	Spring washer	4	4	4	4	4	4
6	3080100008	GB/T95-14-EP•Zn	Plain washer	6	6	6	6	6	6
7	3040100092	GB/T5783-M14×40-8.8-EP•Zn	Full-thread hex. bolts	4	4	4	4	4	4

POS.	COD.	Specification	Description	72/ Qty	60/ Qty	54/ Qty	48/ Qty	40/ Qty	36/ Qty
8	3050500008	GB/T889.1-M14-8-EP•Zn	Locknut	2	2	2	2	2	2

LEFT PANEL (ME-RT72-M/60-M/54-M /48-M/40-M/36-M)

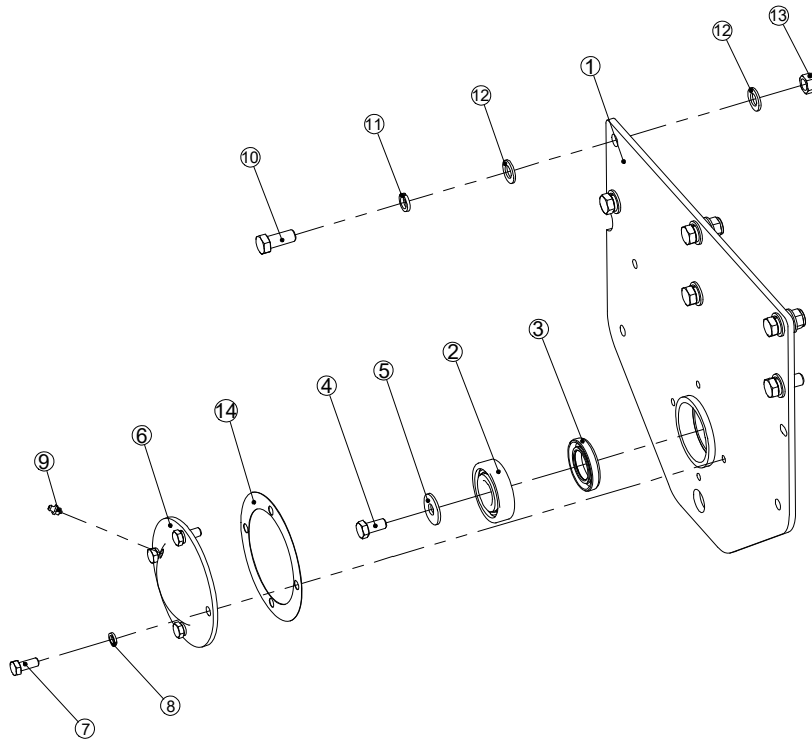

Left panel list:

COD.	Specification	Description	Remark
2060105513	F06001A03000-000	Left panel	ME-RT72-M/60-M/54-M/48-M/40-M/36-M

Left panel parts name list:

POS.	COD.	Specification	Description	72/ Qty	60/ Qty	54/ Qty	48/ Qty	40/ Qty	36/ Qty
1	2020001233	F06001A03100-000	Side plate-L	1	1	1	1	1	1
2	3100100048	GB/T276-6306	Deep groove ball bearing	1	1	1	1	1	1
3	3170100009	GB/T13871.1-FB-35×62×12-NBR	Shaft seal	1	1	1	1	1	1
4	3040100065	GB/T5783-M12×25-8.8-EP•Zn	Full-thread hex. bolts	1	1	1	1	1	1
5	3080200010	GB/T96.2-12-EP•Zn	Large plain washer	1	1	1	1	1	1
6	3220400007	F06001A03000-001	Bearing cover R	1	1	1	1	1	1
7	3040100043	GB/T5783-M10×25-8.8-EP•Zn	Full-thread hexagon bolts	4	4	4	4	4	4
8	3080500008	GB/T93-10-EP•Zn	Spring washer	4	4	4	4	4	4

POS.	COD.	Specification	Description	72/ Qty	60/ Qty	54/ Qty	48/ Qty	40/ Qty	36/ Qty
9	3170400003	JB/T7940.1-M8×1	Grease nipple	1	1	1	1	1	1
10	3040100092	GB/T5783-M14×40-8.8-EP•Zn	Full-thread hex. bolts	6	6	6	6	6	6
11	3080500010	GB/T93-14-EP•Zn	Spring washer	6	6	6	6	6	6
12	3080100008	GB/T95-14-EP•Zn	Plain washer	10	10	10	10	10	10
13	3050500008	GB/T889.1-M14-8-EP•Zn	Locknut	4	4	4	4	4	4
14	3170500037	F06001A03000-002	Paper pad	1	1	1	1	1	1

SKID SHOES (ME-RT72-M/60-M/54-M /48-M/40-M/36-M)

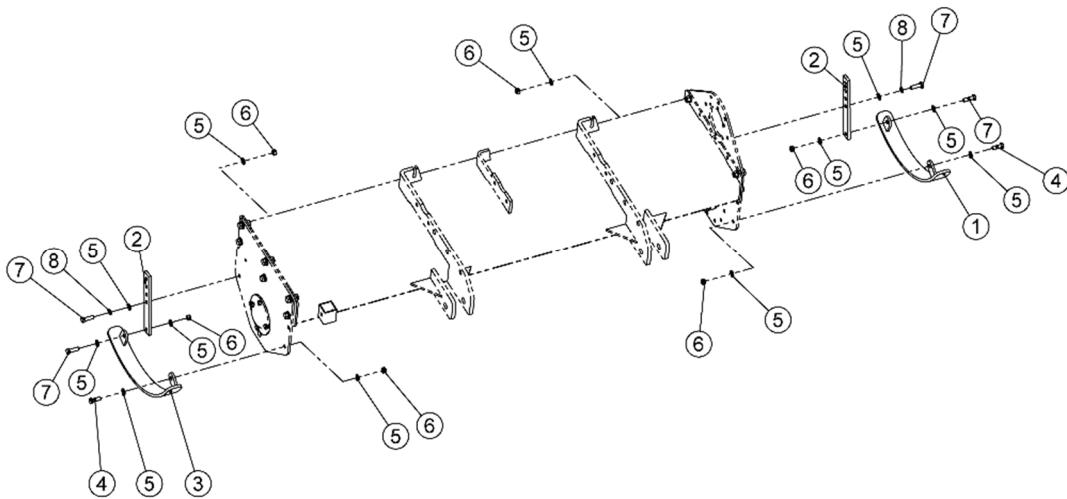

Skid shoes parts name list:

POS.	COD.	Specification	Description	Qty
1	2020001236	F06001A09100-000	Skating plate-L	1
2	2000000609	F06001A09000-001	Adjustable plate	2
3	2020001237	F06001A09200-000	Skating plate-R	1
4	3040100069	GB/T5783-M12×35-8.8-EP•Zn	Full-thread hex. bolts	2
5	3080100007	GB/T95-12-EP•Zn	Plain washer	12
6	3050500007	GB/T889.1-M12-8-EP•Zn	Locknut	6
7	3040100071	GB/T5783-M12×40-8.8-EP•Zn	Full-thread hex. bolts	4
8	3080500009	GB/T93-12-EP•Zn	Spring washer	2

PROTECTION PANEL (ME-RT72-M/60-M/54-M /48-M/40-M/36-M)

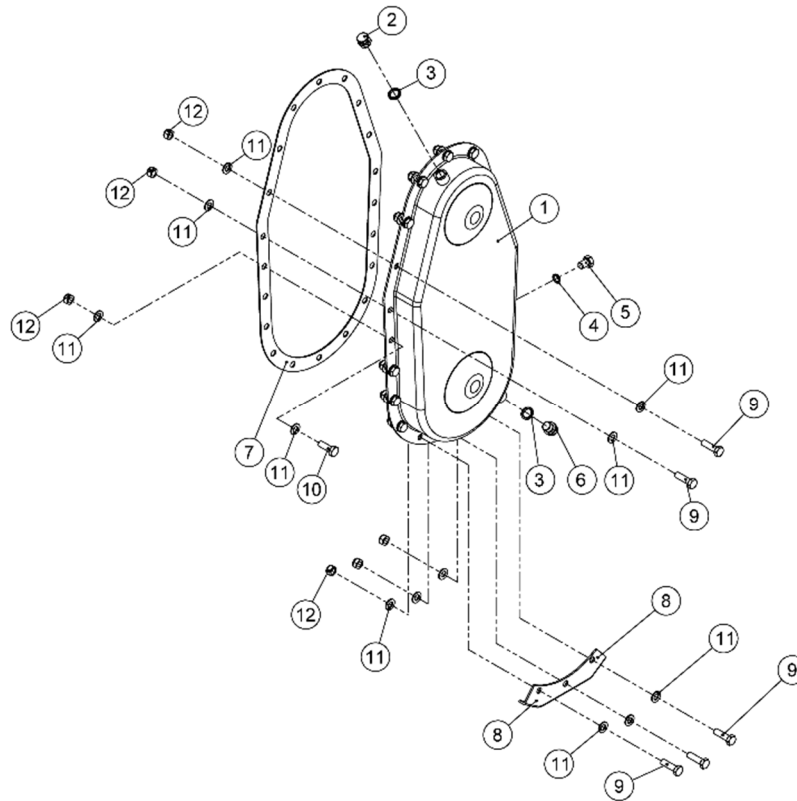

Protection panel parts name list:

POS.	COD.	Specification	Description	Qty
1	2020001235	F06001A08100-000	Gearbox cover	1
2	3170400013	QC-T412(JYG-82)-M16×1.5	Grease nipple	1
3	3170300023	BS/A-16.4×22×2.5-Q235	Combined sealing gaskets	2
4	3170300010	BS-12.4×16×2-Q235	Combined sealing gaskets	1
5	3040100063	GB/T5783-M12×16-8.8-EP•Zn	Full-thread hex. bolts	1
6	3040500006	JB/ZQ4770-M16×1.5	Outer hex. plug	1
7	3170500039	F06001A08000-002	Cork gasket	1
8	2000000610	F06001A08000-001	Guard plate	1
9	3040100046	GB/T5783-M10×35-8.8-EP•Zn	Full-thread hex. bolts	7
10	3040100045	GB/T5783-M10×30-8.8-EP•Zn	Full-thread hex. bolts	13
11	3080100006	GB/T95-10-EP•Zn	Plain washer	40
12	3050500004	GB/T889.1-M10-8-EP•Zn	Locknut	20

HITCH COMPONENT (ME-RT72-M/60-M)

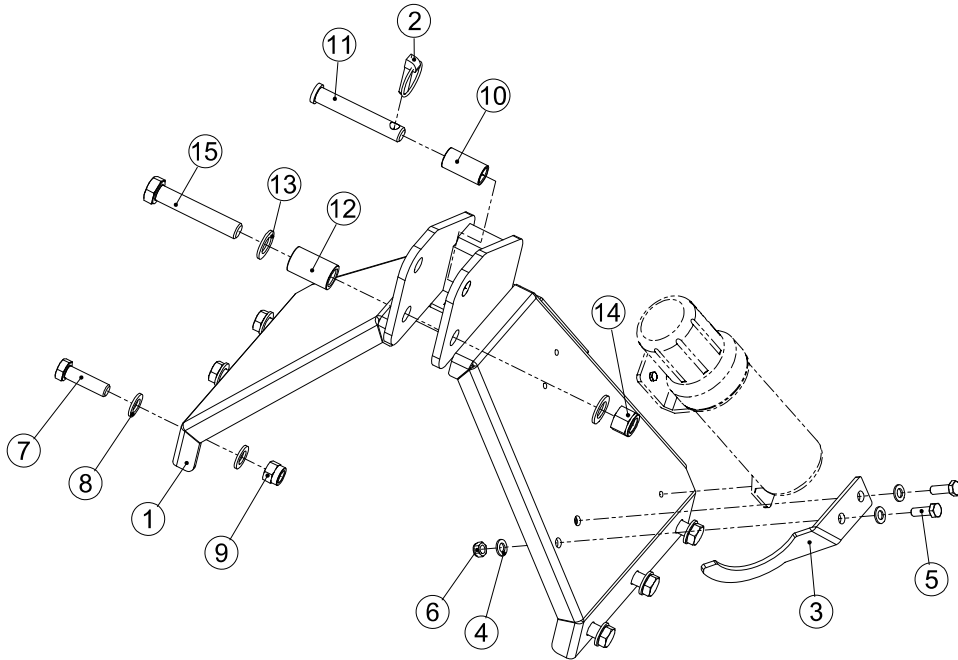

ME-RT72-M/60-M Hitch component parts name list:

POS.	COD.	Specification	Description	Qty
1	2020008841	F06001C10100-000	Hitch bracket	1
2	3120400007	GB/T4329-12-EP•Zn	Pin	1
3	2000000607	F06001A10000-002	Holding plate for PTO	1
4	3080100006	GB/T95-10-EP•Zn	Plain washer	4
5	3040100045	GB/T5783-M10×30-8.8-EP•Zn	Full-thread hex. bolts	2
6	3050500004	GB/T889.1-M10-8-EP•Zn	Locknut	2
7	3040100109	GB/T5783-M16×55-8.8-EP•Zn	Full-thread hex. bolts	6
8	3080100009	GB/T95-16-EP•Zn	Plain washer	12
9	3050500009	GB/T889.1-M16-8-EP•Zn	Locknut	6
10	2010005660	F24008A02000-004	Upper suspension sleeve	1
11	3120500007	MT95012	Hitch pin-Upper	1
12	2010005661	F24008A02000-003	Upper suspension sleeve	1
13	3080100011	GB/T95-20-EP•Zn	Flat washer	2
14	3050500011	GB/T889.1-M20-8-EP•Zn	Locknut	1
15	3040300074	GB/T5782-M20×110-8.8-EP•Zn	Hex. head bolts	1

HITCH COMPONENT (ME-RT54-M/48-M/40-M/36-M)

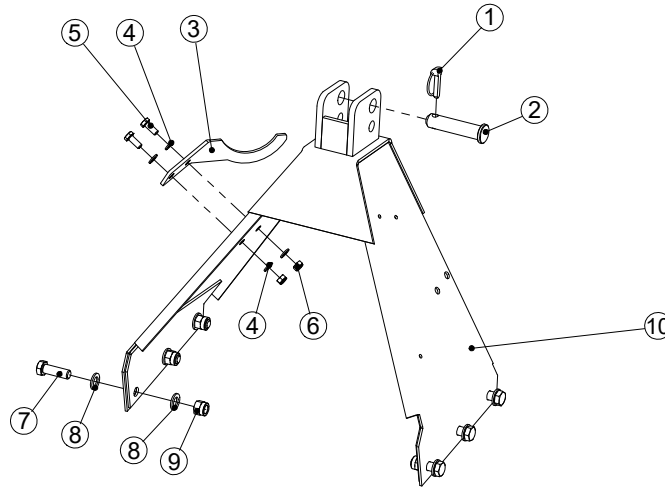

ME-RT54-M/48-M/40-M/36-M Hitch component parts name list:

POS.	COD.	Specification	Description	54/ Qty	48/ Qty	40/ Qty	36/ Qty
1	3120400007	GB/T4329-12-EP•Zn	Pin	1	1	1	1
2	2010000470	F06001A10000-001	Hitch pin-upper	1	1	1	1
3	2000000607	F06001A10000-002	Holding plate	1	1	1	1
4	3080100006	GB/T95-10-EP•Zn	Plain washer	4	4	4	4
5	3040100043	GB/T5783-M10×25	Hex. bolts	2	2	2	2
6	3050500004	GB/T889.1-M10-8	Locknut	2	2	2	2
7	3040100108	GB/T5783-M16×50	Hex. bolts	6	6	6	6
8	3080100009	GB/T95-16-EP•Zn	Plain washer	12	12	12	12
9	3050500009	GB/T889.1-M16-8	Locknut	6	6	6	6
10	2020001269	F06002A10100-000	Hitch bracket	1	1	1	1

WARRANTY

The Manufacturer warrants to the original purchaser that this product will be free from defects in material and workmanship beginning on the date of purchase by the end user according to the following schedule when used as intended and under normal service and conditions for personal use.

Overall Unit and Driveline: 24 months Parts and Labor

Gearbox: 24 months on all components.

Blades: Consumables materials

This Warranty is limited to the replacement of any defective part by the Manufacturer and the installation by the dealer of any such replacement part, and does not cover common wear items. The Manufacturer reserves the right to inspect any equipment or parts which are claimed to have been defective in material or workmanship.

This Warranty does not apply to any part or product which in Manufacturer's judgment shall have been misused or damaged by accident or lack of normal maintenance or care, or which has been repaired or altered in a way which adversely affects its performance or reliability, or which has been used for a purpose for which the product is not designed. Misuse also specifically includes failure to properly maintain oil levels, grease points, and driveline shafts.

Claims under this Warranty should be made to the dealer which originally sold the product and all warranty adjustments must be made through an authorized Manufacturer dealer. The Manufacturer reserves the right to make changes in materials or design of the product at any time without notice.

This Warranty shall not be interpreted to render Manufacturer liable for damages of any kind, direct, consequential, or contingent to property. Furthermore, the Manufacturer shall not be liable for damages resulting from any cause beyond its reasonable control. This Warranty does not extend to loss of crops, any expense or loss for labor, supplies, rental machinery or for any other reason.

No other warranty of any kind whatsoever, express or implied, is made with respect to this sale; and all implied warranties of merchantability and fitness for a particular purpose which exceed the obligations set forth in this written warranty are hereby disclaimed and excluded from this sale.

