

Flail Mower

OPERATOR'S MANUAL

ME-VFLMO54T

ME-VFLMO64T

ME-VFLMO72T

ME-VFLMO78T

ME-VFLMO86T

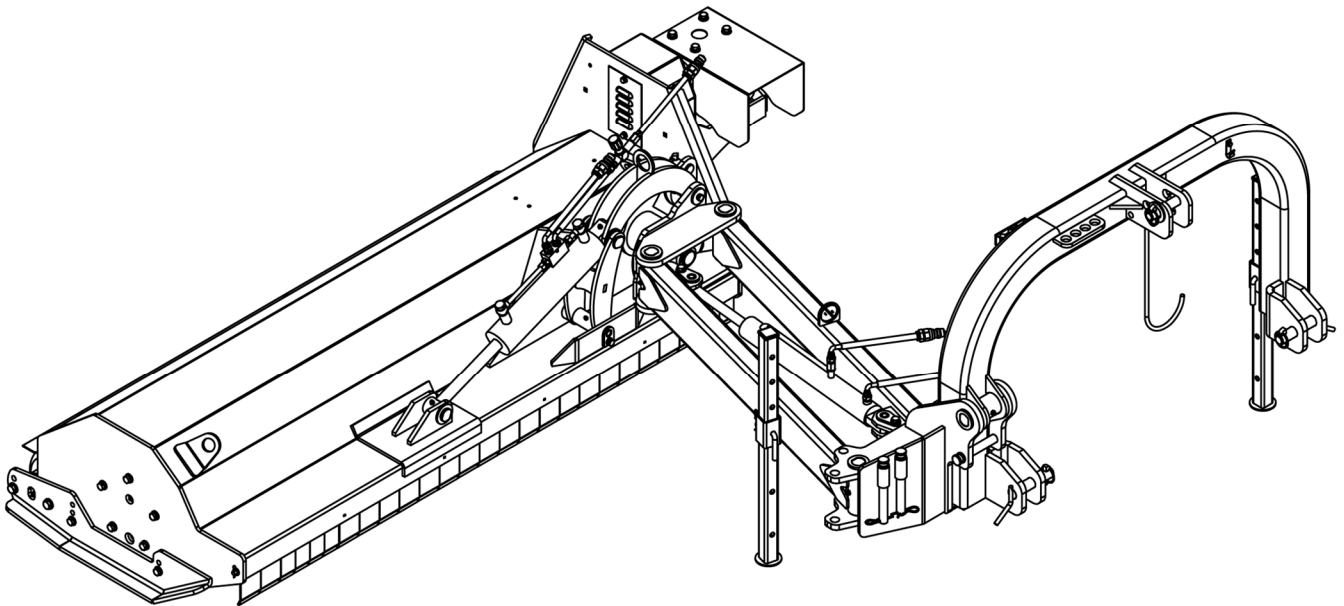

Please carefully read this manual and follow all the instructions. Failure to comply with the warnings and precautions may result in serious injury or death.

Content

CONTENT	1
SAFETY PRECAUTIONS	5
Safety First	5
Safety Alert Symbol	6
Safety for Children.....	6
Operation Safety	7
Tractor Shutdown Safety	7
Use A Safety Chain.....	7
Transport Safely	8
Avoid Crystalline Silica (Quartz) Dust	8
Avoid Contact Blades	9
Maintenance Safety	9
Preparation Before Maintenance	10
Personal Protective Equipment.....	10
Keep Riders Off Machinery.....	11
Safety Lights and Devices	11
Seat Belt and ROPS	11
Hydraulic System Safety	11
Handle Chemicals Properly	12
Tire Maintenance Safety	12
Storage and Disposal Safety	13

Storage Safety	13
Disposal Safety	13
Safety Labels	13
Labels Location	14
PRODUCT INTRODUCTION	15
Technical Data	17
Implement Identification	20
UNPACKING	21
ASSEMBLY & SET-UP	23
Assembling Swing Component	23
Connecting Hitch to Mower	23
Assembling Support Foot	24
Tractor Shutdown	24
Tractor Hook-up	25
Driveline Installation	26
Driveline Length Check	28
Maximum Extended Position	28
Customize Driveline	29
Driveline Interference Check	29
OPERATION	31
General Operating Instructions	31
Checklist before Operation	32
Levelling the Mower	33

Adjusting Lateral Position	33
Adjusting Incline Angle	34
Adjusting Roller/Skid Height	35
Starting the Machine.....	36
Inspection Before Starting	36
Operation the Machine	37
SERVICE AND MAINTENANCE	38
General Service.....	38
Gearbox Maintenance.....	38
PTO Shaft Maintenance	38
Lubrication Parts	39
Tightening Torque.....	41
Replacing the Blade.....	42
STORAGE AND TRANSPORT	43
Storage	43
Transport	44
TROUBLESHOOTING.....	45
EXPLODED VIEW AND PARTS LIST	47
WARRANTY.....	72

This page left blank intentionally.

SAFETY PRECAUTIONS

Listed below are common practices that may or may not be applicable to the products described in this manual.

Safety First

Careful operation is your best assurance against an accident.

Please be fully aware that you are responsible for the safe operation and maintenance of your implement. You must ensure that you and anyone else who is going to operate, maintain or work around the implement is familiar with the operating and maintenance procedures and related safe information contained in this manual. This manual is prepared to guide you through all essential operations related to this implement and alert you to all good safety practices that should be strictly followed.



Please constantly bear in mind that good safety practices not only protect you but also the people around you. Incorporate these practices an inseparable part into your safety program. Make sure that who operates this equipment is familiar with the recommended operating and maintenance procedures and follows all the safety precautions. Most accidents can be prevented. Do not risk injury of death by ignoring good safety practices.

- Thoroughly read and understand the “**Safety Labels**” section. Read all instructions noted on them.
- Do not operate the equipment while under the influence of drugs or alcohol, as they impair your ability to safely and properly operate the equipment.
- The operator should be familiar with all functions of the tractor and attached implement, and be able to handle emergencies quickly.
- Make sure all guards and shields appropriate for the operation are in place and secured before operating the implement.
- Keep all bystanders away from equipment and work area. Start tractor from the driver’s seat with hydraulic controls in neutral.
- Operate tractor and controls from the driver’s seat only.
- Never dismount from a moving tractor or leave tractor unattended with engine running.
- Do not allow anyone to stand between the implement and tractor while backing up to the implement.
- Keep hands, feet, and clothing away from power-driven parts.

- While transporting and operating equipment, watch out for objects overhead and along the sides such as fences, trees, buildings, wires, etc.
- Do not turn tractor so tight as to cause hitched implement to ride up on the tractor's rear wheel.
- Store implement in a safe and secure area where children normally do not play. When needed, secure implement against falling with support blocks.

Safety Alert Symbol

The SAFETY ALERT SYMBOL indicates there is a potential hazard to personal safety and extra precaution must be taken. When you see this symbol, be alert and carefully read the message that follows it. Hazard control, and accident prevention are dependent upon the awareness, concern, prudence, and proper training of personnel involved in the operation, transport, maintenance, and storage of equipment.

Be Aware of Signal Words

A signal word designates a degree or level of hazard seriousness. They are:

 **DANGER:** Indicates a hazardous situation that, if not avoided, will result in death or serious injury.

 **WARNING:** Indicates a hazardous situation that, if not avoided, could result in death or serious injury.

 **CAUTION:** Indicates a hazardous situation that, if not avoided, may result in minor or moderate injury.

Be Aware of Special Notices

Special notices are intended to point out important and helpful information that should be followed. They are:

ATTENTION: Indicates that equipment or property damage could result if instructions are not followed.

NOTE: Indicates supplementary explanations that will be helpful when using the equipment.

Safety for Children

Tragedy can occur if the operator is not alert to the presence of children, Children generally are attracted to implements and their work.

- Never assume children will remain where you last saw them.
- Keep children out of the work area and under the watchful eye of a responsible adult.

- Be alert and shut the implement and tractor down if children enter the work area.
- Never carry children on the tractor or implement. There is not a safe place for them to ride. They may fall off and be run over or interfere with the control of the power machine.
- Never allow children to operate the power machine, even under adult supervision.
- Never allow children to play on the power machine or implement.

Operation Safety

Use extra caution when backing up. Before the tractor starts to move, look down and behind to make sure the area is safety and clear.

Tractor Shutdown Safety

If engaged, disengage power take-off.

Park on solid, level ground and lower implement to ground or onto support blocks.

- Put tractor in park or set park brake.
- Turn off engine and remove ignition key to prevent unauthorized starting.
- Relieve all hydraulic pressure to auxiliary hydraulic lines.
- Wait for all components to stop before leaving operator's seat.
- Use steps, grab-handles and anti-slip surfaces when stepping on or off the tractor.
- If engaged, disengage power take-off.
- Park on solid, level ground and lower implement to ground or onto support blocks.
- Put tractor in park or set park brake.
- Turn off engine and remove ignition key to prevent unauthorized starting.
- Relieve all hydraulic pressure to auxiliary hydraulic lines.
- Wait for all components to stop before leaving operator's seat.
- Use steps, grab-handles and anti-slip surfaces when stepping on and off the tractor.

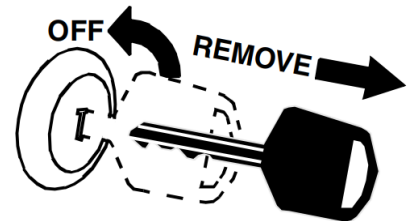

Use A Safety Chain

A safety chain will help control drawn machinery should it separate from the tractor drawbar.

Use a chain with the strength rating equal to or greater than the gross weight of the towed implement.

- Attach the chain to the tractor drawbar support or other specified anchor location. Allow only enough slack in the chain to permit turning.



- Always hitch the implement to the machine towing it. Do not use the safety chain to tow the implement.

Transport Safely

- Comply with federal, state, and local laws.
- Avoid contact with any overhead utility lines or electrically charged conductors.
- Engage park brake when stopped on an incline.
- Maximum transport speed for an implement is 30 km/h.
DO NOT EXCEED.
- Never travel at a speed which does not allow adequate control of steering and stopping. Some rough terrains require a slower speed. Sudden braking can cause a towed load to swerve and upset.
- Do not tow an implement that, when fully loaded, weights more than 1.5 times the weight of towing vehicle.

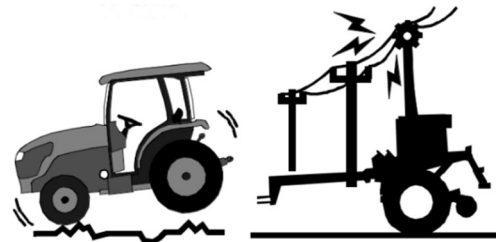

Avoid Crystalline Silica (Quartz) Dust

Because crystalline silica is a basic component of sand and granite, many activities at construction sites produce dust containing crystalline silica. Trenching, sawing, and boring of material containing crystalline silica can produce dust containing crystalline silica particles. This dust can cause serious injury to the lungs (silicosis). There are guidelines which should be followed if crystalline silica (quartz) is present in the dust.

- Be aware of and follow OSHA (or other local, State, or Federal) guidelines for exposure to airborne crystalline silica.
- Know the work operations where exposure to crystalline silica may occur.
- Participate in air monitoring or training programs offered by the employer.
- Be aware of and use optional equipment controls such as water sprays, local exhaust ventilation, and enclosed cabs with positive pressure air conditioning if the machine has such equipment. Otherwise respirators shall be worn.
- Where respirators are required, wear a respirator approved for protection against crystalline silica containing dust. Do not alter respirator in any way. Workers who use tight-fitting respirators can not have beards/ mustaches which interfere with the respirator seal to the face.
- If possible, change into disposable or washable work clothes at the work site; shower and change into clean clothing before leaving the work site.



- Do not eat, drink, use tobacco products, or apply cosmetics in areas where there is dust containing crystalline silica.
- Store food, drink, and personal belongings away from the work area.
- Wash hands and face before eating, drinking, smoking, or applying cosmetics after leaving the exposure area.

Avoid Contact Blades

Keep away from rotating blades to avoid death or serious injury from blade contact.

- Stay away and keep hands, feet and body away from rotating blades, drivelines and parts until all moving elements have stopped.
- Do not put hands or feet under mower hood.
- Stop rotating blades disengage PTO and wait for blade to stop rotating before raising mower hood or swings.
- Stop look and listen before approaching the mower to make sure all rotating motion has stopped.
- If a material blockage occurs in the inlet or discharge areas of the mower, shut down tractor engine, disengage the PTO and wait for all rotating motions to stop. Place the tractor in park position, engage the parking brake and remove the key before leaving the operator's seat. Clear the blockage before processing with mowing. Be sure to keep feet and hands clear of the mower blades. If you raise the mower or swing to access the blockage, engage the swing lock up latch and securely block up the mower before placing any parts of the body beneath the mower.

Maintenance Safety

- Good maintenance is your responsibility. Poor maintenance is an invitation to trouble.
- Follow good shop practices.
- Keep service area clean and dry.
- Be sure electrical outlets and tools are properly grounded.
- Use adequate light for the job at hand.
- Make sure there is plenty of ventilation. Never operate the engine of the tractor in a closed area. The exhaust gas may cause healthy problem.
- Before maintenance, shut off the tractor (See [Tractor Shutdown](#)).
- Allow equipment to cool before maintenance operation.
- Never work under the machine unless it is secured by a mechanical stand.

- Use personal protection devices such as safety goggles, hand gloves and hearing protectors, when performing any service or maintenance work. Use heavy gloves when handling blades.
- Only use original parts for service and maintenance.
- A fire extinguisher and first aid kit should be kept readily accessible while performing maintenance on this equipment.
- Periodically tighten all bolts, nuts and screws and check that all pins are properly installed to ensure unit is in a safe condition.
- Do not weld or torch on galvanized metal as it will release toxic fumes.
- Always make sure any material and waste products from the repair and maintenance of the implement are properly collected and disposed.
- Disconnect battery (If the implement has the battery) ground cable (-) before servicing or adjusting electrical systems or before welding on implement.
- Do not grease or oil implement while it is in operation.
- Do not work under any hydraulically supported equipment. It can settle, suddenly leak down, or be lowered accidentally. If it is necessary to work under the equipment, securely support it with stands or suitable blocking beforehand.
- When completing a maintenance or service function, make sure all safety shields and devices are installed before placing machine in service.

Preparation before Maintenance

- Be prepared if a fire starts.
- Keep a first aid kit and fire extinguisher handy.
- Keep emergency numbers for ambulance, hospital and fire department near the working area.

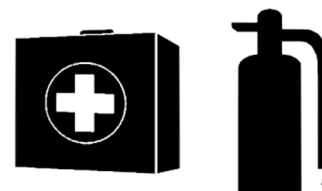

Personal Protective Equipment

- Wear protective clothing and equipment appropriate for the job such as safety shoes, safety glasses, hard hat, dust mask, and ear plugs.
- Clothing should fit snug without fringes and pull strings to avoid entanglement with moving parts.
- Prolonged exposure to loud noise can cause hearing impairment or hearing loss. Wear suitable hearing protection such as earmuffs or earplugs.
- Operating a machine safely requires the operator's full attention. Avoid wearing headphones while operating equipment.



Keep Riders Off Machinery

- Never carry riders on the tractor or implement.
- Riders obstruct operator's view and interfere with the control of the power machine.
- Riders can be struck by objects or thrown from the equipment.
- Never use the tractor or implement to lift or transport riders.



Safety Lights and Devices

- A slow moving power machine can create a hazard when driven on public roads. They are difficult to see, especially at night.
- Flashing warning lights and turn signals are recommended whenever driving on public roads.
- For tractors and other agriculture equipment, a Slow Moving Vehicle (SMV) sign is required when traveling on public roads.

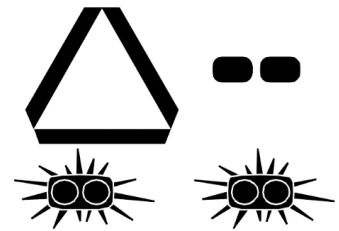

Seat Belt and ROPS

- We recommends the use of a CAB or roll-over-protective structures (ROPS) and seat belt in almost all power machines. Combination of a CAB or ROPS and seat belt will reduce the risk of serious injury or death if the power machine should be upset.
- If ROPS is in the locked-up position, fasten seat belt snugly and securely to help protect against serious injury or death from falling and machine overturn.



Hydraulic System Safety

- Escaping fluid under pressure will penetrate the skin or eyes causing serious injury.
- Relieve all residual pressure before disconnecting hydraulic lines or performing work on the hydraulic system.
- Make sure all hydraulic fluid connections are properly tightened/torqued and all hydraulic hoses and lines are in good condition before applying pressure to the system.
- Use a piece of paper or cardboard, NOT BODY PARTS, to check for suspected leaks.



- Wear proper hand and eye protection when searching for a high pressure hydraulic leak. Use a piece of wood or cardboard as a backstop instead of hands to isolate and identify a leak.
- DO NOT DELAY. If an accident occurs, seek immediate emergency medical care or gangrene may result.



Handle Chemicals Properly

- Protective clothing should be worn.
- Handle all chemicals with care.
- Follow instructions on container label.
- Agricultural chemicals can be dangerous. Improper use can seriously injure persons, animals, plants, soil, and property.
- Inhaling smoke from any type of chemical fire can be a serious health hazard.
- Store or dispose of unused chemicals as specified by the chemical manufacturer.



Tire Maintenance Safety

- Tire changing can be dangerous and must be performed by trained personnel using the correct tools and equipment.
- Always properly match the wheel size to the properly sized tire.
- Always maintain correct tire pressure. Do not inflate tires above recommended pressures shown in the Operator's Manual.
- When inflating tires, use a clip-on chuck and extension hose long enough to allow you to stand to one side and NOT in front of or over the tire assembly. Use a safety cage if available.
- Securely support the implement when changing a wheel.
- When removing and installing wheels, use wheel handling equipment adequate for the weight involved.
- Make sure wheel bolts have been tightened to the specified torque.



Storage and Disposal Safety

Storage Safety

1. Store the machine in an area away from human activity. Do keep the machine out of the children's reach. Do not permit children to play on or around the stored machine.
2. Store the machine in a dry, level area.
3. Clean grease and oil as required and protect it from the elements.

Disposal Safety

1. Improper disposal of oil or other waste may be hazardous to the environment.
2. When oil is emptied from the machine, it must be poured into a leak-proof container suitable for oil. It is not permissible to store oil in a container used for food or drink, in order to avoid the oil being consumed by mistake and causing serious injury. It is prohibited to spill oil on the ground, or pour it into a drain or anywhere leading to a water source.
3. Discarded oil, fuel, coolant, brake fluid, filters and batteries may not be thrown away or emptied in just any way. Contact your local authority for further information.

Safety Labels

Your implement comes equipped with all safety labels in place. They were designed to help you safely operate your implement. Read and follow their directions.

1. Keep all safety labels clean and legible.
2. Replace all damaged or missing labels.
3. When ordering new components make sure the correct safety labels are included in the request.
4. Refer to steps below for proper label placement.
 - a) Clean surface area where label is to be placed.
 - b) Spray soapy water onto the cleaned area.
 - c) Peel backing from label and press label firmly onto the surface.
 - d) Squeeze out air bubbles with edge of a card or with a similar type of straight edge.

Labels Location

Labels locations below are common practices of ME-VFLMO72 machine that may or may not be applicable to the products described in this manual.

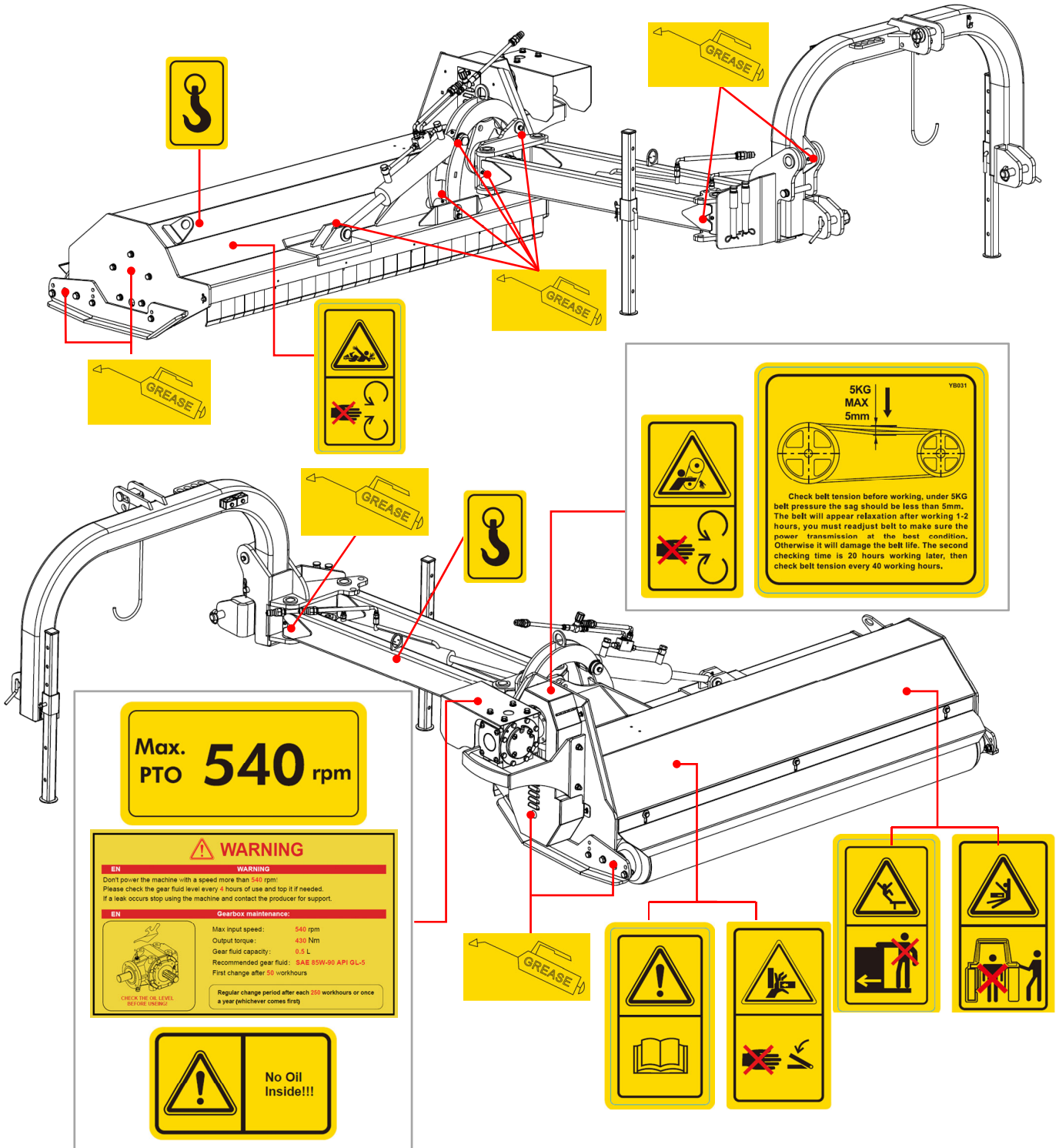

Figure 1

PRODUCT INTRODUCTION

Listed figure is common mower of ME-VFLMO72T that may be applicable to the products described in this manual.

See Figure 2

Mowers are designed and built to provide excellent cutting performance on gently sloping or slightly contoured right-of-ways, roadsides, ditches, farms, nurseries, and small fields of row crop debris, stalks, and residual agricultural growth. They have 10 models available according to the existence of rear cover named maintenance door: without the rear covers are ME-VFLMO54, ME-VFLMO64, ME-VFLMO72, ME-VFLMO78, ME-VFLMO86, and with the rear covers are ME-VFLMO54T, ME-VFLMO64T, ME-VFLMO72T, ME-VFLMO78T, ME-VFLMO86T, cutting angle, displacement, three points suspension. All models installed with fine cutting knives will perform extremely well cutting materials up to $\phi 4\text{cm}$, and also can be equipped with forged hammer knives and adjusted skid shoes to make them well suited for different materials.

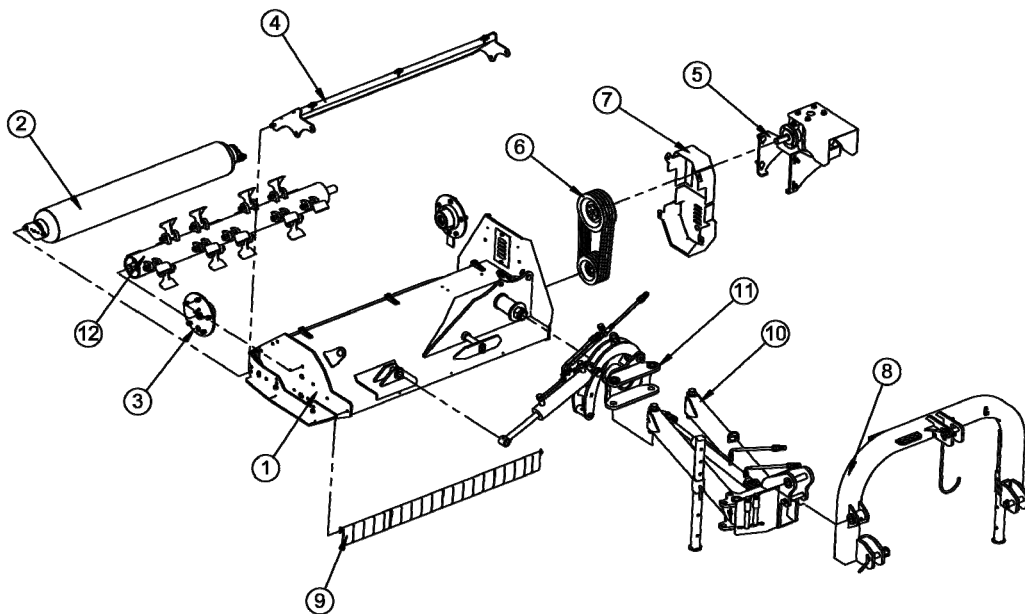

Figure 2

Main parts name and function list:

Item	Name	Functional Description
1	Hood assembly	Protecting people from harm during cutting procedure.
2	Roller assembly	As the mower moves forward, the rotating Roller rolls the grass close to the ground, and the cut material is then flattened over the field. Roller has three adjustable height from which it adapts to different grass heights, see Adjusting Roller/Skid Height .

Item	Name	Functional Description
3	Blade shaft bearing seat	Adjust the center between blade shaft and bearing seat automatically via self-aligning ball bearing when the mower moves to make sure the blade shaft runs normally.
4	Rear cover	Easy to maintenance the blades in the hood.
5	Gearbox drive	Connect the motor shaft to the gearbox. It is used to increase the output torque or change the speed (RPM) of the motor.
6	Side driveline	Transfer power generated by the engine to blade shaft and roller.
7	Side shield assembly	Protect the people or objects from harm of side driveline.
8	Hitch assembly	Hitch the implement to tractor via three-point hitch frame. Top and bottom hitch points float up and down which allows the mower to float over uneven terrain.
9	Protection component	Prevent the material from being thrown out.
10	Swing (lateral oil cylinder) assembly	Adjust the lateral position of the implement, see Adjusting Lateral Position .
11	Rollover (incline oil cylinder) assembly	Adjust the incline position of the implement, see Adjusting Incline Angle .
12	Ordinary axle + hammer blade	Cut the grass. There are two blade types (Hammer or Y-type blades) available.

Technical Data

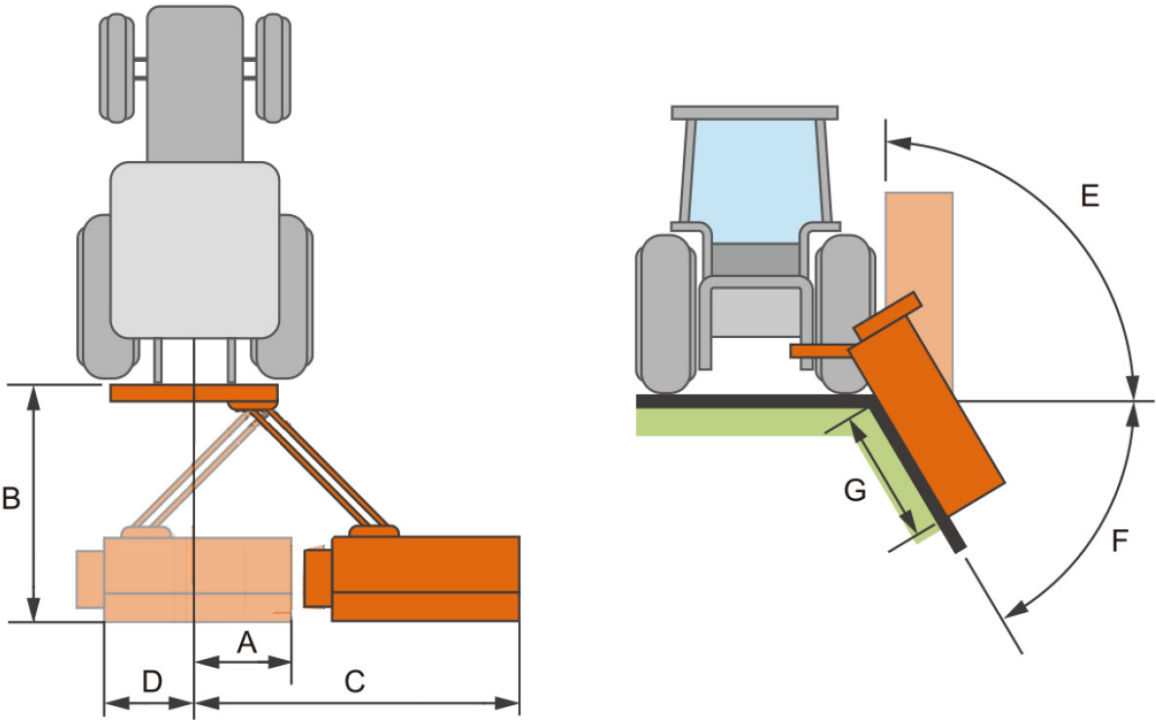

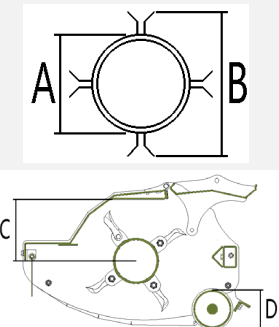









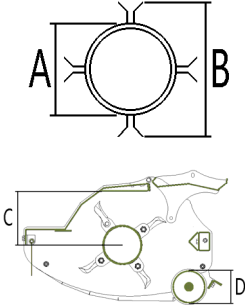









Figure 3

Implement specification table:

Model		ME-VFLMO54	ME-VFLMO64	ME-VFLMO72	ME-VFLMO78	ME-VFLMO86
A	mm	96.7	116.7	136.7	156.7	176.7
B		160.7	160.7	160.7	160.7	160.7
C		255.7	275.7	295.7	315.7	335.7
D		43.3				
E	°	93				
F		31				
G	cm	104.4	124.4	144.4	164.4	184.4
	mm	140	160	180	200	220
	RPM	2170				
	A(mm)	Φ127×8				

Model		ME-VFLMO54	ME-VFLMO64	ME-VFLMO72	ME-VFLMO78	ME-VFLMO86
	B(mm)	$\Phi 377/\Phi 372$ (Y)				
	C(mm)	224				
	D(mm)	$\Phi 194 \times 6$				
	Hood thickness					
	Side panel thickness (mm)	4/10	4/10	4/10	4/10	4/10
	V (m/s)	42.8				
Openable maintenance door	NO					
	HP	50				
	N	36	44	48	56	64
	N	18	22	24	28	32
	PTO (rpm)	540				
	CAT.	CAT. II				
	N	4				
 (with PTO shaft)	Kg	681	715	748	782	816
	HP	40-70	40-70	50-75	60-100	60-100

Model		ME-VFLMO54T	ME-VFLMO64T	ME-VFLMO72T	ME-VFLMO78T	ME-VFLMO86T
A	mm	96.7	116.7	136.7	156.7	176.7
B		160.7	160.7	160.7	160.7	160.7
C		255.7	275.7	295.7	315.7	335.7
D		43.3				
E	°	93				
F		31				
G	cm	104.4	124.4	144.4	164.4	184.4
	mm	140	160	180	200	220
	RPM	2170				
	A(mm)	Φ127×8				
	B(mm)	Φ377/Φ372 (Y)				
	C(mm)	224				
	D(mm)	Φ194×6				
	Hood thickness Side panel thickness (mm)	4/10	4/10	4/10	4/10	4/10
	V (m/s)	42.8				
	Openable maintenance door	YES				
	HP	50				
	N	36	44	48	56	64

Model		ME-VFLMO54T	ME-VFLMO64T	ME-VFLMO72T	ME-VFLMO78T	ME-VFLMO86T
	N	18	22	24	28	32
	PTO (rpm)	540				
	CAT.	CAT. II				
	N	4				
 (with PTO shaft)	Kg	681	715	748	782	816
	HP	40-70	40-70	50-75	60-100	60-100

Implement Identification

The identification nameplate is affixed to the frame of each implement. It contains: the Manufacturer, Type, Serial Number, Model Number, Weight. The nameplate (Shown in the below) is for reference only and is based on the real thing.

MATENG

TYPE <input style="width: 80%;" type="text"/>	YEAR <input style="width: 80%;" type="text"/>
TYPE <input style="width: 80%;" type="text"/>	ANNÉE <input style="width: 80%;" type="text"/>
SERIAL NO. <input style="width: 80%;" type="text"/>	WEIGHT <input style="width: 80%;" type="text"/>
N° DE SÉRIE <input style="width: 80%;" type="text"/>	POIDS <input style="width: 80%;" type="text"/>

Toll Free: 1-866-718-4746
 info@mateng.ca www.mateng.ca

UNPACKING

After unpacking, please check the components shown in **Figure 4**. If you have any problem, please contact us freely.

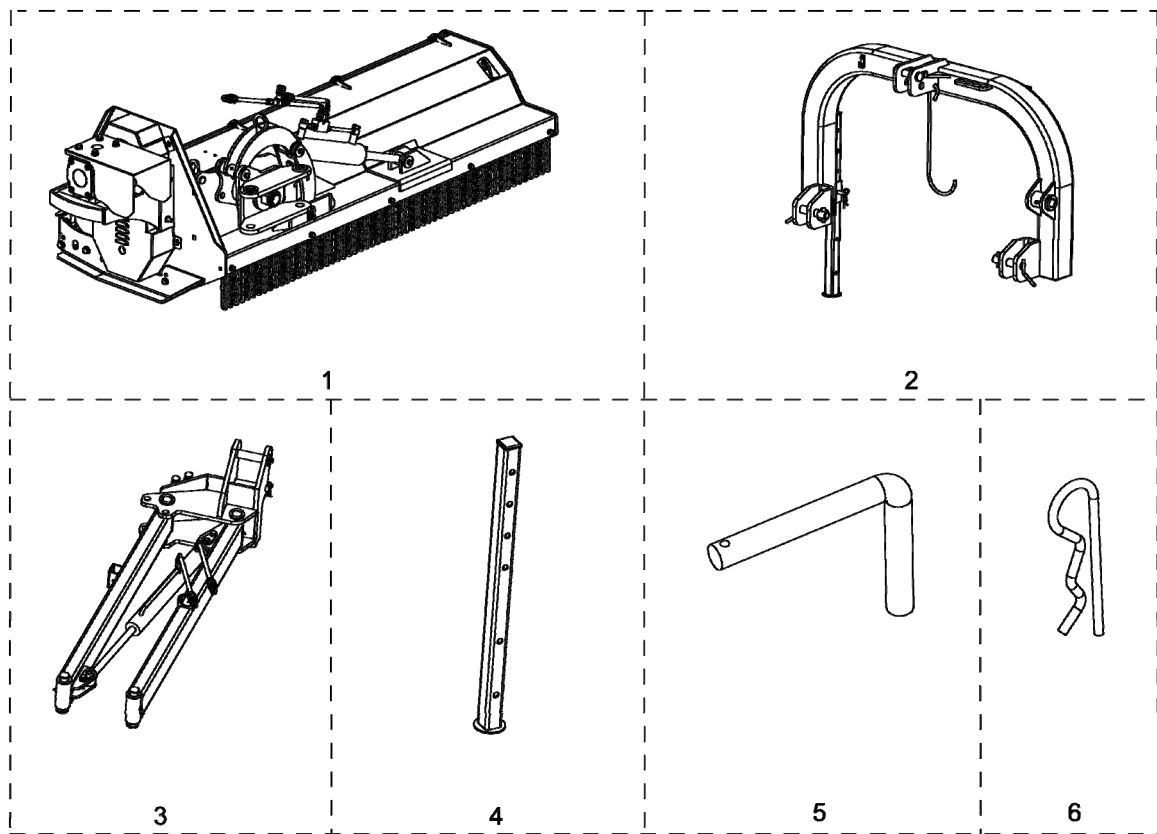

Figure 4

Unpacking parts description list:

Item	Specification	Description	Qty.	Packing
1	/	Host	1 pcs	Single pack
2	R02014A11000-000	Swing component	1 pcs	Single pack
3	R02014A09000-000	Hitch component	1 pcs	Single pack
4	R02001A09300-000	Support foot	1 pcs	Bale
5	G01001A16000-001	Foot pin	1 pcs	Bale
6	Din11024-4-EP•Zn	R pin	1 pcs	Bale

Tools for installation process list:

No.	Description	Specification	Conditions of Use	Qty.
1	Open end wrench	/	M24/M30 bolt fastening	2
2	Hex key	/	M24/M30 bolt fastening	1
3	Hammer	/	/	1
4	Torque wrench	10-220N.m	Measuring torque	1
5	Wind gun	1280t	Match the corresponding sleeve instead of the wrench to tighten the bolt	1

ASSEMBLY & SET-UP

Assembling Swing Component

To assemble the swing component:

1. Remove two swing shafts (2) located on the swing arms.
 2. Bolt the swing arms (3) to the inside of connector plate (1), using the right swing shaft, flat washer (4), spring plate (5), assemble as shown below and tighten the right bolt with locking nut (6).
 3. Use the left swing shaft, flat washer (4), spring plate (5), assemble as shown below and tighten the left bolt with locking nut (6).
- The head of the bolts should be on the top of the connector plate, and the washer, locking nut on the bottom side, see figure below.
4. Apply correct torque, for all fasteners.

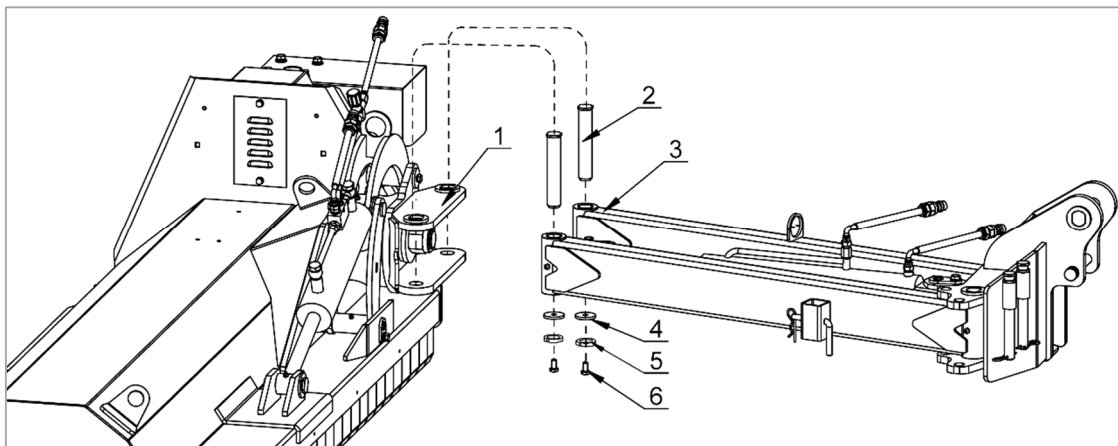

Figure 5

Connecting Hitch to Mower

To connect hitch to mower:

1. Remove the top shaft (1) and bottom shaft (2) that is used to locate hitch (8) to swing (7).
 2. Bolt the hitch component (8) to the inside of connector plate (7), using the top shaft (1), flat washer (2), spring washer (3), assemble as shown below and tighten them with locking nut (4).
- The head of the top shaft should be on the right side of the connector plate, and the flat washer, spring washer, locking nut on the left.
3. Insert the bottom shaft (5) into bottom hole of connector plate, assemble as shown below and tighten it with R pin (6).

- The head of bottom shaft (5) should be on the left side of the connector plate, and the R pin (6) on the left.

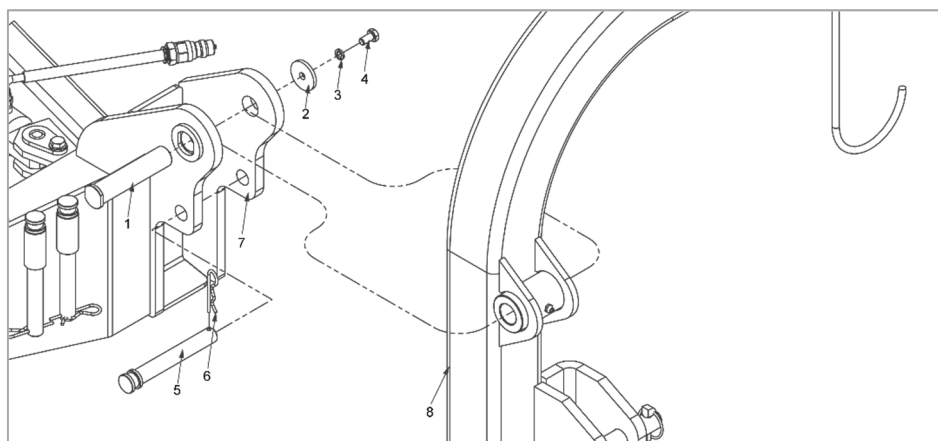

Figure 6

Assembling Support Foot

To assemble foot to left swing arm:

1. Bolt the foot (3) to the inside of fitting hole (2), using the foot pin (4), assemble as shown below and tighten it with R pin (1).

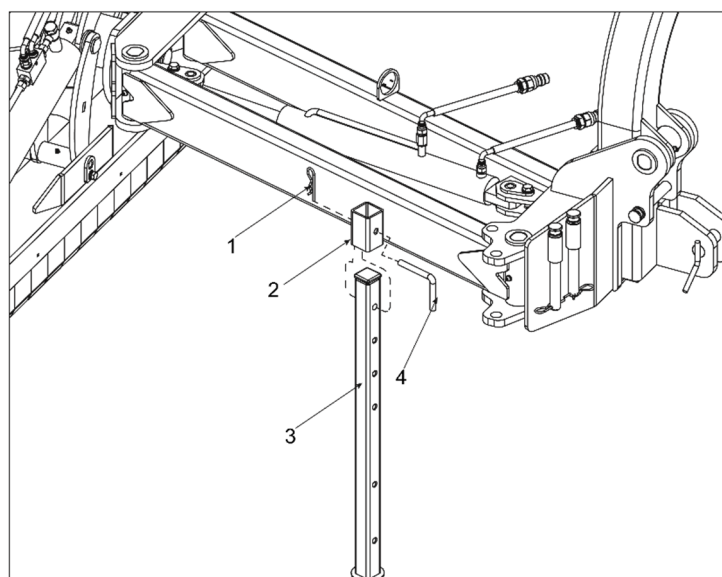

Figure 7

- The top four holes of foot are used for supporting implement when it parks, and the bottom two installation holes are for transportation.

Tractor Shutdown

The following are basic tractor shutdown procedures. Follow these procedures and any additional shutdown procedures provided in your tractor Operator's Manual before leaving the operator's seat.

1. Reduce engine speed and disengage power take-off if engaged.
2. Park tractor and implement on level, solid ground.
3. Lower implement to ground or onto non-concrete support blocks.

NOTE: Due to the over running clutch, the rotor blades will continue to spin after the driveline stops.

4. Put tractor in park or set park brake, turn off engine, and remove switch key to prevent unauthorized starting.
5. Relieve all hydraulic pressure to auxiliary hydraulic tubes.
6. Wait for all components to come to a complete stop before leaving the operator's seat.
7. Use steps, grab-handles and anti-slip surfaces when stepping on or off the tractor.

Tractor Hook-up

WARNING

- A crushing hazard exists while hooking-up and unhooking the implement. Keep people and animals away while approaching the implement or pulling away from the implement. Do not operate hydraulic controls while a person or an animal is nearby.
- Always follow "[Tractor Shutdown](#)" to power off.
- Tractor horsepower and hitch category should be within the required range. The lower 3-Point arms must be stabilized to prevent side-to-side movement.

Note:

- This mower is featured with a hitch design. It can be attached to the front of a tractor, some mower can be attached to both the front and rear of a tractor. Attaching a mower to the front of a tractor typically follows a similar process to attaching it to the rear, although there may be some differences based on the specific tractor. Make sure the mower is compatible with your tractor's front-end attachment system.
- There are one pair of extra hitch pins delivered at your disposal.
 1. Be certain tractor drawbar does not interfere. Move drawbar ahead or remove if required.
 2. Remove all hitch pins and linchpins.
 3. Attach tractor's top center link and lower arms with 3-point hitch correspondingly and secure with pins accordingly.
 4. The upper clevis has slots to compensate for uneven ground and to keep the roller in contact with the ground. After setting the work height, adjust the length of the top center link until hitch pin is close to the rear of the slot to ensure that the mower will work correctly.

5. The lower arms of a 3-point hitch for an offset/vertical mower has one end longer than the other to accommodate the offset design of the mower. This allows the mower to reach areas that a center-mounted mower cannot, such as along fence lines or ditches.

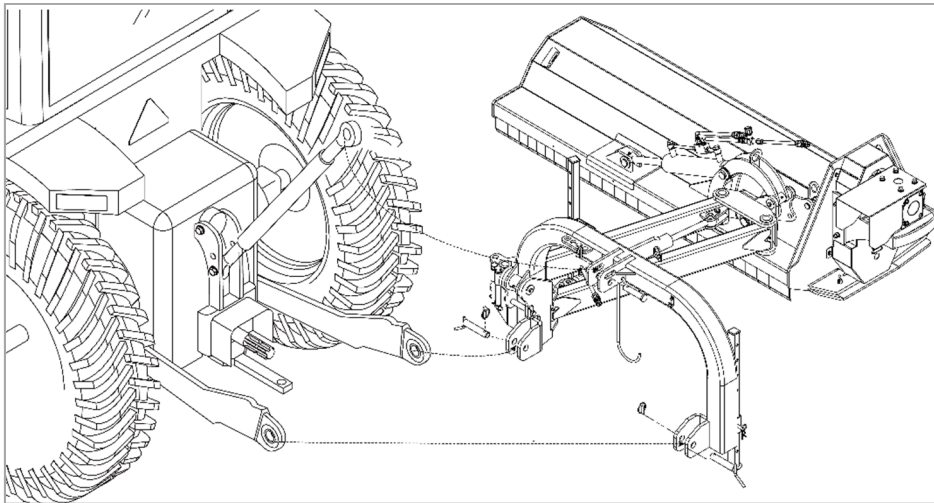

Figure 8

Driveline Installation

Listed below are common practices that may or may not be applicable to the products described in this manual.

Note: There are 3 types of PTO shafts available.

DANGER

- Do not engage tractor PTO while hooking-up and unhooking the prop shaft or stand near a rotating prop shaft. A person's body and/or clothing may get entangled to cause severe injury.
- Do not use a power take-off adapter. The adapter will increase strain on the tractor's power take-off shaft causing possible damage to shaft and driveline. It will also defeat the purpose of the tractor's power take-off shield.
- Make certain driveline yokes are securely fastened at each end. A loose yoke can work free allowing the driveline to rotate uncontrollably.

See Figure 9

Type A shaft has interchangeable ends for installation;

Type B shaft shall have the end where safety pin locates connected with the implement;

Type C shaft shall have end where the clutch locates connected with the implement.

Type D shaft shall have end where the wide angle joint locates connected with the tractor.

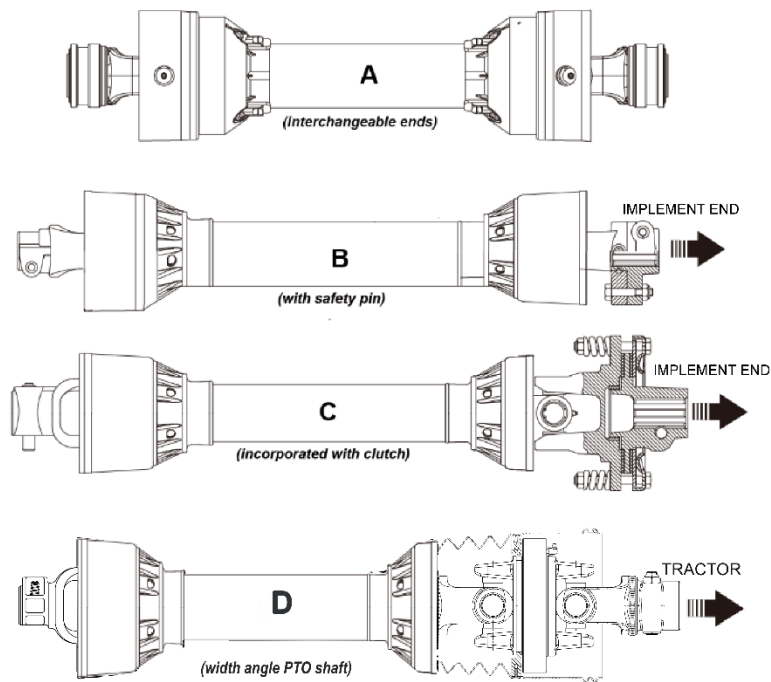

Figure 9

1. Park tractor on a level surface. Slowly engage tractor 3-Point lift lever to raise mowers until gearbox shaft is in line (level) with tractor PTO shaft.
2. Support mowers deck at this height with support jacks or blocks to keep mowers from drifting down.
3. Place gear selector in park, set park brake, shut tractor off, and remove switch key.
4. Slide inner yoke (implement end) of driveline onto the gearbox. Secure driveline with yoke locking device.
5. Slide outer yoke of driveline over the tractor PTO shaft. Secure driveline with yoke locking device.
6. If the driveline is too long and does not fit between tractor and gearbox, skip to [Customize Driveline](#) to shorten the driveline.
7. The driveline should now be moved back and forth to ensure secured connection at both ends. Reattach any end that is loose. Go to [Driveline Length Check](#) to ensure proper accommodation.
8. Hook driveline safety chain on the tractor end of driveline to the tractor. Re-latch safety chain to the driveline shield.
9. Hook driveline safety chain on the mowers end of driveline to the mowers frame. Re-latch safety chain to the driveline shield.

Driveline Length Check

Before operating the mower, ensure that the size of driveshaft is adequate. The driveshaft supplied with the machine has a standard length, therefore it may need an adaptation of the length, depending of the tractor which the mower is attached with.

Maximum compressed position.

The power take-off shaft and gearbox input shaft must be aligned and level with each other when checking driveline minimum length. A driveline that is too long can damage tractor and implement.

See Figure 10

Hold inner and outer drivelines parallel to each other as shown and measure distance **L1**:

1. If **L1** is less than 1" (2.5 cm), skip to [Customize Driveline](#) to shorten the driveline.
2. If **L1** is greater than or equal to 1" (2.5 cm), skip to [Maximum Extended Position](#) below.

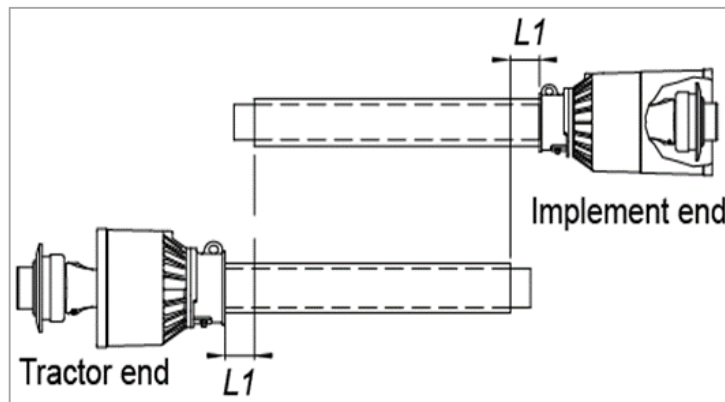

Figure 10

Maximum Extended Position

See Figure 11

The driveline maximum allowable length must, when fully extended, have a minimum overlap (**L2**) of profile tubes by not less than 1/3 the free length with both inner and outer profile tubes being of equal length.

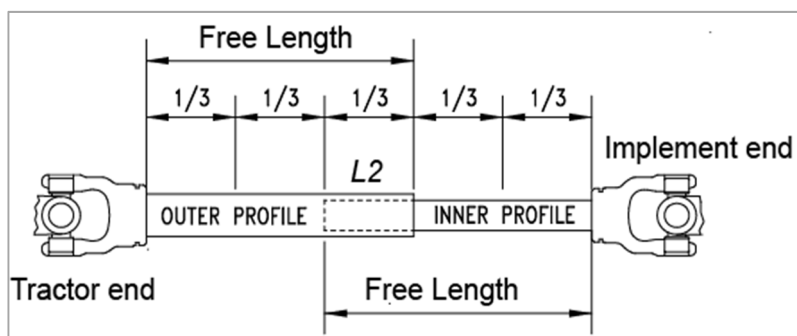

Figure 11

Customize Driveline

See *Figure 12*

1. Un-hook driveline from tractor PTO shaft and pull outer and inner drivelines apart.
2. Re-attach outer driveline to tractor PTO shaft. Pull on inner and outer drivelines to be sure universal joints are properly secured.
3. Hold inner and outer drivelines parallel to each other:
 - a. Measure 1" (2.5 cm) ("**L1**" dimension) back from outer driveline universal joint shield and make a mark at this location on the inner driveline shield.
 - b. Measure 1"(2.5 cm) ("**L1**" dimension) back from the inner driveline universal joint shield and make a mark at this location on the outer driveline shield.
4. Remove driveline from tractor and gearbox shafts.
5. Measure from end of inner shield to scribed mark ("X" dimension). Cut off inner shield at the mark. Cut same amount off the inner shaft ("X1" dimension).
6. Measure from end of outer shield to scribed mark ("Y" dimension). Cut off outer shield at the mark. Cut same amount off the outer shaft ("Y1" dimension).
7. Remove all burrs and cuttings.
8. Apply multi-purpose grease to the inside of the outer shaft and reassemble the driveline.

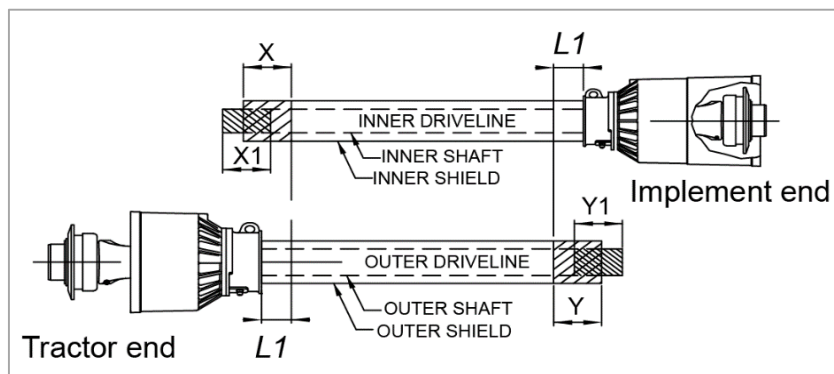

Figure 12

Driveline Interference Check

See *Figure 13*

Lowly engage tractor 3-Point control lever to lower mowers while checking for sufficient tongue clearance. Move tongue ahead, aside, or remove if required.

1. Raise and lower implement to find maximum extended driveline length. Check to make certain the driveline does not exceed the maximum allowable length and 25° up or down.
2. If needed, set tractor 3-Point lift height to keep driveline from exceeding the maximum allowable length and 25° up or down.

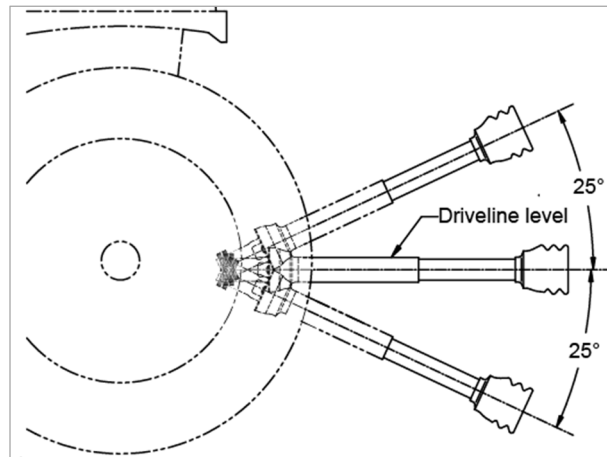

Figure 13

See Figure 14

Slowly and carefully fully extend lateral cylinder and then extend and retract incline cylinder to ensure the PTO shaft does not interfere with lateral joint.

When the mower is used in combination with certain tractors and in extreme conditions, PTO shaft may come into contact with the top of lateral joint. This may occur in the following conditions when the mower is at maximum lateral adjustment

- When the mower is inclined
- When the tractor lift is use

In these conditions, take particular care to prevent the movements of the driveline from causing the shaft itself to come into contact with the structure as the mower approaches its maximum permitted travel. Contact may cause severe damage to the driveline and the mower and is dangerous.

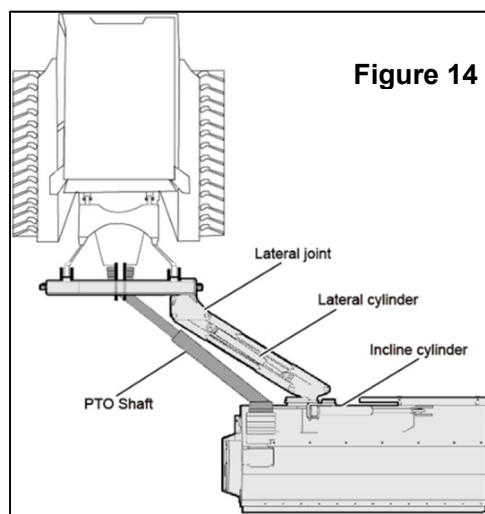

Figure 14

Note: If you have any problem during assembly & setup procedure, please contact us freely!

OPERATION

General Operating Instructions

Now that you have familiarized yourself with the Operator's Manual, completed the Operators Checklist, properly attached your mowers to your tractor, made the right offset or center adjustments, and preset your Crushing height, you're almost ready to begin using the mower. It's now time to do a running operational safety check. If at any time during this safety check you detect a malfunction in either the mowers or tractor shut the tractor off immediately, remove the key, and make necessary repairs or adjustments before continuing on.

Make sure the tractor's park brake is engaged, the tractor's PTO is disengaged, and the mowers are resting one ground. Start the tractor and then back the tractor throttle off till the engine is at low idle. With the tractor's rear hydraulic lift control lever, raise the mowers to transport position making sure that the PTO shaft is not in a bind and does not come in contact with the mowers frame. Lower the unit to Crushing position and, with the tractor still at low idle, engage the PTO. If everything is running smoothly at this point increase the engine rpm until the tractor's engine reaches full PTO operating speed which will be 540 rpm. Slowly raise the cutter to transport height to make sure the driveline does not bind or chatter. Then return the engine to low idle, disengage PTO, and position the adjustable stops on the tractor's hydraulic lift lever control console so the cutter can be consistently returned to the same Crushing and transport height.

You should now be ready to move to the Crushing site to begin working. You should have inspected and should only be Crushing in an area you are familiar with which is relatively free of debris and unseen objects. Never assume an area is clear. In the event you do strike an object, stop the tractor and mowers immediately to inspect the rotor and make any necessary repairs before resuming operation. It pays to inspect a new area and to develop a plan before cutting. Recommended working speed is less than 4 mph and you will need to maintain tractor PTO speed to produce a clean cut so make a tractor gear and range selection that will maintain this combination. Generally the quality of cut of will be better at lower ground speeds and crushing denser ground cover or heavier brush may create the need to slow down. Always cut downward on slopes and avoid crossing the face of steep slopes. Avoid sharp drops and cross diagonally through dips to prevent hanging up the tractor and mowers. Slow down in turns and avoid sharp turns if at all possible. Remember to look back often.

Now you're prepared and well briefed so let's begin Cutting. Reduce the tractor's engine rpm, make sure the mowers are on the ground and in Crushing position, engage the PTO, raise the engine rpm to the appropriate PTO speed, and begin working. Operators must plan a head and choose a Crushing route that allows safe turns. Try increasing or decreasing ground speed to determine the effect on quality of cut.

! CAUTION

Engage parking brake, shut off tractor, remove key, and disengage PTO before making any adjustments!

! CAUTION

Ensure mowers with special supports if it is necessary to lift mowers off the ground to make adjustments! If not supported, the mowers could fall causing serious injury to those present.

Checklist before Operation

 **CAUTION**

Hazard control and accident prevention are dependent upon the awareness, concern, prudence, and proper training involved in the operation, transport, storage, and maintenance of the shredder. Therefore, it is absolutely essential that no one operates the machine without first having read, fully understood, and become totally familiar with the Operator's Manual. Make sure all operators have completed the checklist below.

Before operating the machine, the following steps should be inspected carefully:

1. Before starting up the machine, check and lubricate all grease points, on the machine and drive shaft. Check the oil level in the gearbox. Add as required.
2. Use only an agricultural tractor with horsepower within limits of the implement.
3. Check that the machine is properly attached to the tractor. Be sure retainers are used on the mounting pins.
4. Be sure extra weights are mounted on the front of the tractor, if required.
5. Check that the tractor PTO shaft turns freely and that the machine driving shaft can telescope easily.
6. Check the blades. Be sure they are not damaged or broken and swing freely in their mount. Repair or replace as required.
7. Check and tighten the blade bolts.
8. Check for entangled material in all rotating parts. Remove this material.
9. Install and secure all guards, hook and covers before starting.

10. Before installing the PTO ensure the engine is stopped and the PTO shaft is in safe working order.
11. All other people shall leave the area before connecting the driving power from the tractor.
12. Before cleaning, repairing and lubricating the machine, stop the motor and take the key away with you.
13. When the PTO shaft is not connected with the tractor, support it through the frame to protect it from lying in the dirt.
14. Don't approach the machine when it is operating.

Levelling the Mower

Levelling adjustments are made at the tractor's 3-Point lower arms and top center link.

1. Park tractor and mower on a flat level surface.
2. Raise mower with the tractor's Hydraulic 3-Point lift slowly until the unit is about 1 to 2" above the ground.
3. Ensure that the lower arms are stabilized to prevent excessive side movement.
4. Place a spirit level on the top cover running from left to right and adjust one of the lower 3-Point arms up or down until the mowers are level from left to right.
5. Adjust tractor's top center link to place the upper hitch pin vertically above or slightly behind the lower hitch pins.
6. Slowly operate the tractor's 3-Point hydraulic control up and down to check for clearance between the tires, frame, drawbar.

Adjusting Lateral Position

If the mower has the lateral oil cylinder (named swing arm) or guide rail, the steps below user need to perform, otherwise does not.

See Figure 15

Note: Adjusting the lateral position must be carried out with the implement raised off the ground to avoid damaging the implement.

1. Stop forward travel with the tractor, place transmission in park or in neutral and set the park brake, reduce throttle speed to an idle, disengage power take-off, and raise the mower off the ground.
2. Extend the lateral cylinder to adjust the mower to the right or retract the lateral cylinder to adjust the mower to the left.

3. Once adjusted to the desired position, lower mower to the cutting height.
4. With engine speed at idle, engage PTO. Increase engine throttle to 540 power take-off speed.
5. Place transmission in appropriate gear range and begin traveling forward.

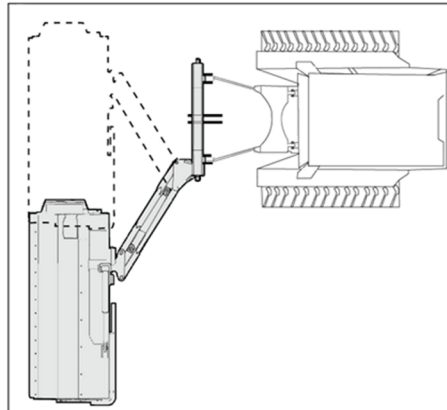

Figure 15

Adjusting Incline Angle

If the mower has the lateral oil cylinder (named rollover arm), the steps below user need to perform, otherwise does not.

See Figure 16

The incline angle of the flail head is adjustable to suit the job at hand. The incline angle may be rotated from -50° to $+90^{\circ}$ (angle range is reference) relative to the horizontal. Simply use the tractor control lever connected to the inclined cylinder to set the flail head to the preferred angle. The flail head should only be adjusted to follow the terrain.

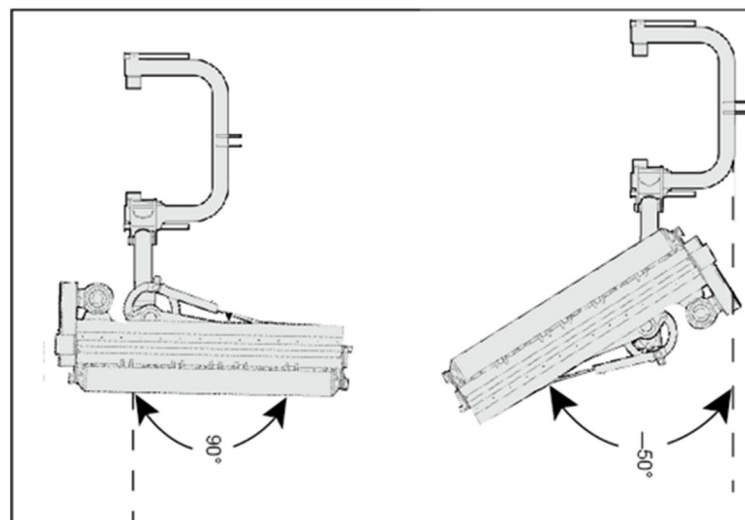

Figure 16

Adjusting Roller/Skid Height

CAUTION

The roller must be adjusted into the same position on both sides.

See Figure 17

To adjust roller / skid height:

1. Park tractor and implement on a flat, level surface.
2. Lower tractor lift arms to bring the roller in contact with the ground and make sure the flail head is parallel with the ground.
3. Shut tractor down according to procedures mentioned in tractor manual.
4. Raise and secure the implement with solid and firm support blocks.
5. Untighten and remove the height adjustment bolt as well as associated washers and nuts;
6. Adjust roller to the desired height by choosing one of the three locations.
7. Secure the bolts with removed washers and nuts.
8. Accordingly adjust the skid shoe by untightening the bolts as well as associated washers and nuts.
9. Inspect blades to make sure they do not touch the ground. Blades that come in contact with the ground will wear quickly. If necessary, readjust cutting height to keep blades from touching the ground.

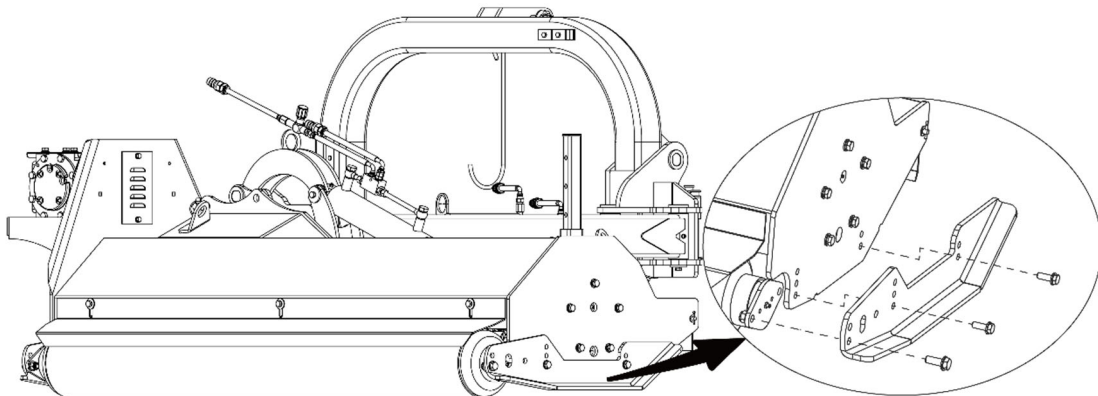

Figure 17

Starting the Machine

WARNING

- The flail shredder must only be in the working position while moving forward and must be raised when backing-up. Operating the flail shredder in the working position while backing-up can seriously damage the flail shredder.
- Never use the flail shredder with the tractor straddling a ditch.
- Only operate the flail shredder inclined when in the lateral extended configuration. When the shredder is in the center configuration, only operate it horizontally.
- Make sure that there are no persons or animals in the vicinity.

DANGER

To avoid tractor overturning hazard

- Never allow the tractor to take the weight of the flail shredder when working on inclined surfaces (ditches, slopes etc.), as the combined weight of the tractor and flail shredder may cause the tractor to overturn.
- Lightweight tractors with rear attached implements may need weights added to the front to maintain steering control.
- Consult your tractor Operator's Manual to determine proper weight requirements and maximum weight limitations.
- Survey any incline surface the tractor will be traveling on for holes and low depressions in the ground that the tractor wheel can drop into suddenly causing the tractor to overturn unexpectedly. Avoid such drop-offs.

Inspection before Starting

Before starting the machine, check and adjust the following items:

1. Drive belt tension.
2. Gearbox oil level.
3. Grease nipples on bearings and PTO shaft.
4. All bolts, nuts and screws.

Operation the Machine

See Figure 18

The incline cylinder must always be set to not float before raising the head off the ground. Mow while traveling forward only. Do not back-up while mowing. To back-up, follow the procedure below:

1. Stop traveling forward, disengage power take-off, set the incline cylinder to not float, and raise the mower off the ground.
2. Back-up with the mower above ground.
3. Lower the mower to the working position, set the incline cylinder to float if desired, engage power take-off, and continue mowing while traveling forward.

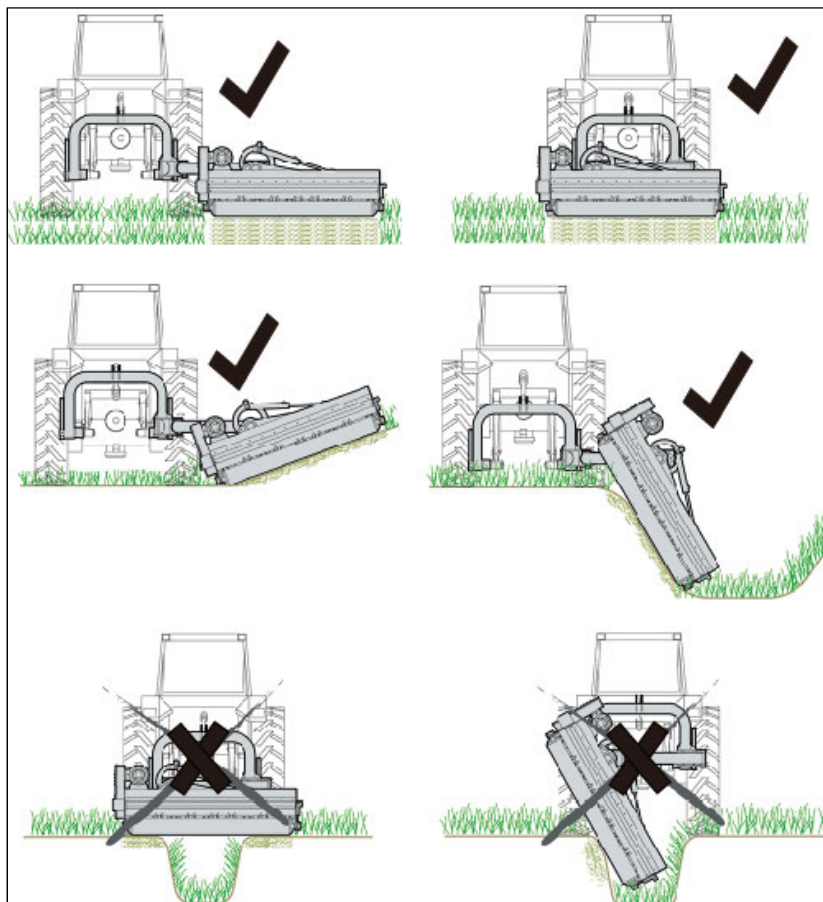

Figure 18

Note: If you have any problem during operation, please contact us freely!

SERVICE AND MAINTENANCE

General Service

The period recommended is based on normal operating conditions. Severe or unusual conditions may require more frequent service.

Each 4 hours of work:

Check and tighten nuts and bolts.

Grease with lithium based grease when it is indicated by the symbol GREASE.

After 50 hours of work:

Check and fill the gearbox to the required level, using oil type SAE EP 90W.

Gearbox Maintenance

The oil should be drained out and replaced after the first 50 hours of operation. Then the oil should be changed every 250 hours.

Drain oil from the gearbox thoroughly. Check and clean it. Fill with new gear oil up to the dedicated oil level.

The draining procedure is as follows: remove the draining bolt under the gear box, so that the oil drains off. After the oil is drained out, put the plug back and fill with gear oil up to the dedicated oil level.

PTO Shaft Maintenance





It is recommended to lubricate the PTO shaft with multi-purpose grease after every 8 to 10 hours of use during heavy use. The PTO shaft is designed to telescope to allow for dimensional changes as the machine goes through its operating range. A tubular guard encloses the driving components and is designed to turn relative to the driving components. The shaft should telescope easily and the guard turn freely on the shaft at all times. Annual disassembly, cleaning and lubrication is recommended to insure that all components function as intended. To maintain the shaft, follow this procedure:

1. Remove the shaft from the machine.
2. Pull shaft apart.
3. Use a screwdriver to pry the tabs out of the sleeves on each end.
4. Pull the shaft out of the plastic tubular guard.



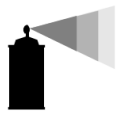

5. Use a solvent to clean the male and female portions of the telescoping ends.
6. Apply a light coat of grease to each end.
7. Clean the grooves on each end where the tabs are located. Clean each tab also.
8. Apply a light coat of grease to each groove.
9. Insert the shaft into its respective guard and align the slots with the groove.
10. Insert the tabs through the slots and seat in the groove.
11. Check that each guard turns freely on the shaft.
12. Assemble the shaft.
13. Check that the shaft telescopes easily.
14. Replace any components that are damaged or worn.
15. Install the shaft on the machine.



Lubrication Parts

Lubrication legend list:

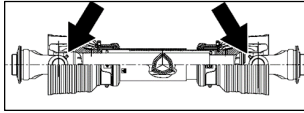
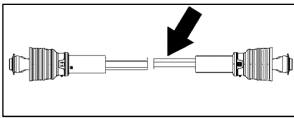
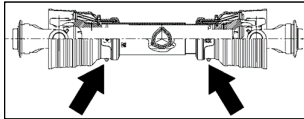
Name	Multi-purpose spray lube	Multi-purpose grease lube	Multi-purpose oil lube	Intervals in hours at which lubrication is required
Image				

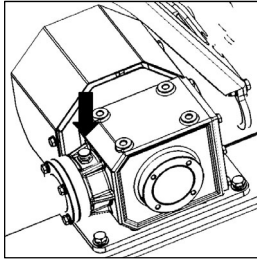
Lubrication parts list:

Interval	Type	Name	Parts Image	Remark
	 Multi-purpose Grease	Driveline Shaft U-Joints		Quantity - 4 to 8 Pumps
		Driveline Profiles		Quantity - Clean & coat inner profile tube of driveline with a light film of grease and then reassemble.
		Inner Tube Bearings		Quantity - As Required
	 SAE EP 90W Gear Lube	Gearbox		Add visual to the center of the gear oil Reinstall plugs and tighten. Do not overfill!

Interval	Type	Name	Parts Image	Remark
				Should your gearbox require service, take it to your Manufacturer dealer.
	 Multi-purpose Grease	Other parts	 If the GREASE labels () are posted on the machine, you need to lubricate it regularly. Recommend lubrication interval is 25hours.	

Tightening Torque

Please follow the table below to identify the torque value as required.

Torque Values Chart for Common Bolt Sizes													
Bolt Size (inches)	Bolt Head Identification						Bolt Size (Metric)	Bolt Head Identification					
	Grade 2		Grade 5		Grade 8			Class 5.8		Class 8.8		Class 10.9	
in-tpi ¹	N · m ²	ft-lb ³	N · m	ft-lb	N · m	ft-lb	mm x pitch ⁴	N · m	ft-lb	N · m	ft-lb	N · m	ft-lb
1/4" - 20	7.4	5.6	11	8	16	12	M 5 X 0.8	4	3	6	5	9	7
1/4" - 28	8.5	6	13	10	18	14	M 6 X 1	7	5	11	8	15	11
5/16" - 18	15	11	24	17	33	25	M 8 X 1.25	17	12	26	19	36	27
5/16" - 24	17	13	26	19	37	27	M 8 X 1	18	13	28	21	39	29
3/8" - 16	27	20	42	31	59	44	M10 X 1.5	33	24	52	39	72	53
3/8" - 24	31	22	47	35	67	49	M10 X 0.75	39	29	61	45	85	62
7/16" - 14	43	32	67	49	95	70	M12 X 1.75	58	42	91	67	125	93
7/16" - 20	49	36	75	55	105	78	M12 X 1.5	60	44	95	70	130	97
1/2" - 13	66	49	105	76	145	105	M12 X 1	90	66	105	77	145	105
1/2" - 20	75	55	115	85	165	120	M14 X 2	92	68	145	105	200	150
9/16" - 12	95	70	150	110	210	155	M14 X 1.5	99	73	155	115	215	160
9/16" - 18	105	79	165	120	235	170	M16 X 2	145	105	225	165	315	230
5/8" - 11	130	97	205	150	285	210	M16 X 1.5	155	115	240	180	335	245
5/8" - 18	150	110	230	170	325	240	M18 X 2.5	195	145	310	230	405	300
3/4" - 10	235	170	360	265	510	375	M18 X 1.5	220	165	350	260	485	355
3/4" - 16	260	190	405	295	570	420	M20 X 2.5	280	205	440	325	610	450
7/8" - 9	225	165	585	430	820	605	M20 X 1.5	310	230	650	480	900	665
7/8" - 14	250	185	640	475	905	670	M24 X 3	480	355	760	560	1050	780
1" - 8	340	250	875	645	1230	910	M24 X 2	525	390	830	610	1150	845
1" - 12	370	275	955	705	1350	995	M30 X 3.5	960	705	1510	1120	2100	1550
1-1/8" - 7	480	355	1080	795	1750	1290	M30 X 2	1060	785	1680	1240	2320	1710
1-1/8" - 12	540	395	1210	890	1960	1440	M36 X 3.5	1730	1270	2650	1950	3660	2700
1-1/4" - 7	680	500	1520	1120	2460	1820	M36 X 2	1880	1380	2960	2190	4100	3220
1-1/4" - 12	750	555	1680	1240	2730	2010							
1-3/8" - 6	890	655	1990	1470	3230	2380							
1-3/8" - 12	1010	745	2270	1670	3680	2710							
1-1/2" - 6	1180	870	2640	1950	4290	3160							
1-1/2" - 12	1330	980	2970	2190	4820	3560							

¹ in-tpi = nominal thread diameter in inches-threads per inch
² N · m = newton-meters
³ ft-lb = foot pounds
⁴ mm x pitch = nominal thread diameter in millimeters x thread pitch

Torque tolerance + 0%, -15% of torquing values. Unless otherwise specified use torque values listed above.
 All locknuts or lubricated fasteners: Use 75% of torque value. (i.e. 1/2"-13 GR5 = 76 ft-lb; 75% of 76 or .75 x 76 = 57 ft-lb)

- This chart is an approximate estimate of torque values.
- Always tighten hardware to these values unless a different torque value or tightening procedure is listed for a specific application.
- Fasteners must always be replaced with the same grades as specified in the manual.
- Always use the proper tool for tightening hardware; SAE for SAE hardware and Metric for Metric hardware.
- Make sure that fastener threads are clean and that you properly start thread engagement.

Replacing the Blade

Frequently check rotor blades to make sure they are in good working condition and properly secured to the rotor.

IMPORTANT:

- Make sure that the replacement of blade with other same weight. This will be a balance of rotor spinning.
- Recommend blade is the original factory accessories.

The blade have a Crushing edge on both the leading and trailing edges.

When the leading edge wears out, turn existing pair of blade around 180 ° and reinstall. Replaced blades should be the same length as original parts to maintain rotor balance.

Hammer blades replacement steps (See **Figure 19**):

1. Remove locknut (#0), spring washer (#1), hexagon head bolt (#3).
2. Remove existing blade (#2)
3. Install a new blade.
4. Install blade with bolt, washers, spring washer and locknut, refer to **Figure 19**.
5. Tighten locknut with correct torque.
6. Lubricate points.

Y type blades replacement steps (See **Figure 20**):

1. Remove locknut (#0), spring washer (#1), hexagon head bolt (#4), blade spacer (#2).
2. Remove the existing blade (#3).
3. Install a new blade.
4. Install blade with bolt, washers, spring washer and locknut, refer to **Figure 20**.
5. Tighten locknut with correct torque.
6. Lubricate points.

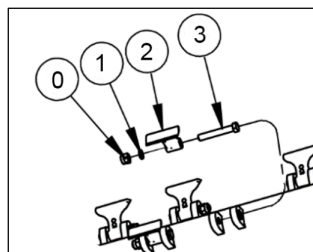

Figure 19

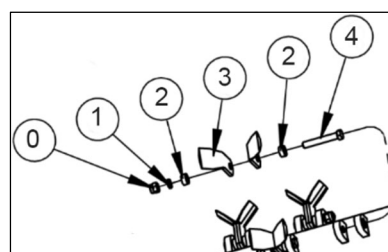

Figure 20

STORAGE AND TRANSPORT

Storage

Listed general storage is the common that may or may not be application to sweeper the described in this manual.

To insure maximum performance and minimum deterioration, the following procedures should be performed when the mower will be idle for more than 30days:

1. Wash the mower and let dry (Waxing will help prevent paint oxidation).
2. Change oil.
3. Charge battery (if implement has) fully and disconnect the battery leads.
4. Fill fuel tank within 2 inches of filled neck (keeps out condensation) and add fuel conditioner.
5. Squirt a small amount of oil into cylinders and crank the engine over a few times.
6. Grease all pivot pins. Liberally apply cup grease to all bare metal surfaces such as buckets and exposed cylinder rods. Grease all pivot pins. Retract all cylinder rods. Use penetrating oil (Recommended WD40) on all electrical parts and areas inaccessible to regular grease.
7. Set the mower on stands so the tires are off the ground. (Keeps tires from developing flat spots.)
8. Deflate tires to 1/2 pressure to relax cords.
9. Use a protective on hoses, seat and tires to keep them from weathering.
10. If the sweeper is to be stored outside, cover with a tarp or plastic cover to minimize weathering.

Transport

WARNING

- Always disengage power take-off before raising shredder to transport position.
- When traveling on roadways, travel in such a way that other vehicles may pass you safely. Always use LED lights, clean reflectors, and a slow moving vehicle sign that is visible from the back to warn operators in other vehicles of your presence.
- Always comply with all federal, state, and local laws.

Before transport the implement, you should following the steps below:

1. When raising mower to transport position, be sure driveline does not contact tractor or mower. If needed, adjust and set tractor 3-point lift height to limit mower movement and to protect driveline.
2. Be sure to reduce tractor ground speed when turning, leaving enough clearance so that the mower does not contact obstacles such as buildings, trees, fences, etc.
3. Select a safe ground travel speed when transporting from one area to another. When traveling on roadways, transport in such a way that faster moving vehicles may pass safely.
4. When traveling over rough or hilly terrain, shift tractor to a lower gear.

TROUBLESHOOTING

Listed general troubleshooting is the common malfunction that may or may not be application to the described in this manual. If you have any problem not covered in the list, please contact us for technical supporting.

General troubleshooting list:

Malfunction	Possible Cause	Solution
Belt slippage	Blades touch the ground	Adjust the skids or roller correctly
	Belts worn	Replace a new belts
	Belt is not tensioned correctly	Correct belt tension, see Adjusting the Belt
	Belt tensioner is damaged	Replace a new one
	Clogging	Clean the machine to remove accumulated debris.
Belt failure	Incorrect belt alignment	Align the belts.
	Belt tensioner spring has lost its memory or is broken	Replace belt tensioner spring and belts.
Significant machine vibration	Worn blades	Replace the blades
	Missing blades	
	Broken blades	
	Worn rotor support bearings	Replace the bearings
	Rotor fouled with debris	Clean rotor
	Loose parts	Tighten bolts and fasteners
	Incorrect power take-off speed	Select correct tractor power take-off speed
Excessively rapid blade wear	Blades touching the ground	Check and, if necessary, adjust cut height.
Blades tear rather than cut, shredded material not distributed evenly	Ground speed too high	Reduce the speed
	Cut height too low	Adjust cut height
	Excessive build-up of material under the flail head	Clean the flail head

Malfunction	Possible Cause	Solution
	Clogging	Clean the machine to remove accumulated debris
Roller does not turn easily	Insufficient greasing	Grease as indicated
	Roller casing bearings worn	Replace the bearings
	Roller or mounts damaged or bent	Replace damaged parts
Excessive driveline noise	Insufficient greasing	Apply grease as indicated in the Maintenance section
	Worn trunnion bearing	Replace bearings
	Exceeds 25 degrees	Do not exceed 25 degrees
Driveline wear	Insufficient greasing	Apply grease as indicated in the Maintenance section
	Operating angle incorrect	Reduce the operating angle
	Overloading	Avoid overloading and do not start the machine when loaded
Breakage or deformation of the driveline	Overloading	Avoid overloading and do not start the machine when loaded
	Operating angle incorrect	Reduce the operating angle
Unit overheating	Not enough oil in the unit	Check seals and gaskets and replace any that are damaged
		Top off the oil
	Incorrect oil type	Replace with the prescribed type of oil
	Excessive oil	Restore correct oil level
	Overloading	Observe the prescribed speed and power conditions
Lateral adjustment and/or inclination angle adjustment functions not working correctly	Hoses connected incorrectly to tractor remotes	Connect correctly
	Remotes or hydraulic pump on tractor faulty	Check and repair if necessary
	Oil leakage	Check connections and tighten correctly if necessary
		Check hydraulic hoses and replace if necessary

EXPLODED VIEW AND PARTS LIST

MACHINE ASSEMBLY

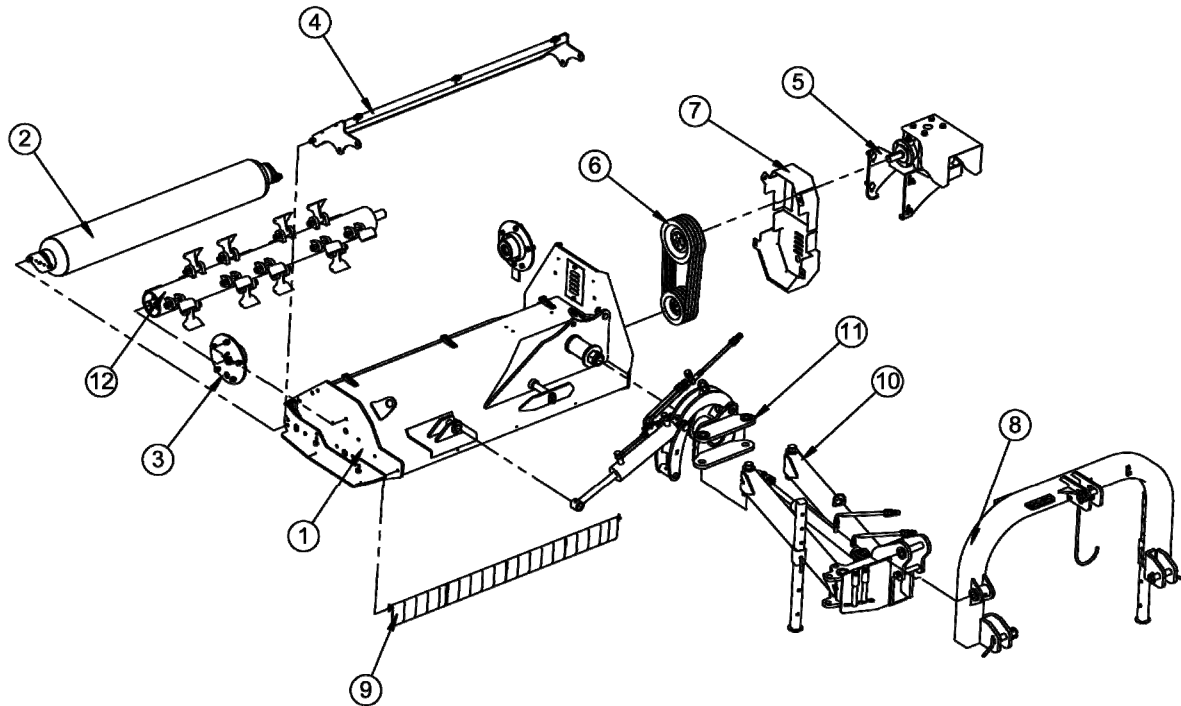

Machine optional part list:

CODE	Specification	Description	Model
1030200100	R02001A00000-000	Flail mower	ME-VFLMO54
1030200101	R02002A00000-000	Flail mower	ME-VFLMO64
1030200102	R02003A00000-000	Flail mower	ME-VFLMO72
1030200103	R02004A00000-000	Flail mower	ME-VFLMO78
1030200104	R02005A00000-000	Flail mower	ME-VFLMO86
1030200105	R02006A00000-000	Flail mower	ME-VFLMO54T(KF)
1030200106	R02007A00000-000	Flail mower	ME-VFLMO64T(KF)
1030200107	R02008A00000-000	Flail mower	ME-VFLMO72T(KF)
1030200108	R02009A00000-000	Flail mower	ME-VFLMO78T(KF)
1030200109	R02010A00000-000	Flail mower	ME-VFLMO86T(KF)

Machine assembly parts name list:

POS.	COD.	Specification	Description	54/ QTY	64/ QTY	72/ QTY	78/ QTY	86/ QTY
1	2060105908	R02001A01000-000	Hood assembly	1	-	-	-	-
1	2060105909	R02002A01000-000	Hood assembly	-	1	-	-	-
1	2060105910	R02003A01000-000	Hood assembly	-	-	1	-	-
1	2060105911	R02004A01000-000	Hood assembly	-	-	-	1	-
1	2060105912	R02005A01000-000	Hood assembly	-	-	-	-	1
2	2060105922	R02001A03000-000	Drum assembly	1	-	-	-	-
2	2060105923	R02002A03000-000	Drum assembly	-	1	-	-	-
2	2060105924	R02003A03000-000	Drum assembly	-	-	1	-	-
2	2060105925	R02004A03000-000	Drum assembly	-	-	-	1	-
2	2060105926	R02005A03000-000	Drum assembly	-	-	-	-	1
3	2060108029	R02001A04000-000	Bearing seat assembly	1	1	1	1	1
4	2060105929	R02006A05000-000	Rear cover assembly	-	-	-	-	-
4	2060105930	R02007A05000-000	Rear cover assembly	-	-	-	-	-
4	2060105931	R02008A05000-000	Rear cover assembly	-	-	-	-	-
4	2060105932	R02009A05000-000	Rear cover assembly	-	-	-	-	-
4	2060105933	R02010A05000-000	Rear cover assembly	-	-	-	-	-
5	2060107037	R02001E06000-000	Gearbox drive shaft	1	1	1	1	1
6	2060105936	R02001A07000-000	Side drive assembly	1	1	1	1	1
7	2060105939	R02001A08000-000	Side shield assembly	1	1	1	1	1
8	2060105940	R02001A09000-000	Suspension assembly	1	1	1	1	1
9	2060105942	R02001A10000-000	Protection components	1	-	-	-	-
9	2060105943	R02002A10000-000	Protection components	-	1	-	-	-
9	2060105944	R02003A10000-000	Protection components	-	-	1	-	-
9	2060105945	R02004A10000-000	Protection components	-	-	-	1	-
9	2060105946	R02005A10000-000	Protection components	-	-	-	-	1
10	2060105950	R02001A11000-000	Swing assembly	1	1	1	1	1

POS.	COD.	Specification	Description	54/ QTY	64/ QTY	72/ QTY	78/ QTY	86/ QTY
11	2060105953	R02001A12000-000	Rollover assembly	1	1	1	1	1
12	2090000178	R02001A02000-000	Ordinary Axle +hammer blade	1	-	-	-	-
12	2090000179	R02002A02000-000	Ordinary Axle +hammer blade	-	1	-	-	-
12	2090000180	R02003A02000-000	Ordinary Axle +hammer blade	-	-	1	-	-
12	2090000181	R02004A02000-000	Ordinary Axle +hammer blade	-	-	-	1	-
12	2090000182	R02005A02000-000	Ordinary Axle +hammer blade	-	-	-	-	1

Machine assembly parts name list:

POS.	COD.	Specification	Description	54T/ QTY	64T/ QTY	72T/ QTY	78T/ QTY	86T/ QTY
1	2060105913	R02006A01000-000	Hood assembly	1	-	-	-	-
1	2060105914	R02007A01000-000	Hood assembly	-	1	-	-	-
1	2060105915	R02008A01000-000	Hood assembly	-	-	1	-	-
1	2060105916	R02009A01000-000	Hood assembly	-	-	-	1	-
1	2060105917	R02010A01000-000	Hood assembly	-	-	-	-	1
2	2060105922	R02001A03000-000	Drum assembly	1	-	-	-	-
2	2060105923	R02002A03000-000	Drum assembly	-	1	-	-	-
2	2060105924	R02003A03000-000	Drum assembly	-	-	1	-	-
2	2060105925	R02004A03000-000	Drum assembly	-	-	-	1	-
2	2060105926	R02005A03000-000	Drum assembly	-	-	-	-	1
3	2060108029	R02001A04000-000	Bearing seat assembly	1	1	1	1	1
4	2060105929	R02006A05000-000	Rear cover assembly	1	-	-	-	-
4	2060105930	R02007A05000-000	Rear cover assembly	-	1	-	-	-
4	2060105931	R02008A05000-000	Rear cover assembly	-	-	1	-	-
4	2060105932	R02009A05000-000	Rear cover assembly	-	-	-	1	-
4	2060105933	R02010A05000-000	Rear cover assembly	-	-	-	-	1
5	2060107037	R02001E06000-000	Gearbox drive shaft	1	1	1	1	1
6	2060105936	R02001A07000-000	Side drive assembly	1	1	1	1	1

POS.	COD.	Specification	Description	54T/ QTY	64T/ QTY	72T/ QTY	78T/ QTY	86T/ QTY
7	2060105939	R02001A08000-000	Side shield assembly	1	1	1	1	1
8	2060105940	R02001A09000-000	Suspension assembly	1	1	1	1	1
9	2060105942	R02001A10000-000	Protection components	1	-	-	-	-
9	2060105943	R02002A10000-000	Protection components	-	1	-	-	-
9	2060105944	R02003A10000-000	Protection components	-	-	1	-	-
9	2060105945	R02004A10000-000	Protection components	-	-	-	1	-
9	2060105946	R02005A10000-000	Protection components	-	-	-	-	1
10	2060105950	R02001A11000-000	Swing assembly	1	1	1	1	1
11	2060105953	R02001A12000-000	Rollover assembly	1	1	1	1	1
12	2090000178	R02001A02000-000	Ordinary Axle +hammer blade	1	-	-	-	-
12	2090000179	R02002A02000-000	Ordinary Axle +hammer blade	-	1	-	-	-
12	2090000180	R02003A02000-000	Ordinary Axle +hammer blade	-	-	1	-	-
12	2090000181	R02004A02000-000	Ordinary Axle +hammer blade	-	-	-	1	-
12	2090000182	R02005A02000-000	Ordinary Axle +hammer blade	-	-	-	-	1

HOOD ASSEMBLY

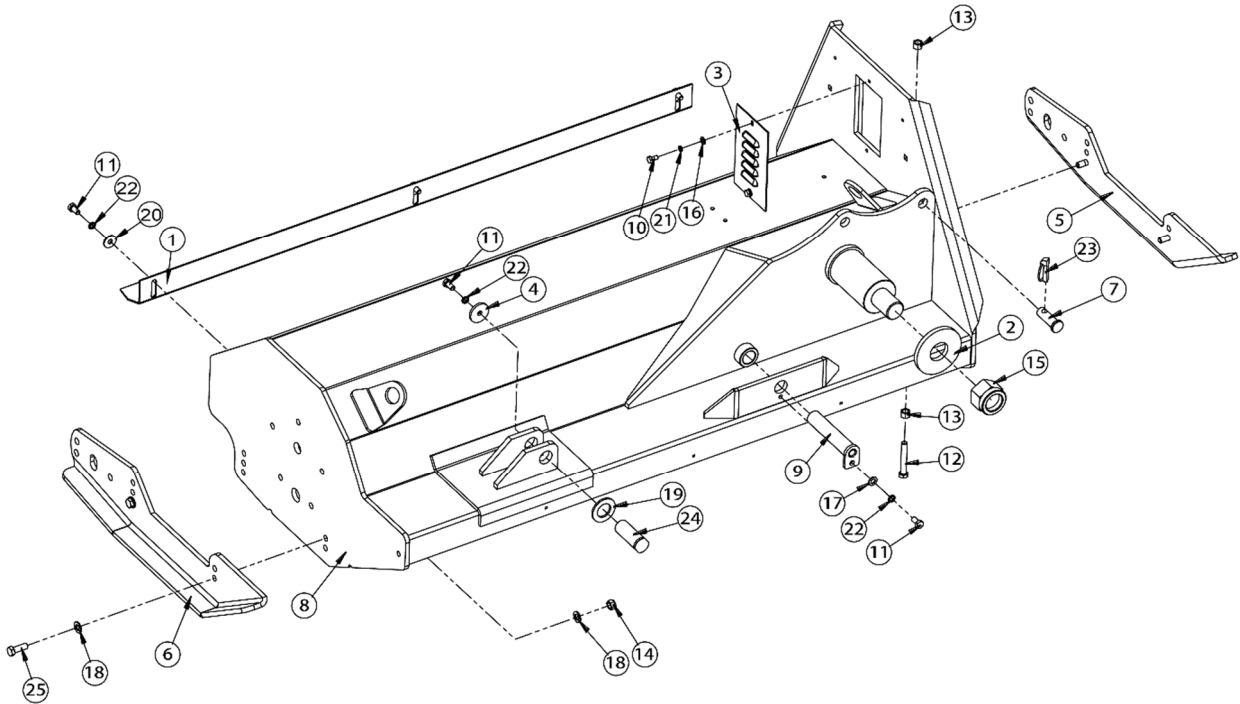

Hood assembly (ME-VFLMO54/64/72/78/86) options list:

COD.	Specification	Description	Model
2060105908	R02001A01000-000	Hood assembly	ME-VFLMO54
2060105909	R02002A01000-000	Hood assembly	ME-VFLMO64
2060105910	R02003A01000-000	Hood assembly	ME-VFLMO72
2060105911	R02004A01000-000	Hood assembly	ME-VFLMO78
2060105912	R02005A01000-000	Hood assembly	ME-VFLMO86

Hood assembly (ME-VFLMO54/64/72/78/86) parts name list:

POS.	COD.	Specification	Description	54/ QTY	64/ QTY	72/ QTY	78/ QTY	86/ QTY
1	2000000118	R02001A01000-007	Clean shoe	1	-	-	-	-
1	2000000119	R02002A01000-007	Clean shoe	-	1	-	-	-
1	2000000120	R02003A01000-007	Clean shoe	-	-	1	-	-
1	2000000121	R02004A01000-007	Clean shoe	-	-	-	1	-
1	2000000122	R02005A01000-007	Clean shoe	-	-	-	-	1
2	2000000123	R02001A01000-005	Washer	1	1	1	1	1
3	2000000124	R02001A01000-002	Plate	1	1	1	1	1

POS.	COD.	Specification	Description	54/ QTY	64/ QTY	72/ QTY	78/ QTY	86/ QTY
4	2000000125	G05001A25000-007	Washer	1	1	1	1	1
5	2000000127	R02001A01000-004	Left skateboard	1	1	1	1	1
6	2000000152	R02001A01000-001	Right skateboard	1	1	1	1	1
7	2010000093	R02001A01000-006	Pin	1	1	1	1	1
8	2020000284	R02001A01100-000	Hood welding fittings	1	-	-	-	-
8	2020000285	R02002A01100-000	Hood welding fittings	-	1	-	-	-
8	2020000286	R02003A01100-000	Hood welding fittings	-	-	1	-	-
8	2020000287	R02004A01100-000	Hood welding fittings	-	-	-	1	-
8	2020000288	R02005A01100-000	Hood welding fittings	-	-	-	-	1
9	2020000298	R02001A01200-000	Pin welding	1	1	1	1	1
10	3040100021	GB/T5783-M8×16-8.8-EP•Zn	Full-thread hex. bolts	2	2	2	2	2
11	3040100041	GB/T5783-M10×20-8.8-EP•Zn	Full-thread hex. bolts	5	5	5	5	5
12	3040100079	GB/T5783-M12×80-8.8-EP•Zn	Full-thread hex. bolts	2	2	2	2	2
13	3050100007	GB/T41-M12-5-EP•Zn	Hexagon nuts	4	4	4	4	4
14	3050500007	GB/T889.1-M12-8-EP•Zn	Locknut	4	4	4	4	4
15	3050600015	GB/T889.2-M42×3-8-EP•Zn	Locknut (fine pitch)	1	1	1	1	1
16	3080100004	GB/T95-8-EP•Zn	Plain washer	2	2	2	2	2
17	3080100006	GB/T95-10-EP•Zn	Plain washer	1	1	1	1	1
18	3080100007	GB/T95-12-EP•Zn	Plain washer	8	8	8	8	8
19	3080100015	GB/T95-30-EP•Zn	Plain washer	1	1	1	1	1
20	3080200009	GB/T96.2-10-EP•Zn	Large plain washer	3	3	3	3	3
21	3080500007	GB/T93-8-EP•Zn	Spring washer	2	2	2	2	2
22	3080500008	GB/T93-10-EP•Zn	Spring washer	5	5	5	5	5
23	3120400007	GB/T4329-12-EP•Zn	Pin	1	1	1	1	1
24	3120500004	R02001A01000-003	Pin	1	1	1	1	1
25	3040100069	GB/T5783-M12×35-8.8-EP•Zn	Full-thread hex. bolts	4	4	4	4	4

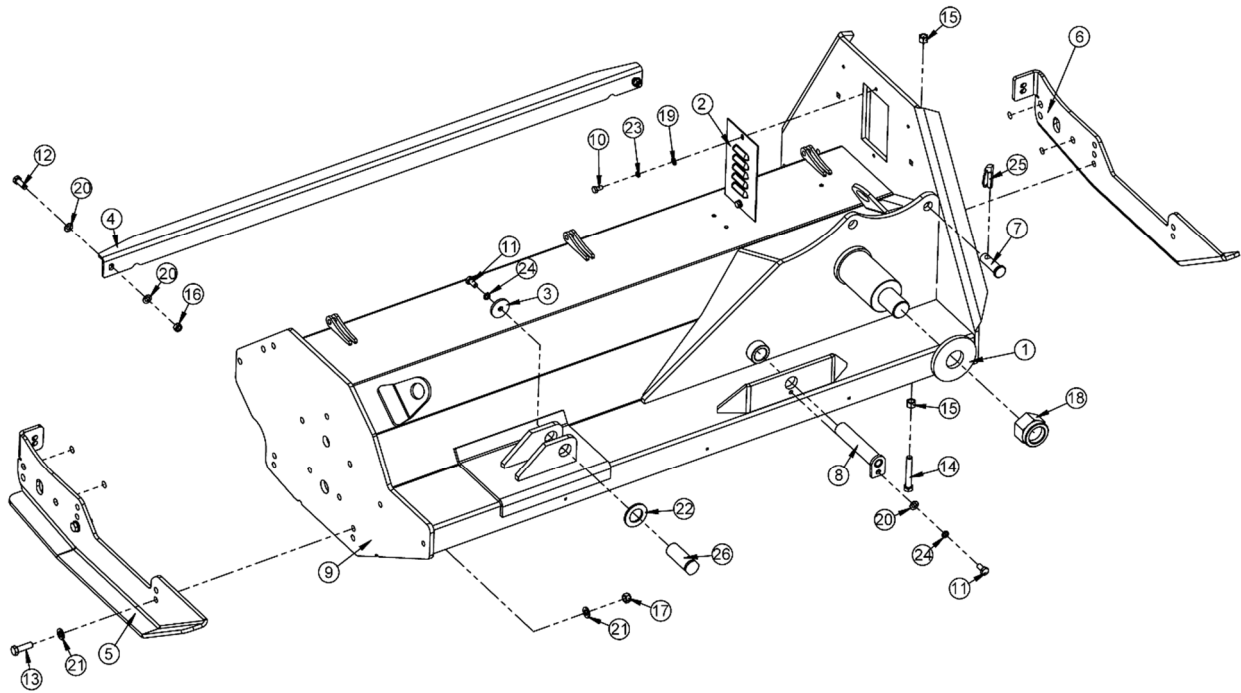

Hood assembly (ME-VFLMO54T/64T/72T/78T/86T) options list:

COD.	Specification	Description	Model
2060105913	R02006A01000-000	Hood assembly	ME-VFLMO54T
2060105914	R02007A01000-000	Hood assembly	ME-VFLMO64T
2060105915	R02008A01000-000	Hood assembly	ME-VFLMO72T
2060105916	R02009A01000-000	Hood assembly	ME-VFLMO78T
2060105917	R02010A01000-000	Hood assembly	ME-VFLMO86T

Hood assembly (ME-VFLMO54T/64T/72T/78T/86T) parts name list:

POS.	COD.	Specification	Description	54T/ QTY	64T/ QTY	72T/ QTY	78T/ QTY	86T/ QTY
1	2000000123	R02001A01000-005	Washer	1	1	1	1	1
2	2000000124	R02001A01000-002	Plate	1	1	1	1	1
3	2000000125	G05001A25000-007	Washer	1	1	1	1	1
4	2000000181	R02006A01000-007	Clean shoe	1	-	-	-	-
4	2000000182	R02007A01000-007	Clean shoe	-	1	-	-	-
4	2000000183	R02008A01000-007	Clean shoe	-	-	1	-	-
4	2000000184	R02009A01000-007	Clean shoe	-	-	-	1	-
4	2000000185	R02010A01000-007	Clean shoe	-	-	-	-	1
5	2000000186	R02006A01000-001	Right skateboard	1	1	1	1	1
6	2000000187	R02006A01000-004	Left skateboard	1	1	1	1	1

POS.	COD.	Specification	Description	54T/ QTY	64T/ QTY	72T/ QTY	78T/ QTY	86T/ QTY
7	201000093	R02001A01000-006	Pin	1	1	1	1	1
8	2020000298	R02001A01200-000	Pin welding	1	1	1	1	1
9	2020000403	R02006A01100-000	Hood welding fittings	1	-	-	-	-
9	2020000404	R02007A01100-000	Hood welding fittings	-	1	-	-	-
9	2020000405	R02008A01100-000	Hood welding fittings	-	-	1	-	-
9	2020000406	R02009A01100-000	Hood welding fittings	-	-	-	1	-
9	2020000407	R02010A01100-000	Hood welding fittings	-	-	-	-	1
10	3040100021	GB/T5783-M8×16-8.8	Full-thread hex. bolts	2	2	2	2	2
11	3040100041	GB/T5783-M10×20-8.8	Full-thread hex. bolts	2	2	2	2	2
12	3040100045	GB/T5783-M10×30-8.8	Full-thread hex. bolts	2	2	2	2	2
13	3040100071	GB/T5783-M12×40-8.8	Full-thread hex. bolts	4	4	4	4	4
14	3040100079	GB/T5783-M12×80-8.8	Full-thread hex. bolts	2	2	2	2	2
15	3050100007	GB/T41-M12-5-EP•Zn	Hex. nuts	4	4	4	4	4
16	3050500004	GB/T889.1-M10-8-EP•Zn	Locknut	2	2	2	2	2
17	3050500007	GB/T889.1-M12-8-EP•Zn	Locknut	4	4	4	4	4
18	3050600015	GB/T889.2-M42×3-8-EP•Zn	Locknut (fine pitch)	1	1	1	1	1
19	3080100004	GB/T95-8-EP•Zn	Plain washer	2	2	2	2	2
20	3080100006	GB/T95-10-EP•Zn	Plain washer	5	5	5	5	5
21	3080100007	GB/T95-12-EP•Zn	Plain washer	8	8	8	8	8
22	3080100015	GB/T95-30-EP•Zn	Plain washer	1	1	1	1	1
23	3080500007	GB/T93-8-EP•Zn	Spring washer	2	2	2	2	2
24	3080500008	GB/T93-10-EP•Zn	Spring washer	2	2	2	2	2
25	3120400007	GB/T4329-12-EP•Zn	Pin	1	1	1	1	1
26	3120500004	R02001A01000-003	Pin	1	1	1	1	1

DRUM ASSEMBLY

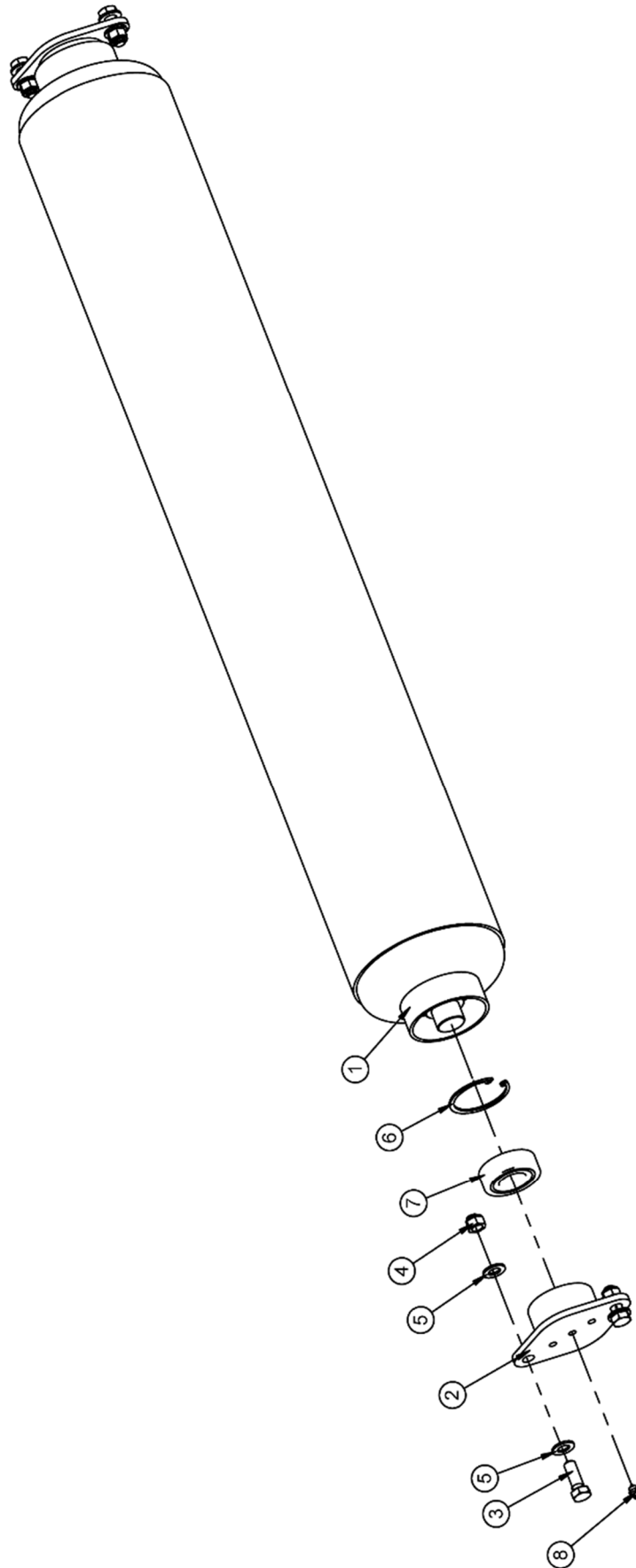

Drum assembly options list:

COD.	Specification	Description	Model	Note
2060105922	R02001A03000-000	Drum assembly	ME-VFLMO54 ME-VFLMO54T	Option
2060106088	R02001B03000-000	Drum assembly(SKf)		
2060105923	R02002A03000-000	Drum assembly	ME-VFLMO64 ME-VFLMO64T	Option
2060106089	R02002B03000-000	Drum assembly(SKf)		
2060105924	R02003A03000-000	Drum assembly	ME-VFLMO72 ME-VFLMO72T	Option
2060106090	R02003B03000-000	Drum assembly(SKf)		
2060105925	R02004A03000-000	Drum assembly	ME-VFLMO78 ME-VFLMO78T	Option
2060106091	R02004B03000-000	Drum assembly(SKf)		
2060105926	R02005A03000-000	Drum assembly	ME-VFLMO86 ME-VFLMO86T	Option
2060106092	R02005B03000-000	Drum assembly(SKf)		

Drum assembly parts name list:

POS.	COD.	Specification	Description	54(T)/ QTY	64(T)/ QTY	72(T)/ QTY	78(T)/ QTY	86(T)/ QTY
1	2020000289	R02001A03100-000	Drum welding fittings	1	-	-	-	-
1	2020000290	R02002A03100-000	Drum welding fittings	-	1	-	-	-
1	2020000291	R02003A03000-000	Drum welding fittings	-	-	1	-	-
1	2020000292	R02004A03100-000	Drum welding fittings	-	-	-	1	-
1	2020000293	R02005A03100-000	Drum welding fittings	-	-	-	-	1
2	2020000294	R02001A03200-000	Bearing seat	2	2	2	2	2
3	3040100092	GB/T5783-M14×40-8.8	Full-thread hex. bolts	4	4	4	4	4
4	3050500008	GB/T889.1-M14-8-EP•Zn	Locknut	4	4	4	4	4
5	3080100008	GB/T95-14-EP•Zn	Plain washer	8	8	8	8	8
6	3080600043	GB/T893-72-A	Retaining rings	2	2	2	2	2
7	3100200010	GB/T281-2207-RS	Ball bearing	2	2	2	2	2
	3100200605	2207-RS(SKf)	Ball bearing	2	2	2	2	2
8	3170400004	JB/T7940.1-M10×1 304	Grease nipple	2	2	2	2	2

BEARING SEAT ASSEMBLY

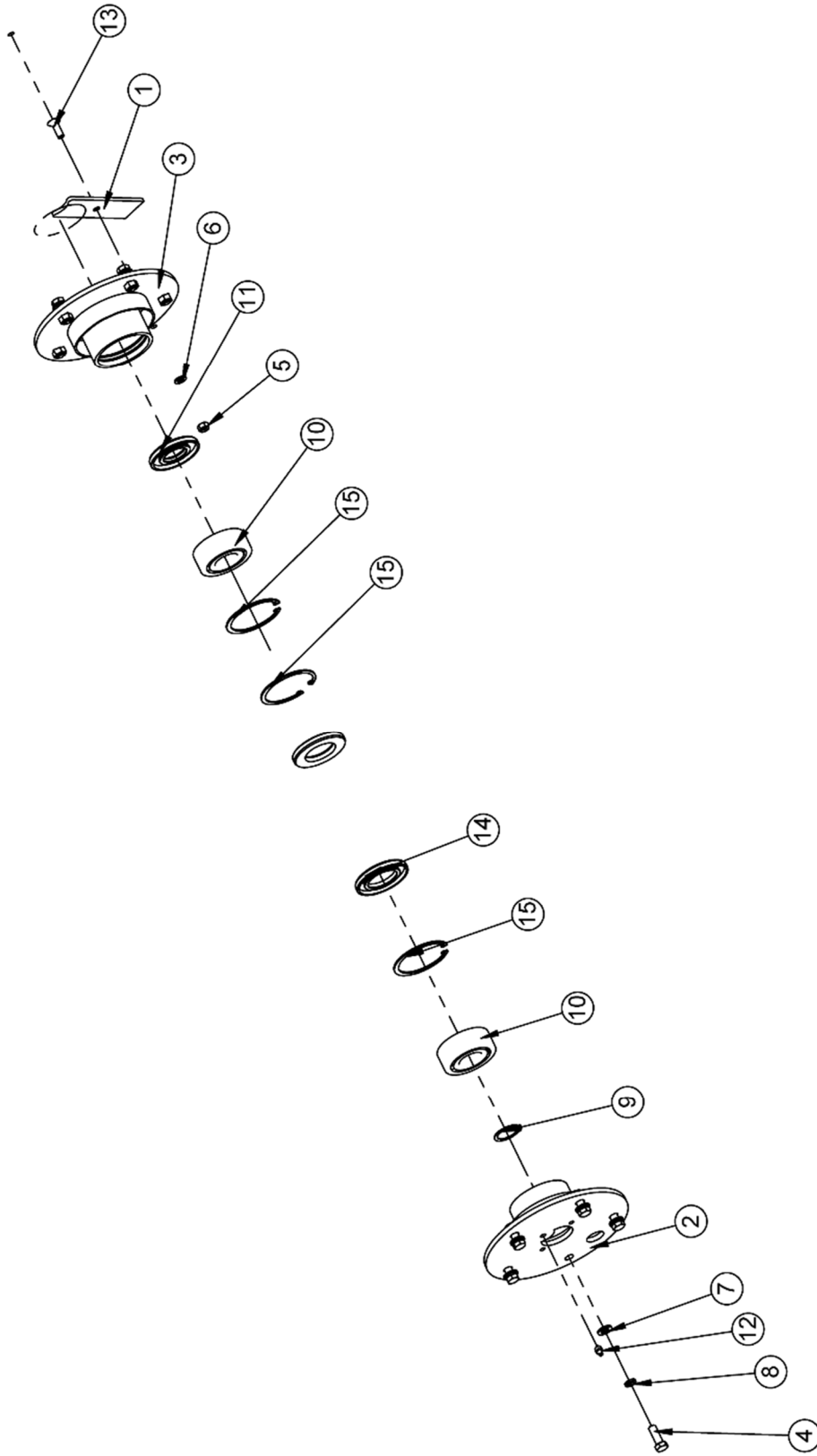

Bearing seat assembly parts list:

POS.	COD.	Specification	Description	54(T)/ QTY	64(T)/ QTY	72(T)/ QTY	78(T)/ QTY	86(T)/ QTY
1	200000128	R02001A04000-001	Plate	1	1	1	1	1
2	2020000304	R02001A04100-000	Left bearing seat	1	1	1	1	1
3	2020000305	R02001A04200-000	Right bearing seat	1	1	1	1	1
4	3040100069	GB/T5783-M12×35-8.8	Full-thread hex. bolts	10	10	10	10	10
5	3050500004	GB/T889.1-M10-8-EP•Zn	Locknut	1	1	1	1	1
6	3080100006	GB/T95-10-EP•Zn	Plain washer	1	1	1	1	1
7	3080100007	GB/T95-12-EP•Zn	Plain washer	10	10	10	10	10
8	3080500009	GB/T93-12-EP•Zn	Spring washer	10	10	10	10	10
9	3080700026	GB/T894-40-A	Retaining rings	1	1	1	1	1
10	3100200011	GB/T281-2308	Ball bearing	2	2	2	2	2
	3100200005	SKF-2308	Ball bearing	2	2	2	2	2
11	3170100022	GB/T13871.1-FB40×85×10	Shaft seal	1	1	1	1	1
12	3170400004	JB/T7940.1-M10×1 304	Grease nipple	1	1	1	1	1
13	3060200034	GB/T70.3-M10×30-8.8	HSCS-Countersunk	1	1	1	1	1
14	3170100041	GB/T13871.1-FB 50×90×10	Shaft seal	2	2	2	2	2
15	3080600050	GB/T893-90-A	Retaining rings	3	3	3	3	3

REAR COVER ASSEMBLY

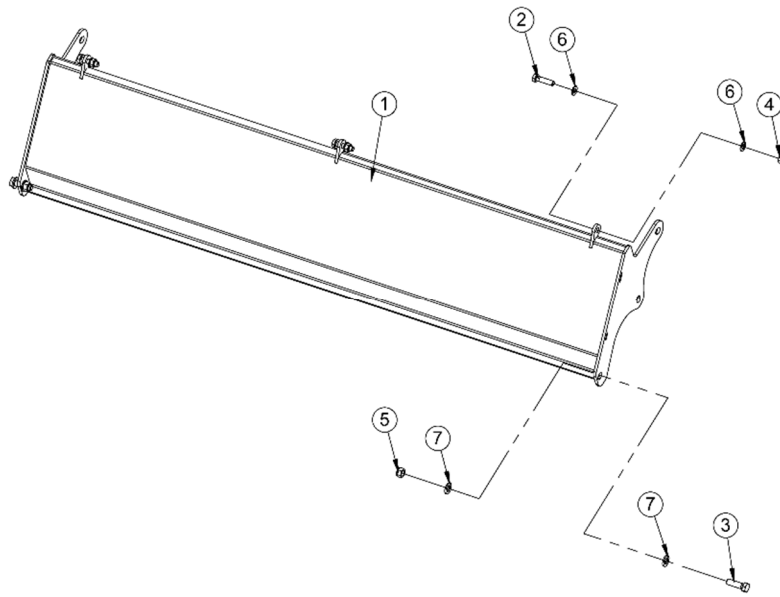

Rear cover options list:

COD.	Specification	Description	Model
2060105929	R02006A05000-000	Rear cover assembly	ME-VFLMO54T
2060105930	R02007A05000-000	Rear cover assembly	ME-VFLMO64T
2060105931	R02008A05000-000	Rear cover assembly	ME-VFLMO72T
2060105932	R02009A05000-000	Rear cover assembly	ME-VFLMO78T
2060105933	R02010A05000-000	Rear cover assembly	ME-VFLMO86T

Rear cover parts list:

POS.	COD.	Specification	Description	54T/ QTY	64T/ QTY	72T/ QTY	78T/ QTY	86T/ QTY
1	2020000408	R02006A05100-000	Cover plate	1	-	-	-	-
1	2020000409	R02007A05100-000	Cover plate	-	1	-	-	-
1	2020000410	R02008A05100-000	Cover plate	-	-	1	-	-
1	2020000411	R02009A05100-000	Cover plate	-	-	-	1	-
1	2020000412	R02010A05100-000	Cover plate	-	-	-	-	1
2	3040100047	GB/T5783-M10×40-8.8	Hex. bolts	3	4	4	4	4
3	3040100071	GB/T5783-M12×40-8.8	Hex. bolts	2	2	2	2	2
4	3050500004	GB/T889.1-M10-8-EP•Zn	Locknut	3	4	4	4	4

POS.	COD.	Specification	Description	54T/ QTY	64T/ QTY	72T/ QTY	78T/ QTY	86T/ QTY
5	3050500007	GB/T889.1-M12-8-EP•Zn	Locknut	2	2	2	2	2
6	3080100006	GB/T95-10-EP•Zn	Plain washer	6	8	8	8	8
7	3080100007	GB/T95-12-EP•Zn	Plain washer	4	4	4	4	4

GEARBOX DRIVE SHAFT

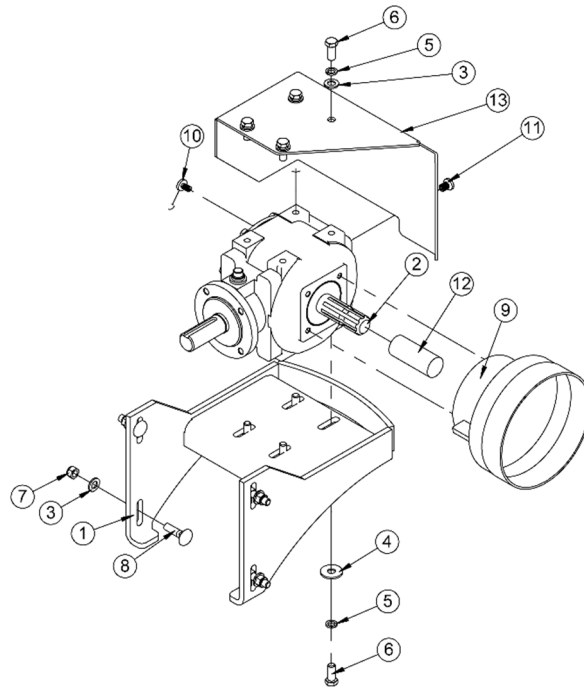

Gearbox drive shaft (plastic) parts list:

POS.	COD.	Specification	Description	Plastic
1	2020000295	R02001A06100-000	Gearbox mounting plate	1
2	3160100016	XH50.300Z.03W-Black	Gear box	1
3	3080100007	GB/T95-12-EP•Zn	Plain washer	8
4	3080200010	GB/T96.2-12-EP•Zn	Large plain washer	4
5	3080500009	GB/T93-12-EP•Zn	Spring washer	8
6	3040100067	GB/T5783-M12×30-8.8-EP•Zn	Full-thread hex. bolts	8
7	3050500007	GB/T889.1-M12-8-EP•Zn	Locknut	4
8	3041700008	GB/T794-M12×45-8.8-EP•Zn	Head square neck bolt	4
9	2060205018	R02001B06200-000	PTO safety cover assembly	1

POS.	COD.	Specification	Description	Plastic
10	3210200605	M10×16	Pipe Plug	4
11	3210200606	M12×16	Pipe Plug	4
12	3210500603	Φ35×90	Rubber	1
13	2000006274	R02001B06000-001	Gearbox cover	1

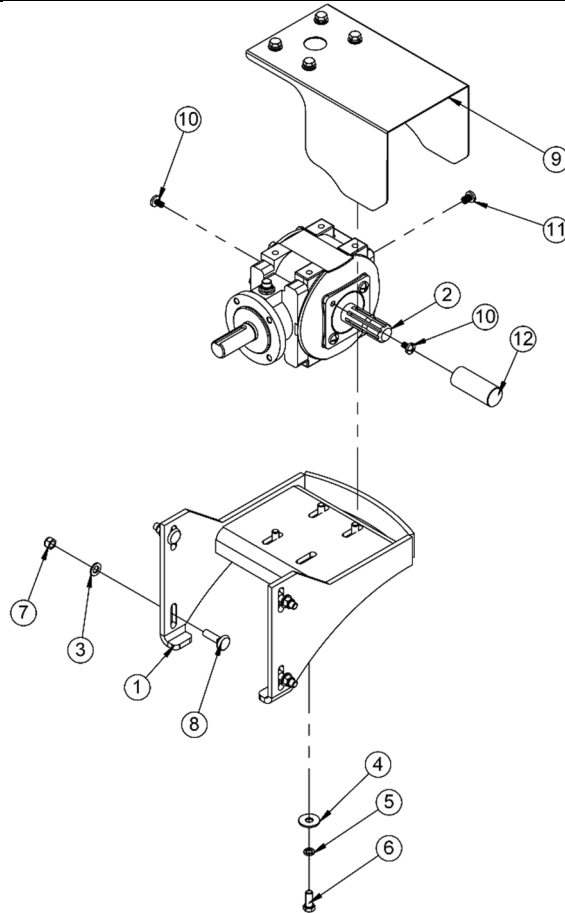

Gearbox drive shaft (steel) parts list:

POS.	COD.	Specification	Description	Steel
1	2020000295	R02001A06100-000	Gearbox mounting plate	1
2	3160100694	KF050R300Z0300	Gear box	1
3	3080100007	GB/T95-12-EP•Zn	Plain washer	4
4	3080200010	GB/T96.2-12-EP•Zn	Large plain washer	4
5	3080500009	GB/T93-12-EP•Zn	Spring washer	4
6	3040100067	GB/T5783-M12×30-8.8-EP•Zn	Full-thread hex. bolts	4
7	3050500007	GB/T889.1-M12-8-EP•Zn	Locknut	4
8	3041700008	GB/T794-M12×45-8.8-EP•Zn	Square neck bolt	4

POS.	COD.	Specification	Description	Steel
9	2060205017	R02001A06200-000	PTO safety cover assembly	1
10	3210200605	M10×16	Pipe Plug	8
11	3210200606	M12×16	Pipe Plug	4
12	3210500603	Φ35×90	Rubber	1

SIDE DRIVE ASSEMBLY

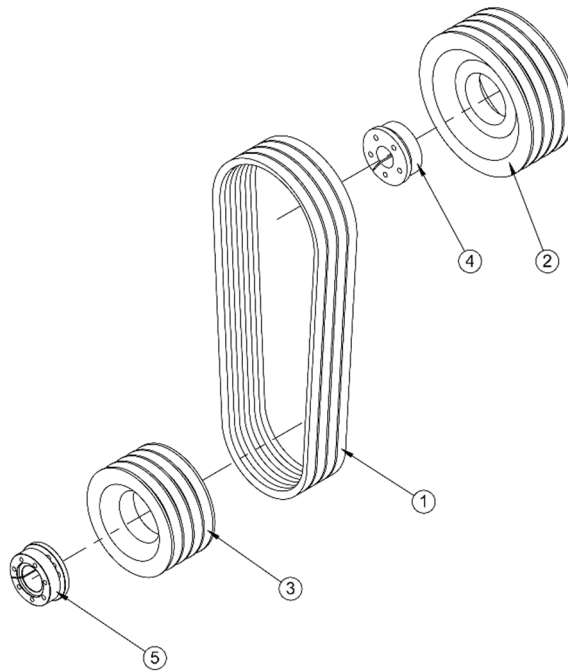

Side drive assembly options list:

COD.	Specification	Description	Note
2060105936	Side drive assembly(Neutral)	R02001A07000-000	Option
2060106208	Side drive assembly(Gates)	R02001B07000-000	Option

Side drive assembly parts list:

POS.	COD.	Specification	Description	Neutral	Gates
1	3160300014	GB/T11544-BX1295.4	Belt	4	-
1	3160300006	GATES-XPB1315	Belt	-	4
2	3160400029	SPB213-4-1-80-HT200-O	Pulley	1	1
3	3160400030	SPB159-4-1-80-HT200-O	Pulley	1	1
4	3160500005	Z6-33×80	Expanding sleeve	1	1

POS.	COD.	Specification	Description	Neutral	Gates
5	3160500007	Z6-40×80	Expanding sleeve	1	1

SIDE SHIELD ASSEMBLY

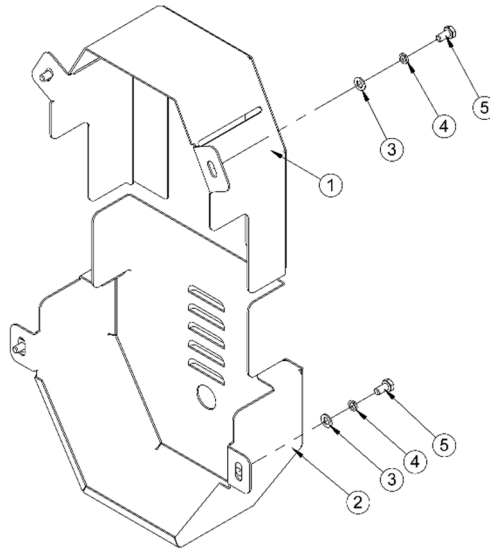

Side drive assembly parts list:

POS.	COD.	Specification	Description	QTY
1	2020000296	R02001A08100-000	Belt shield welded parts-Upper	1
2	2020000297	R02001A08200-000	Belt shield welded parts-Lower	1
3	3080100004	GB/T95-8-EP•Zn	Plain washer	4
4	3080500007	GB/T93-8-EP•Zn	Spring washer	4
5	3040100021	GB/T5783-M8×16-8.8	Full-thread hex. bolts	4

SUSPENSION ASSEMBLY

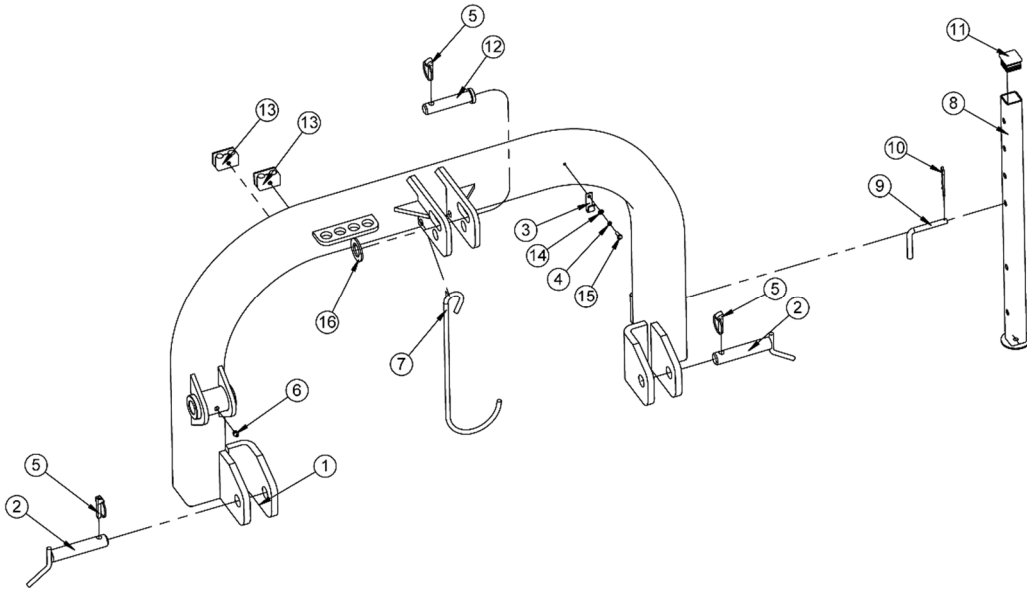

POS.	COD.	Specification	Description	QTY
1	2020000309	R02001A09100-000	Suspension frame	1
2	2020000221	R02001A09200-000	Lower suspension pin	2
3	3220400602	G02001A12000-001	Spring clasp	1
4	3080500006	GB/T93-6-EP•Zn	Spring washer	1
5	3120400007	GB/T4329-12-EP•Zn	Pin	3
6	3170400004	JB/T7940.1-M10×1 304	Grease nipple	1
7	2010000028	W01006A01000-002	PTO shaft hook	1
8	2020000089	R02001A09300-000	Right sealing plate	1
9	2010000017	G01001A16000-001	Rake pin	1
10	3120400008	Din11024-4-EP•Zn	R Pin	1
11	3210200004	41×41	Square pipe plug	1
12	3120500021	MT95019	Pin	1
13	3210100005	2-Φ16	Pipe clamp	2
14	3080100003	GB/T95-6-EP•Zn	Plain washer	1
15	3040100005	GB/T5783-M6×16-8.8-EP•Zn	Full-thread hex. bolts	1
16	3080100015	GB/T95-30-EP•Zn	Plain washer	1

PROTECTION COMPONENT

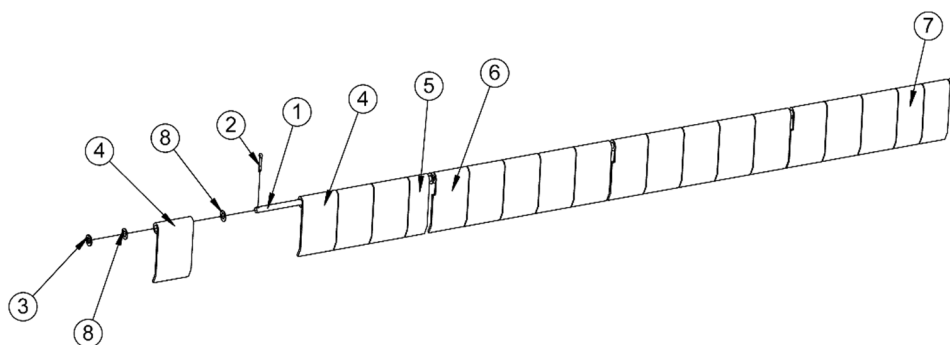

Protection component options list:

COD.	Specification	Description	Model
2060105942	R02001A10000-000	Protection component	ME-VFLMO54/54T
2060105943	R02002A10000-000	Protection component	ME-VFLMO64/64T
2060105944	R02003A10000-000	Protection component	ME-VFLMO72/72T
2060105945	R02004A10000-000	Protection component	ME-VFLMO78/78T
2060105946	R02005A10000-000	Protection component	ME-VFLMO86/86T

Protection component parts list:

POS.	COD.	Specification	Description	54(T)/ QTY	64(T)/ QTY	72(T)/ QTY	78(T)/ QTY	86(T)/ QTY
1	2010000094	R02001A10000-001	Baffle shaft	1	-	-	-	-
1	2010000095	R02002A10000-001	Baffle shaft	-	1	-	-	-
1	2010000096	R02003A10000-001	Baffle shaft	-	-	1	-	-
1	2010000097	R02004A10000-001	Baffle shaft	-	-	-	1	-
1	2010000098	R02005A10000-001	Baffle shaft	-	-	-	-	1
2	3120100091	GB/T91-4×25	Split pin	2	2	2	2	2
3	3080100006	GB/T95-10-EP•Zn	Plain washer	2	2	2	2	2
4	2000000018	G03001A15000-002	Baffle	14	16	18	22	25
5	2000000795	G03001A15000-005	Baffle	1	2	-	1	2
6	2000000016	G03001A15000-003	Notched baffle	3	4	5	4	4
7	2000000017	G03001A15000-004	Baffle	2	1	5	1	-
8	3080100005	GB/T95-10-EP•Zn-1	Plain washer	21	23	27	27	30

SWING ASSEMBLY

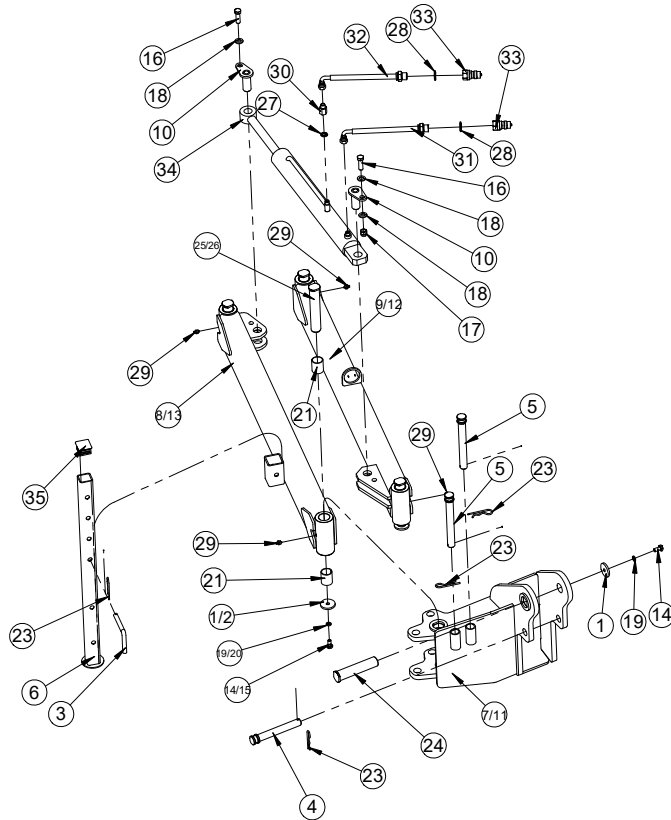

Swing assembly parts list:

POS.	COD.	Specification	Description	QTY.
1	200000125	G05001A25000-007	Washer	5
2	2000004922	R02013A11000-005	Washer	-
3	2010000017	G01001A16000-001	Rake pin	1
4	2010000099	R02001A11000-002	Pin shaft	1
5	2010000100	R02001A11000-003	Pin shaft	2
6	2020000089	R02001A09300-000	Welded parts of right sealing plate	1
7	2020000310	R02001A11100-000	Welding fittings of lifting frame	1
8	2020000325	R02001A11200-000	Welding of connecting pipe	1
9	2020000326	R02001A11300-000	Welding of connecting pipe	1
10	2020000327	R02001A11400-000	Pin welded parts	2
11	2020005014	R02013A11100-000	Lifting frame welding	-
12	2020005015	R02013A11300-000	Welding of connecting pipe	-

POS.	COD.	Specification	Description	QTY.
13	2020005016	R02013A11200-000	Welding of connecting pipe	-
14	3040100041	GB/T5783-M10×20-8.8-EP•Zn	Full-thread hex. bolts	5
15	3040100064	GB/T5783-M12×20-8.8-EP•Zn	Full-thread hex. bolts	-
16	3040100071	GB/T5783-M12×40-8.8-EP•Zn	Full-thread hex. bolts	2
17	3050500007	GB/T889.1-M12-8-EP•Zn	Locknut	2
18	3080100007	GB/T95-12-EP•Zn	Plain washer	4
19	3080500008	GB/T93-10-EP•Zn	Spring washer	5
20	3080500009	GB/T93-12-EP•Zn	Spring washer	-
21	3100900007	SF-2-30×34×40	Bushings	8
22	3100900009	SF-2-40×44×50	Bushings	-
23	3120400008	Din11024-4-EP•Zn	R Pin	4
24	3120500001	R02001A11000-004	Pin	1
25	3120500002	R02001A11000-001	Pin	4
26	3120500602	R02013A11000-001	Pin	-
27	3170300001	BS/A-13.7×20.6×2-Q235	Combined sealing gaskets	1
28	3170300006	BS/A-21.5×28.6×2.5-Q235	Combined sealing gaskets	2
29	3170400004	JB/T7940.1-M10×1 304	Grease nipple	4
30	3180100001	K4-GAI04R1/4XCF-Φ2	Transition joints	1
31	3180200035	2SN06BL×M10610-04-08/M20593-04-04×2000	Hose	1
32	3180200036	2SN06BL×M10610-04-08/M20593-04-04×2150	Hose	1
33	3180500001	Q00211041A-08-08	Hollow bolt	2
34	3181300013	CDL1MP5-50/25/400-D-G1/4-2CGUM-black	Hydraulic cylinder	1
35	3210200004	41×41	Square pipe plug	1

ROLLOVER ASSEMBLY

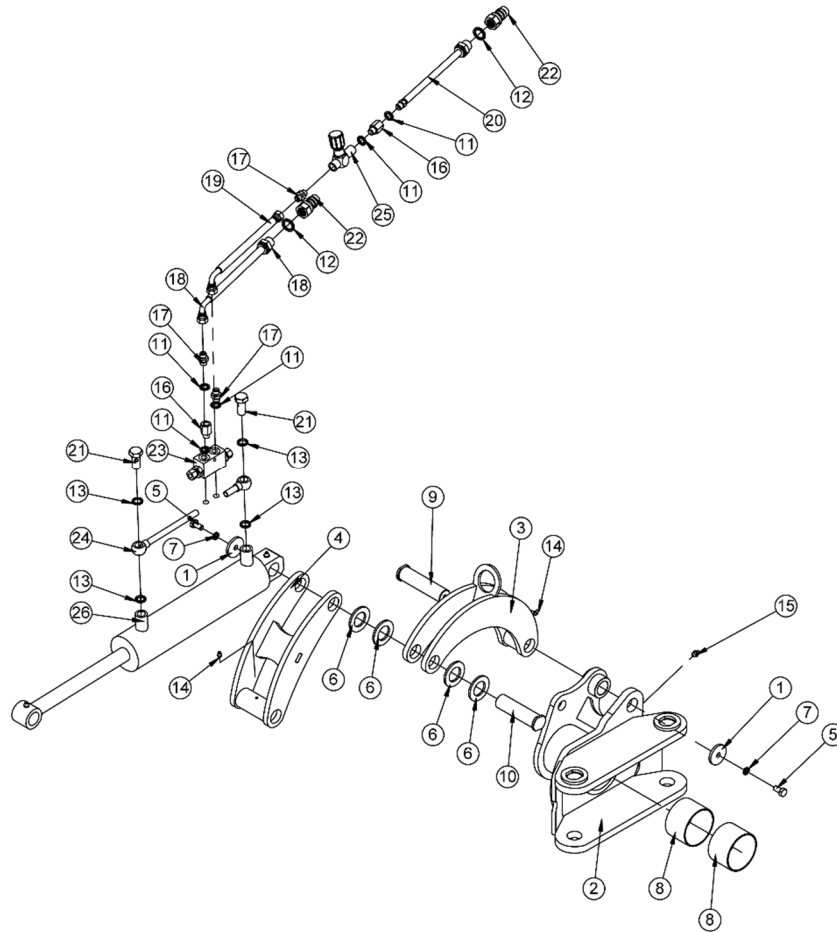

Rollover assembly parts list:

POS.	COD.	Specification	Description	QTY.
1	200000125	G05001A25000-007	Washer	2
2	202000306	R02001A12100-000	Reverse frame welding	1
2	2020005013	R02013A12100-000	Reverse frame welding	-
3	202000307	R02001A12200-000	Connecting weldment	1
4	202000308	R02001A12300-000	Connecting weldment	1
5	3040100041	GB/T5783-M10×20-8.8	Full-thread hex. bolts	2
6	3080100015	GB/T95-30-EP•Zn	Plain washer	4
7	3080500008	GB/T93-10-EP•Zn	Spring washer	2
8	3100900014	SF-2-80×85×55	Bushings	2
9	3120500003	R02001A12000-002	Pin	1

POS.	COD.	Specification	Description	QTY.
10	3120500005	R02001A12000-001	Pin	1
11	3170300001	BS/A-13.7×20.6×2-Q235	Combined sealing gaskets	5
12	3170300006	BS/A-21.5×28.6×2.5-Q235	Combined sealing gaskets	2
13	3170300012	BS-16.4×22×25-Q235	Combined sealing gaskets	4
14	3170400002	JB/T7940.1-M6 304	Grease nipple	2
15	3170400004	JB/T7940.1-M10×1 304	Grease nipple	1
16	3180100001	K4-GAI04R1/4XCF-Φ2	Transition joints	2
17	3180100028	K4-GE04R1/4EDOMDCF	Transition joints	3
18	3180200037	2SN06BL×M10610-04-08/M20592-04-04×3680	Hose	1
19	3180200063	2SN06BL×M20513-04-04/M20593-04-04×2100	Hose	1
20	3180200064	2SN06BL×M10610-04-04/M10610-04-08×1500	Hose	1
21	3180300007	M16×1.5-35-8-25	Hollow bolt	2
22	3180500001	Q00211041A-08-08	Hollow bolt	2
23	3180700009	QT15312	Double hydraulic locks	1
24	3180700017	BCRI200-056	Hydraulic lock assembly	1
25	3180700018	STU.G14	Hydraulic Valve	1
26	3181300012	CDL1MP5-63/30/262-D-M16x1.5-1CGUM-Black	Hydraulic cylinder	1

ORDINARY AXLE + BLADES

Ordinary axle + hammer blades

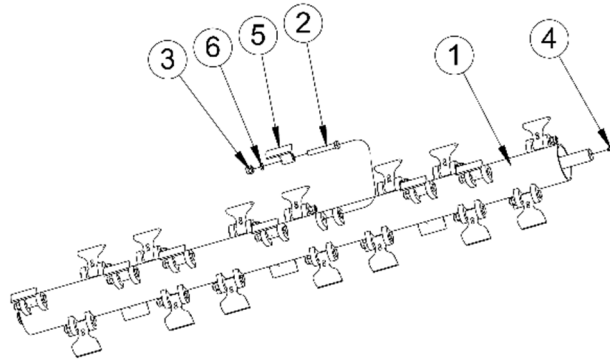

Ordinary Axle +hammer blade options list:

COD.	Specification	Description	Model	Note
2090000178	R02001A02000-000	Ordinary Axle +hammer blade	ME-VFLMO54(T)	Option
2090000173	R02001B02000-000	Ordinary Axle +Y blade		
2090000179	R02002A02000-000	Ordinary Axle +hammer blade	ME-VFLMO64(T)	Option
2090000174	R02002B02000-000	Ordinary Axle +Y blade		
2090000180	R02003A02000-000	Ordinary Axle +hammer blade	ME-VFLMO72(T)	Option
2090000175	R02003B02000-000	Ordinary Axle +Y blade		
2090000181	R02004A02000-000	Ordinary Axle +hammer blade	ME-VFLMO78(T)	Option
2090000176	R02004B02000-000	Ordinary Axle +Y blade		
2090000182	R02005A02000-000	Ordinary Axle +hammer blade	ME-VFLMO86(T)	Option
2090000177	R02005B02000-000	Ordinary Axle +Y blade		

Ordinary Axle +hammer blade parts list:

POS.	COD.	Specification	Description	54(T)/ QTY	64(T)/ QTY	72(T)/ QTY	78(T)/ QTY	86(T)/ QTY
1	2020000299	R02001A02100-000	Cutter shaft	1	-	-	-	-
1	2020000300	R02002A02100-000	Cutter shaft	-	1	-	-	-
1	2020000301	R02003A02100-000	Cutter shaft	-	-	1	-	-
1	2020000302	R02004A02100-000	Cutter shaft	-	-	-	1	-
1	2020000303	R02005A02100-000	Cutter shaft	-	-	-	-	1
2	3040300064	GB/T5782-M16×100-10.9	Hex. head bolts	18	22	24	28	32

POS.	COD.	Specification	Description	54(T)/ QTY	64(T)/ QTY	72(T)/ QTY	78(T)/ QTY	86(T)/ QTY
3	3050500009	GB/T889.1-M16-8-EP•Zn	Locknut	18	22	24	28	32
4	3170400003	JB/T7940.1-M8×1 304	Grease nipple	1	1	1	1	1
5	3220100060	MT01001	Blade	18	22	24	28	32
6	3080500011	GB/T93-16-EP•Zn	Spring washer	18	22	24	28	32

Ordinary axle +Y-type blades

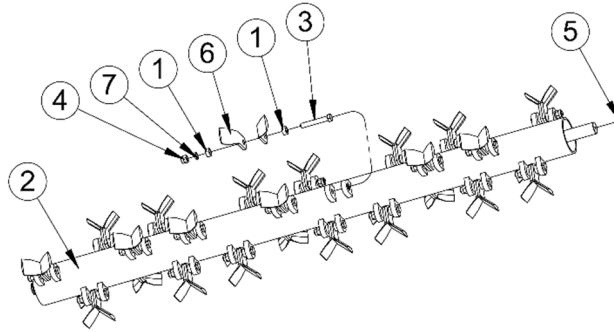

Ordinary Axle +Y type blade parts list:

POS.	COD.	Specification	Description	54(T)/ QTY	64(T)/ QTY	72(T)/ QTY	78(T)/ QTY	86(T)/ QTY
1	2010000001	G01001A02200-001	Blade spacer	36	44	48	56	64
2	2020000299	R02001A02100-000	Cutter shaft	1	-	-	-	-
2	2020000300	R02002A02100-000	Cutter shaft	-	1	-	-	-
2	2020000301	R02003A02100-000	Cutter shaft	-	-	1	-	-
2	2020000302	R02004A02100-000	Cutter shaft	-	-	-	1	-
2	2020000303	R02005A02100-000	Cutter shaft	-	-	-	-	1
3	3040300064	GB/T5782-M16×100-10.9-O	Hex. head bolts	18	22	24	28	32
4	3050500009	GB/T889.1-M16-8-EP•Zn	Locknut	18	22	24	28	32
5	3170400003	JB/T7940.1-M8×1 304	Grease nipple	1	1	1	1	1
6	3220100045	MT02001	Blade	36	44	48	56	64
7	3080500011	GB/T93-16-EP•Zn	Spring washer	18	22	24	28	32

