

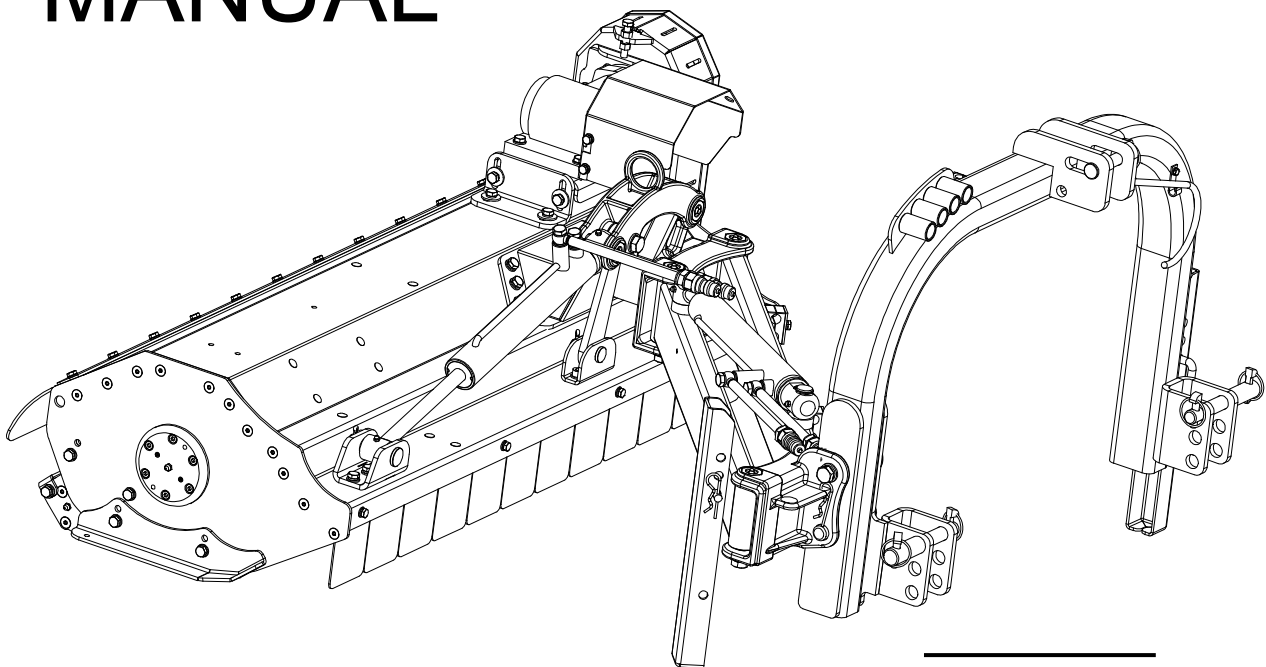

Flail Mower

OPERATOR'S MANUAL



ME-VS40
ME-VS48
ME-VS58
ME-VS64



instructions. Failure to comply with the warnings and precautions may result in serious injury or death.

Table of Content

SAFETY PRECAUTIONS	3
<i>Safety First</i>	3
<i>Safety Alert Symbol</i>	4
<i>Safety for Children</i>	4
<i>Operation Safety</i>	5
Tractor Shutdown Safety	5
Use A Safety Chain.....	5
Transport Safely.....	6
Avoid Crystalline Silica (Quartz) Dust	6
Avoid Contact Blades.....	7
<i>Maintenance Safety</i>	7
Preparation Before Maintenance	8
Personal Protective Equipment	8
Keep Riders Off Machinery.....	9
Safety Lights and Devices	9
Seat Belt and ROPS.....	9
High Pressure Fluids Safety.....	9
Handle Chemicals Properly.....	10
Tire Maintenance Safety.....	10
<i>Storage and Disposal Safety</i>	11
Storage Safety.....	11
Disposal Safety	11
<i>Safety Labels</i>	11
<i>Labels Location</i>	12
PRODUCT INTRODUCTION.....	13
<i>Technical Date</i>	15
<i>Implement Identification</i>	17
UNPACKING.....	18
ASSEMBLY	19

Tractor Hook-up	21
Driveline Installation	22
Driveline length check	23
Customize driveline	24
Driveline interference check.....	24
OPERATION	25
Checklist before Operation	26
Adjusting Roller/Skid Height	27
Adjusting the Belt	28
Starting the Machine	29
SERVICE AND MAINTENANCE	30
General Service	30
Gearbox Maintenance	30
PTO Shaft Maintenance	30
Lubrication Parts	31
Tightening Torque	33
Replacing the Blade	34
STORAGE AND TRANSPORT	35
Storage	35
Transport	35
TROUBLESHOOTING	36
EXPLODED VIEWS & PARTS LIST	38
WARRANTY	68

SAFETY PRECAUTIONS

Listed below are common practices that may or may not be applicable to the products described in this manual.

Safety First

Careful operation is your best assurance against an accident. Please be fully aware that you are responsible for the safe operation and maintenance of your implement. You must ensure that you and anyone else who is going to operate, maintain or work around the implement is familiar with the operating and maintenance procedures and related safe information contained in this manual. This manual is prepared to guide you through all essential operations related to this implement and alert you to all good safety practices that should be strictly followed.

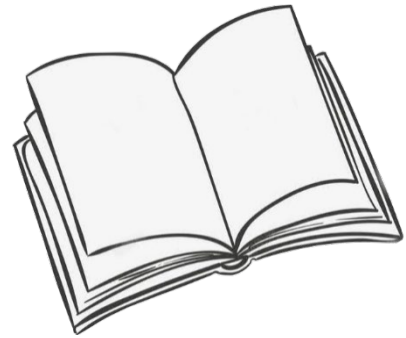

Please constantly bear in mind that good safety practices not only protect you but also the people around you. Incorporate these practices an inseparable part into your safety program. Make sure that who operates this equipment is familiar with the recommended operating and maintenance procedures and follows all the safety precautions. Most accidents can be prevented. Do not risk injury of death by ignoring good safety practices.

- Thoroughly read and understand the “[Safety Labels](#)” section. Read all instructions noted on them.
- Do not operate the equipment while under the influence of drugs or alcohol, as they impair your ability to safely and properly operate the equipment.
- The operator should be familiar with all functions of the tractor and attached implement, and be able to handle emergencies quickly.
- Make sure all guards and shields appropriate for the operation are in place and secured before operating the implement.
- Keep all bystanders away from equipment and work area. Start tractor from the driver’s seat with hydraulic controls in neutral.
- Operate tractor and controls from the driver’s seat only.
- Never dismount from a moving tractor or leave tractor unattended with engine running.
- Do not allow anyone to stand between the implement and tractor while backing up to the implement.
- Keep hands, feet, and clothing away from power-driven parts.
- While transporting and operating equipment, watch out for objects overhead and along the

sides such as fences, trees, buildings, wires, etc.

- Do not turn tractor so tight as to cause hitched implement to ride up on the tractor's rear wheel.
- Store implement in a safe and secure area where children normally do not play. When needed, secure implement against falling with support blocks.

Safety Alert Symbol

The SAFETY ALERT SYMBOL indicates there is a potential hazard to personal safety and extra precaution must be taken. When you see this symbol, be alert and carefully read the message that follows it. Hazard control, and accident prevention are dependent upon the awareness, concern, prudence, and proper training of personnel involved in the operation, transport, maintenance, and storage of equipment.

Be Aware of Signal Words

A signal word designates a degree or level of hazard seriousness. They are:

⚠ DANGER: Indicates a hazardous situation that, if not avoided, will result in death or serious injury.

⚠ WARNING: Indicates a hazardous situation that, if not avoided, could result in death or serious injury.

⚠ CAUTION: Indicates a hazardous situation that, if not avoided, may result in minor or moderate injury.

Be Aware of Special Notices

Special notices are intended to point out important and helpful information that should be followed. They are:

ATTENTION: Indicates that equipment or property damage could result if instructions are not followed.

NOTE: Indicates supplementary explanations that will be helpful when using the equipment.

Safety for Children

Tragedy can occur if the operator is not alert to the presence of children, Children generally are attracted to implements and their work.

- Never assume children will remain where you last saw them.
- Keep children out of the work area and under the watchful eye of a responsible adult.
- Be alert and shut the implement and tractor down if children enter the work area.
- Never carry children on the tractor or implement. There is not a safe place for them to ride. They may fall off and be run over or interfere with the control of the power machine.
- Never allow children to operate the power machine, even under adult supervision.
- Never allow children to play on the power machine or implement.

Operation Safety

Use extra caution when backing up. Before the tractor starts to move, look down and behind to make sure the area is safety and clear.

Tractor Shutdown Safety

If engaged, disengage power take-off.

Park on solid, level ground and lower implement to ground or onto support blocks.

- Put tractor in park or set park brake.
- Turn off engine and remove ignition key to prevent unauthorized starting.
- Relieve all hydraulic pressure to auxiliary hydraulic lines.
- Wait for all components to stop before leaving operator's seat.
- Use steps, grab-handles and anti-slip surfaces when stepping on or off the tractor.
- If engaged, disengage power take-off.
- Park on solid, level ground and lower implement to ground or onto support blocks.
- Put tractor in park or set park brake.
- Turn off engine and remove ignition key to prevent unauthorized starting.
- Relieve all hydraulic pressure to auxiliary hydraulic lines.
- Wait for all components to stop before leaving operator's seat.
- Use steps, grab-handles and anti-slip surfaces when stepping on and off the tractor.

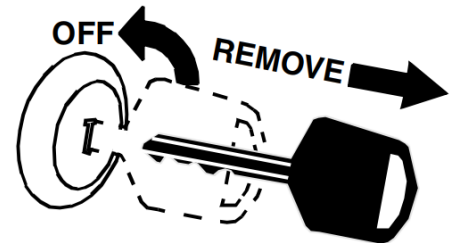

Use A Safety Chain

A safety chain will help control drawn machinery should it separate from the tractor drawbar.

Use a chain with the strength rating equal to or greater than the gross weight of the towed implement.

- Attach the chain to the tractor drawbar support or other specified anchor location. Allow only enough slack in the chain to permit turning.
- Always hitch the implement to the machine towing it. Do not use the safety chain to tow the implement.



Transport Safely

- Comply with federal, state, and local laws.
- Avoid contact with any overhead utility lines or electrically charged conductors.
- Engage park brake when stopped on an incline.
- Maximum transport speed for an implement is 30 km/h. DO NOT EXCEED.
- Never travel at a speed which does not allow adequate control of steering and stopping. Some rough terrains require a slower speed. Sudden braking can cause a towed load to swerve and upset.
- Do not tow an implement that, when fully loaded, weights more than 1.5 times the weight of towing vehicle.

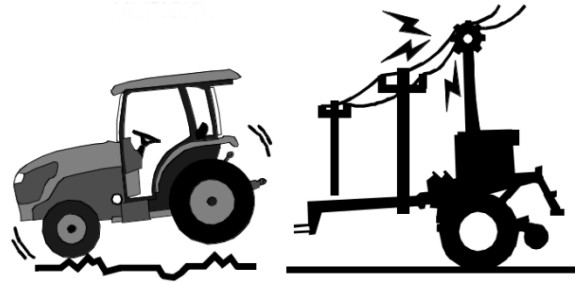

Avoid Crystalline Silica (Quartz) Dust

Because crystalline silica is a basic component of sand and granite, many activities at construction sites produce dust containing crystalline silica. Trenching, sawing, and boring of material containing crystalline silica can produce dust containing crystalline silica particles. This dust can cause serious injury to the lungs (silicosis). There are guidelines which should be followed if crystalline silica (quartz) is present in the dust.

- Be aware of and follow OSHA (or other local, State, or Federal) guidelines for exposure to airborne crystalline silica.
- Know the work operations where exposure to crystalline silica may occur.
- Participate in air monitoring or training programs offered by the employer.
- Be aware of and use optional equipment controls such as water sprays, local exhaust ventilation, and enclosed cabs with positive pressure air conditioning if the machine has such equipment. Otherwise respirators shall be worn.
- Where respirators are required, wear a respirator approved for protection against crystalline silica containing dust. Do not alter respirator in any way. Workers who use tight-fitting respirators can not have beards/ mustaches which interfere with the respirator seal to the face.
- If possible, change into disposable or washable work clothes at the work site; shower and change into clean clothing before leaving the work site.
- Do not eat, drink, use tobacco products, or apply cosmetics in areas where there is dust



containing crystalline silica.

- Store food, drink, and personal belongings away from the work area.
- Wash hands and face before eating, drinking, smoking, or applying cosmetics after leaving the exposure area.

Avoid Contact Blades

Keep away from rotating blades to avoid death or serious injury from blade contact.

- Stay away and keep hands, feet and body away from rotating blades, drivelines and parts until all moving elements have stopped.
- Do not put hands or feet under mower hood.
- Stop rotating blades disengage PTO and wait for blade to stop rotating before raising mower hood or swings.
- Stop look and listen before approaching the mower to make sure all rotating motion has stopped.
- If a material blockage occurs in the inlet or discharge areas of the mower, shut down tractor engine, disengage the PTO and wait for all rotating motions to stop. Place the tractor in park position, engage the parking brake and remove the key before leaving the operator's seat. Clear the blockage before processing with mowing. Be sure to keep feet and hands clear of the mower blades. If you raise the mower or swing to access the blockage, engage the swing lock up latch and securely block up the mower before placing any parts of the body beneath the mower.

Maintenance Safety

- Good maintenance is your responsibility. Poor maintenance is an invitation to trouble.
- Follow good shop practices.
- Keep service area clean and dry.
- Be sure electrical outlets and tools are properly grounded.
- Use adequate light for the job at hand.
- Make sure there is plenty of ventilation. Never operate the engine of the tractor in a closed area. The exhaust gas may cause healthy problem.
- Before maintenance, shut off the tractor (See [Tractor Shutdown Procedure](#)).
- Allow equipment to cool before maintenance operation.
- Never work under the machine unless it is secured by a mechanical stand.
- Use personal protection devices such as safety goggles, hand gloves and hearing protectors, when performing any service or maintenance work. Use heavy gloves when handling blades.

- Only use original parts for service and maintenance.
- A fire extinguisher and first aid kit should be kept readily accessible while performing maintenance on this equipment.
- Periodically tighten all bolts, nuts and screws and check that all pins are properly installed to ensure unit is in a safe condition.
- Do not weld or torch on galvanized metal as it will release toxic fumes.
- Always make sure any material and waste products from the repair and maintenance of the implement are properly collected and disposed.
- Disconnect battery (If the implement has the battery) ground cable (-) before servicing or adjusting electrical systems or before welding on implement.
- Do not grease or oil implement while it is in operation.
- Do not work under any hydraulically supported equipment. It can settle, suddenly leak down, or be lowered accidentally. If it is necessary to work under the equipment, securely support it with stands or suitable blocking beforehand.
- When completing a maintenance or service function, make sure all safety shields and devices are installed before placing machine in service.

Preparation Before Maintenance

- Be prepared if a fire starts.
- Keep a first aid kit and fire extinguisher handy.
- Keep emergency numbers for ambulance, hospital and fire department near the working area.

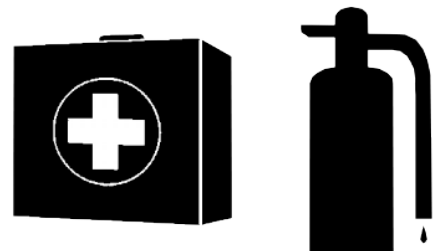

Personal Protective Equipment

- Wear protective clothing and equipment appropriate for the job such as safety shoes, safety glasses, hard hat, dust mask, and ear plugs.
- Clothing should fit snug without fringes and pull strings to avoid entanglement with moving parts.
- Prolonged exposure to loud noise can cause hearing impairment or hearing loss. Wear suitable hearing protection such as earmuffs or earplugs.
- Operating a machine safely requires the operator's full attention. Avoid wearing headphones while operating equipment.



Keep Riders Off Machinery

- Never carry riders on the tractor or implement.
- Riders obstruct operator's view and interfere with the control of the power machine.
- Riders can be struck by objects or thrown from the equipment.
- Never use the tractor or implement to lift or transport riders.

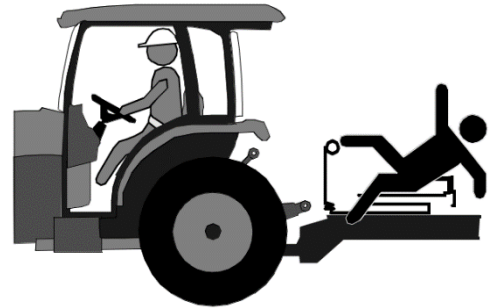

Safety Lights and Devices

- A slow moving power machine can create a hazard when driven on public roads. They are difficult to see, especially at night.
- Flashing warning lights and turn signals are recommended whenever driving on public roads.
- For tractors and other agriculture equipment, a Slow Moving Vehicle (SMV) sign is required when traveling on public roads.

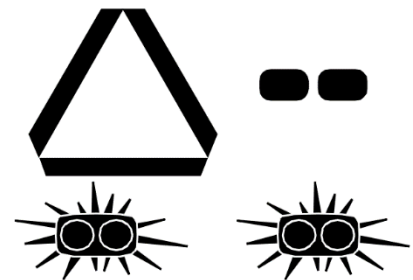

Seat Belt and ROPS

- We recommends the use of a CAB or roll-over-protective structures (ROPS) and seat belt in almost all power machines. Combination of a CAB or ROPS and seat belt will reduce the risk of serious injury or death if the power machine should be upset.
- If ROPS is in the locked-up position, fasten seat belt snugly and securely to help protect against serious injury or death from falling and machine overturn.



High Pressure Fluids Safety

- Escaping fluid under pressure will penetrate the skin or eyes causing serious injury.

- Relieve all residual pressure before disconnecting hydraulic lines or performing work on the hydraulic system.
- Make sure all hydraulic fluid connections are properly tightened/torqued and all hydraulic hoses and lines are in good condition before applying pressure to the system.
- Use a piece of paper or cardboard, NOT BODY PARTS, to check for suspected leaks.
- Wear protective gloves and safety glasses or goggles when working with hydraulic systems.
- DO NOT DELAY. If an accident occurs, seek immediate emergency medical care or gangrene may result.



Handle Chemicals Properly

- Protective clothing should be worn.
- Handle all chemicals with care.
- Follow instructions on container label.
- Agricultural chemicals can be dangerous. Improper use can seriously injure persons, animals, plants, soil, and property.
- Inhaling smoke from any type of chemical fire can be a serious health hazard.
- Store or dispose of unused chemicals as specified by the chemical manufacturer.



Tire Maintenance Safety

- Tire changing can be dangerous and must be performed by trained personnel using the correct tools and equipment.
- Always properly match the wheel size to the properly sized tire.
- Always maintain correct tire pressure. Do not inflate tires above recommended pressures shown in the Operator's Manual.
- When inflating tires, use a clip-on chuck and extension hose long enough to allow you to stand to one side and NOT in front of or over the tire assembly. Use a safety cage if available.
- Securely support the implement when changing a wheel.
- When removing and installing wheels, use wheel handling equipment adequate for the weight involved.



- Make sure wheel bolts have been tightened to the specified torque.

Storage and Disposal Safety

Storage Safety

1. Store the machine in an area away from human activity. Do not keep the machine out of the children's reach. Do not permit children to play on or around the stored machine.
2. Store the machine in a dry, level area.
3. Clean grease and oil as required and protect it from the elements.

Disposal Safety

1. Improper disposal of oil or other waste may be hazardous to the environment.
2. When oil is emptied from the machine, it must be poured into a leak-proof container suitable for oil. It is not permissible to store oil in a container used for food or drink, in order to avoid the oil being consumed by mistake and causing serious injury. It is prohibited to spill oil on the ground, or pour it into a drain or anywhere leading to a water source.
3. Discarded oil, fuel, coolant, brake fluid, filters and batteries may not be thrown away or emptied in just any way. Contact your local authority for further information.

Safety Labels

Your implement comes equipped with all safety labels in place. They were designed to help you safely operate your implement. Read and follow their directions.

1. Keep all safety labels clean and legible.
2. Replace all damaged or missing labels.
3. When ordering new components make sure the correct safety labels are included in the request.
4. Refer to steps below for proper label placement.
 - a) Clean surface area where label is to be placed.
 - b) Spray soapy water onto the cleaned area.
 - c) Peel backing from label and press label firmly onto the surface.
 - d) Squeeze out air bubbles with edge of a card or with a similar type of straight edge.

Labels Location

Labels locations below are common practices of the machine that may or may not be applicable to the products described in this manual

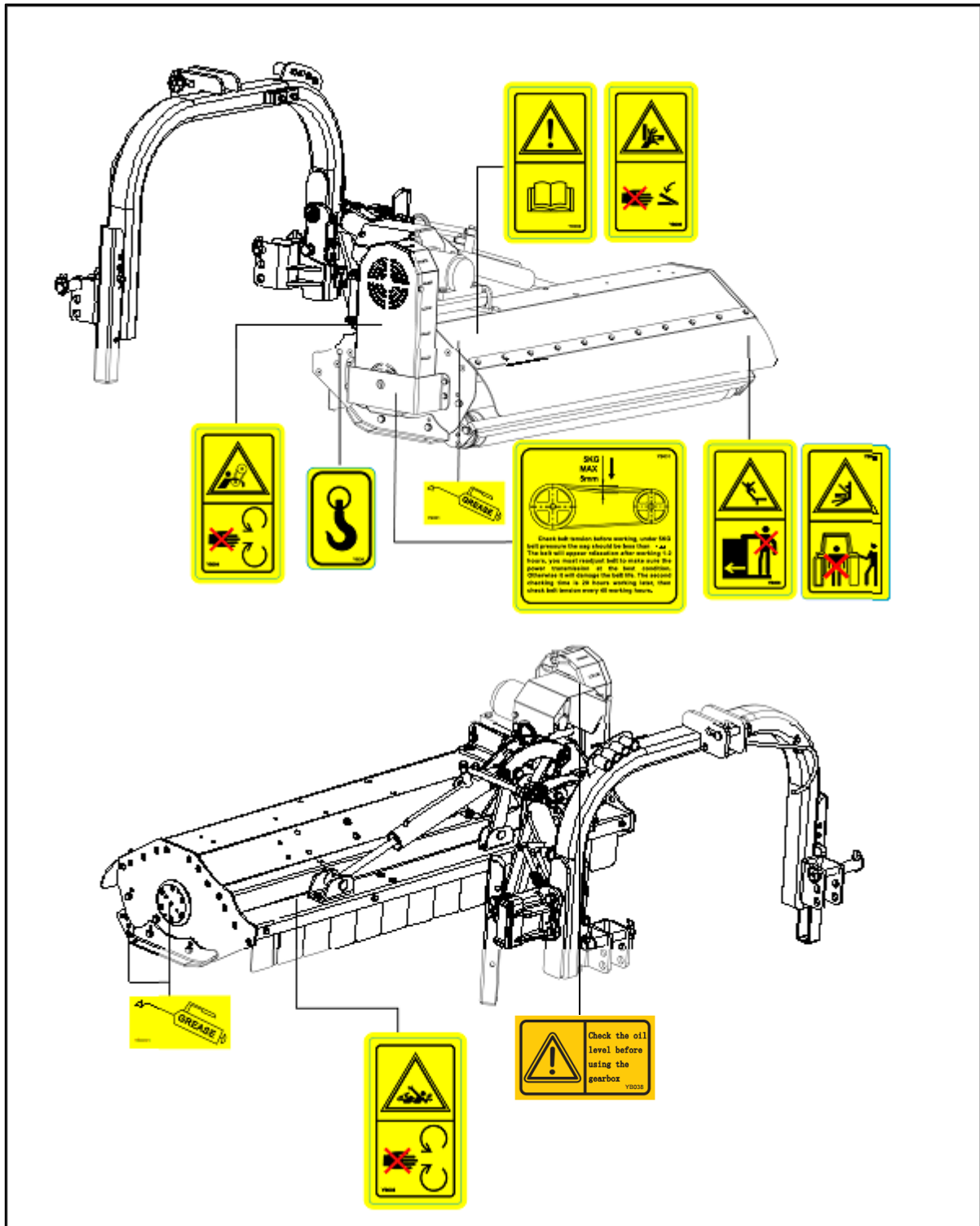

PRODUCT INTRODUCTION

Listed figure is common mower of ME-VS48 that may or may not be applicable to the products described in this manual.

See Figure 1

Mowers are used for pasture clipping, crop residue shredding, heavy brush cutting, waterways, right-of-ways, roadside or highway mowing. Also, these mowers are used for cutting grass and other growth in public areas such as parks and cemeteries. Proper assembly, maintenance, and safe operating practices will help you get years of satisfactory use from this machine.

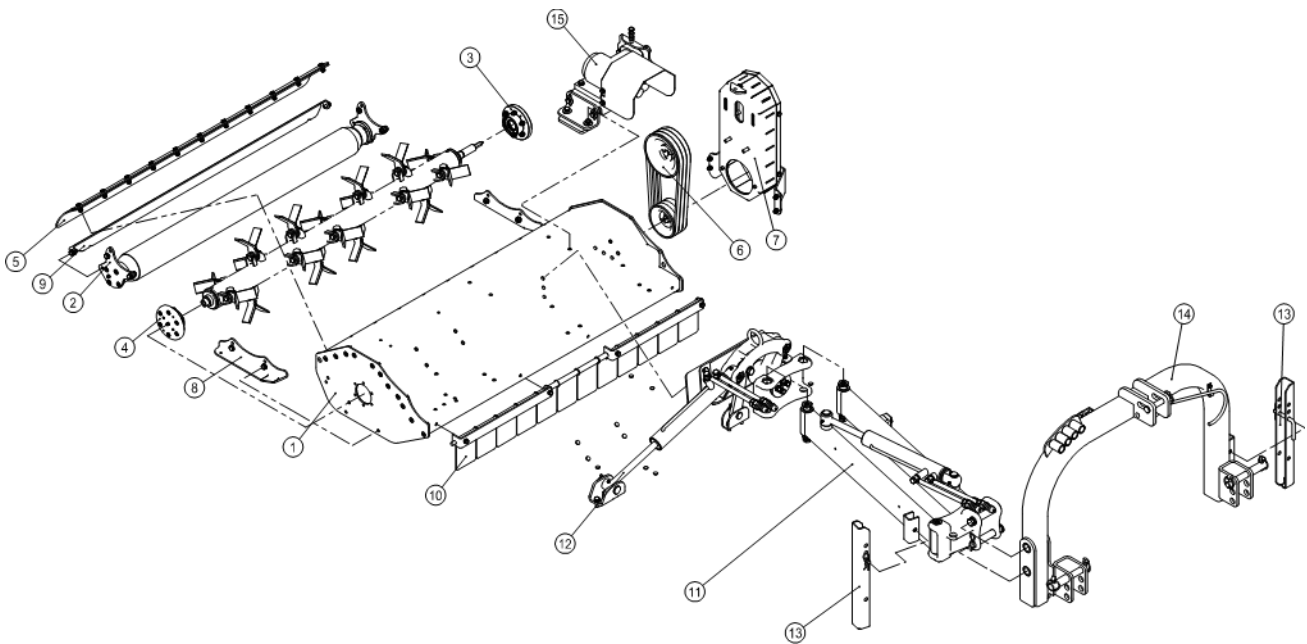

Figure 1





Main parts name and function list:



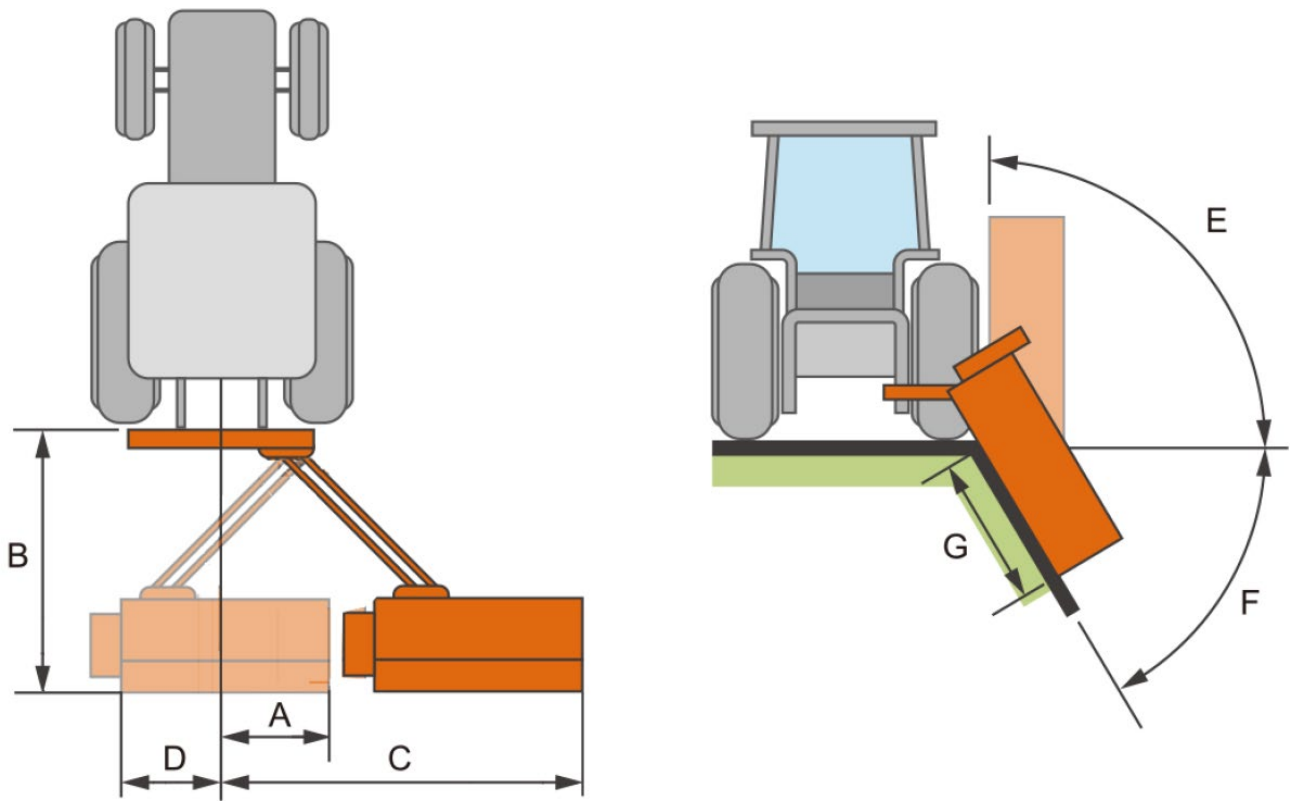



Item	Name	Functional Description
1	Hood assembly	Protecting people from harm during cutting procedure.
2	Roller assembly	Its role is to flatten the chopped material, usually the drum is also set with several height adjustments, through the drum height adjustment can achieve different mowing stubble height and grass discharge efficiency adjustment.
3/4	Blade shaft bearing seat assembly	It supports the work of the cutter shaft

Item	Name	Functional Description
5	Covering plate assembly	Prevent the Bits of grass or rocks from being thrown out.
6	Side driveline	Transfer power generated by the engine to cutter shaft
7	Side shield assembly	Protect the people or objects from harm of side driveline.
8	Skid plate assembly	It is used to support the machine when it is stationary, guide it when it is working, and adjust the height of the mowing up and down, while avoiding damage to the ground when the implement is working.
9	Scraper assembly	The purpose of the scraper is to remove the mud from the drum and prevent excess mud from sticking to the drum.
10	Protection component	Prevent the Bits of grass or rocks from being thrown out.
11	Swing Assembly	The mower can be moved from side to side while mowing to extend the cutting width.
12	Reverse assembly	The mower is turned horizontally and vertically by means of hydraulic cylinders for trimming the sides of bushes or hedges.
13	Supporting Assembly	It is used to support the machine when it is stationary
14	Hitch assembly	Hitch the implement to tractor via three-point hitch frame.
15	Gearbox drive	Connect the motor shaft to the gearbox. It is used to increase the output torque or change the speed (RPM) of the motor.

Technical Data

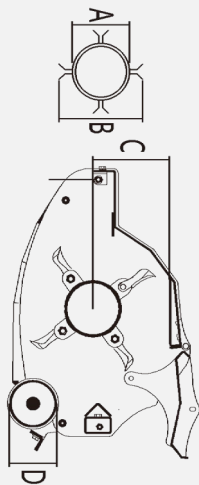

Model		ME-VS40	ME-VS48	ME-VS58	ME-VS64
A	cm	57.4	77.4	97.4	117.4
B		127.7			
C		168.9	188.9	208.9	228.9
D		47.6			
E		93°			
F		50°			
G		58.2	78.2	98.2	118.2
			105	125	145
	HP	30			
	HP	25-45			
	RPM	2092			

	N	14	18	20	24
	N	28	36	40	48
	PTO (rpm)	540			
	A mm	Φ76x8			
	B mm	Φ288			
	C mm	164			
	D mm	Φ102x5			
	Hood thickness Side panel thickness mm	4/5			
	V m/s	31.5			
	Openable maintenance door	NO			
	CAT.	CAT. I / CAT. II			
	N	3			
	Kg	250	273	289	305

Implement Identification

The identification nameplate is affixed to the frame of each implement. It contains the “CE” certification brand and information about (CE is only for European state, implement identification below is for reference): the Manufacturer, Type, Serial Number, Model Number, Weight. The nameplate (Shown in the below) is for reference only and is based on the real thing.

MATENG			
TYPE	<input type="text"/>	YEAR	<input type="text"/>
TYPE		ANNÉE	
SERIAL NO.	<input type="text"/>	WEIGHT	<input type="text"/>
N° DE SÉRIE		POIDS	
Toll Free: 1-866-718-4746			
info@mateng.ca www.mateng.ca			

UNPACKING

After unpacking, please check the components shown in **Figure 1.1**

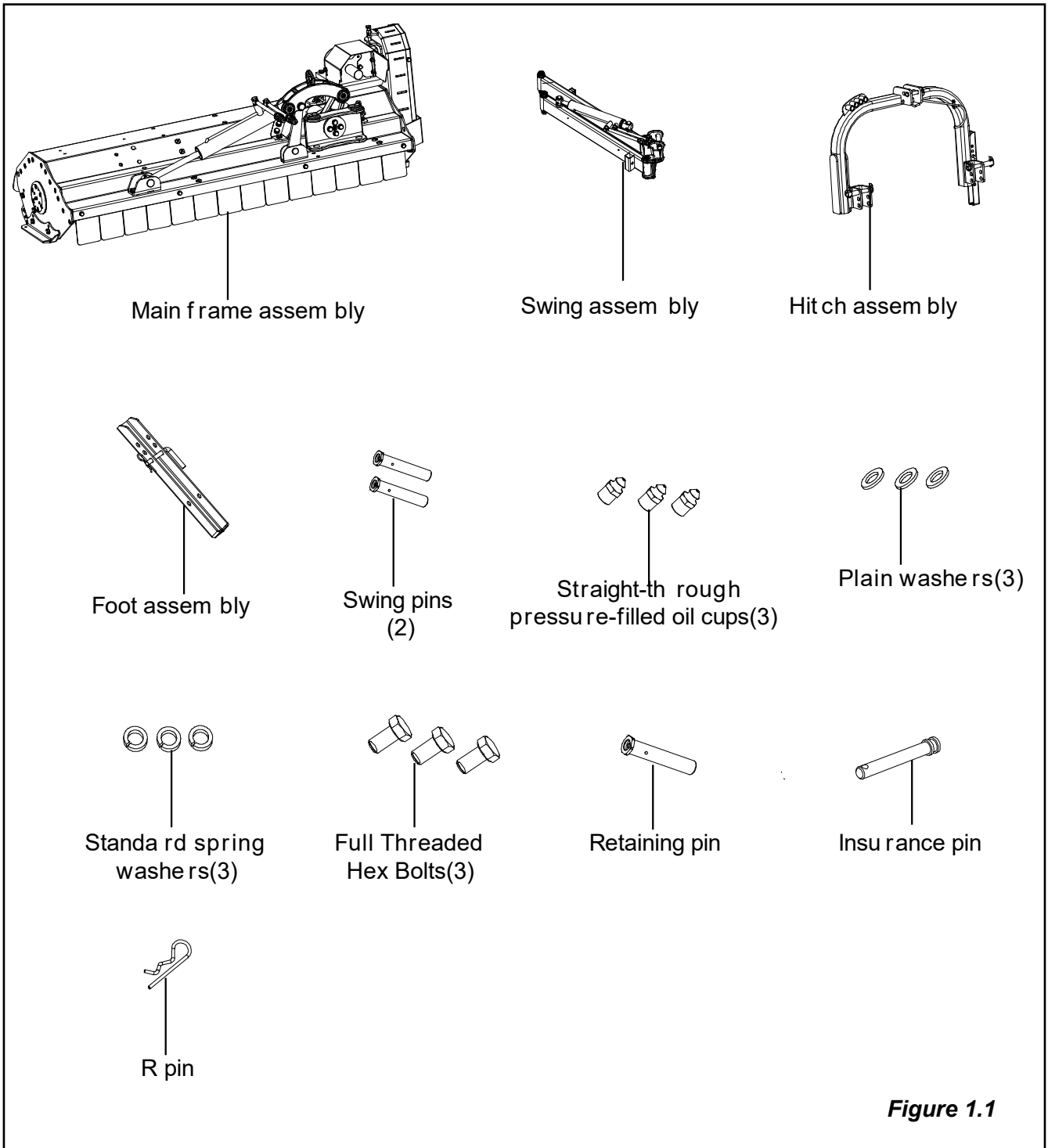

ASSEMBLY

Installation of hitch assembly and swing arm assembly

Refer to Figure2:

The hitch and swing arm assembly is disassembled for ease in shipping.

1. Assemble swing arm separately fixed on the hood panel assembly
2. Insert swing pins into the hole on the swing arms separately.
3. Installation of flat washers, spring washers and bolts to secure the swing pin
4. install straight-through pressure-filled oil cup on the swing pin
5. Apply correct torque for all fasteners

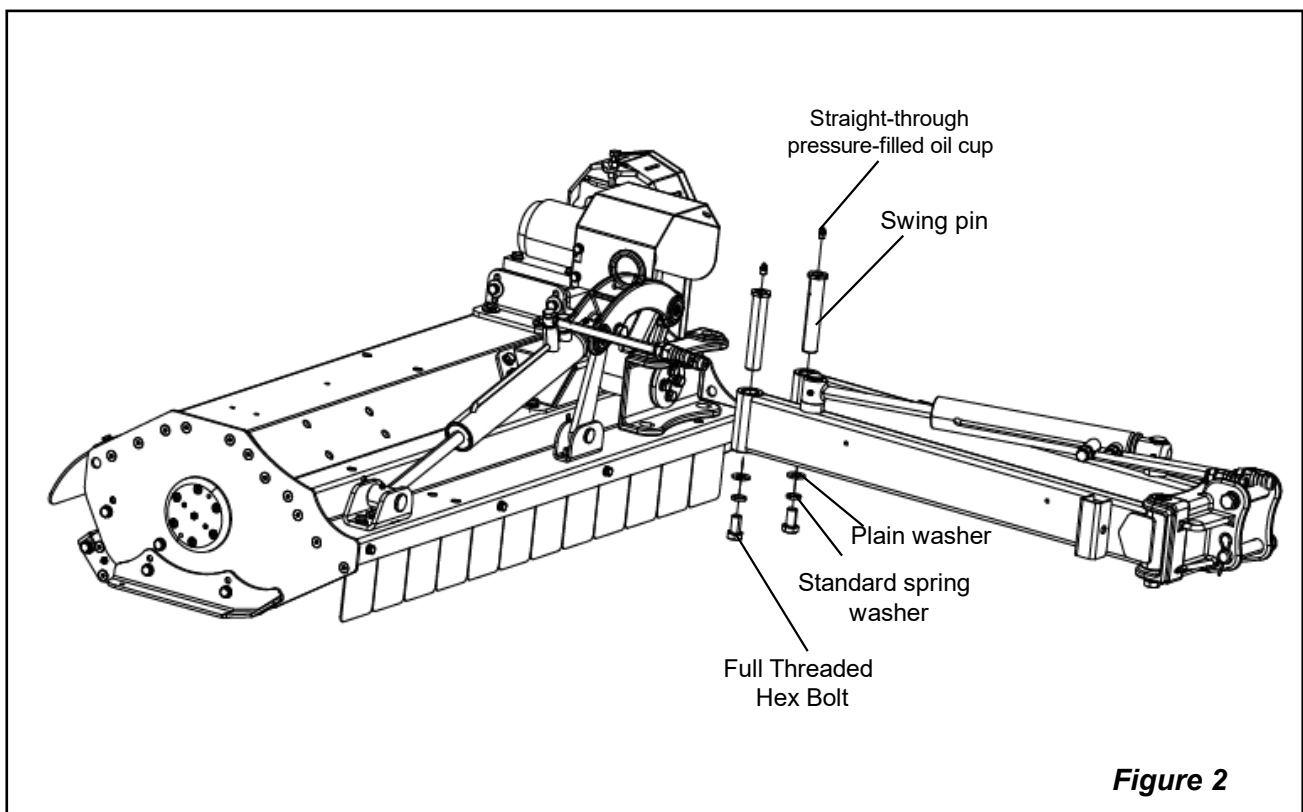

Refer to Figure2.1

1. Assemble hitch assembly separately fixed on the main frame
2. Insert R pins into the hole on the swing arms separately.
3. Installation of flat washers, spring washers and bolts to secure the R pin
4. install straight-through pressure-filled oil cup on the R pin
5. Insert the safety pins into the holes in the swing arm and secure them with R pins respectively
6. Apply correct torque for all fasteners

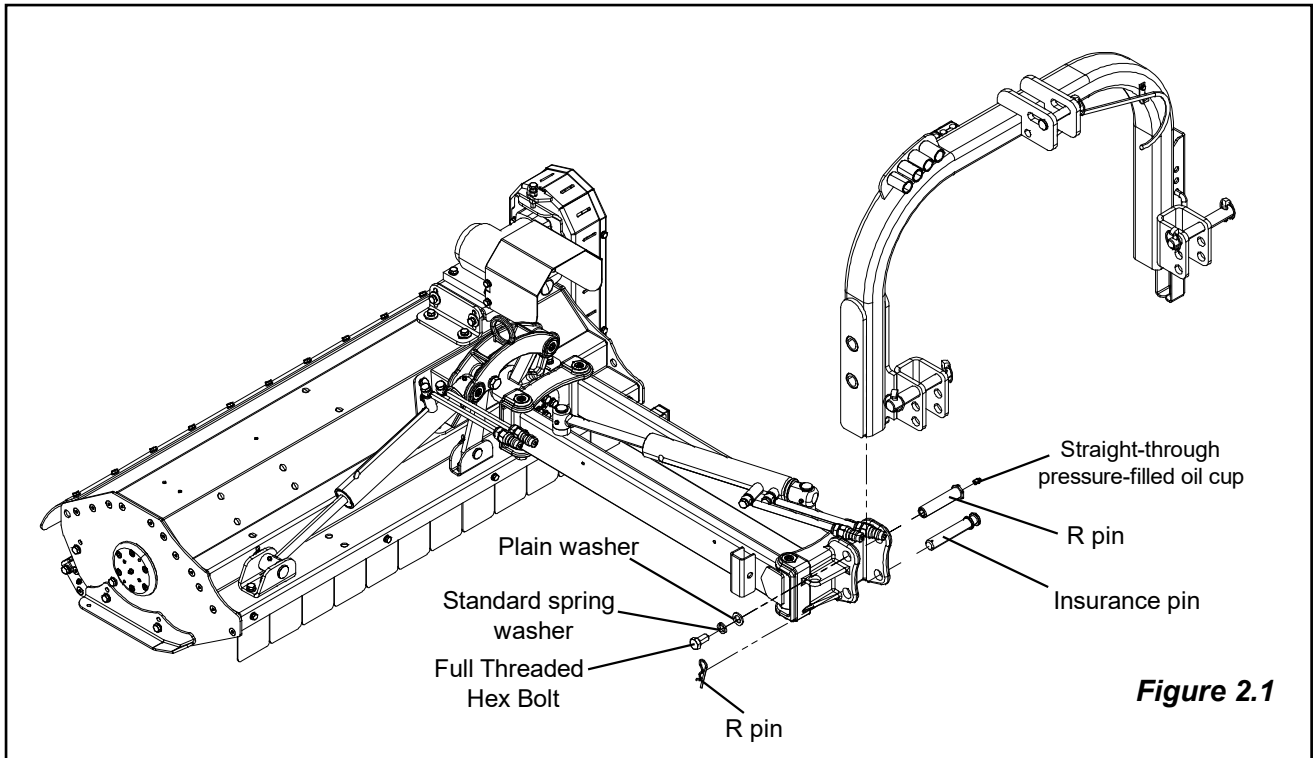

Installation of the foot assembly

1. Align the bottom most hole in the spacer plate on the swing assembly,
2. Fit the spacer assembly in and then secure it with a spacer pin through the hole and then snap an R pin over the spacer pin.

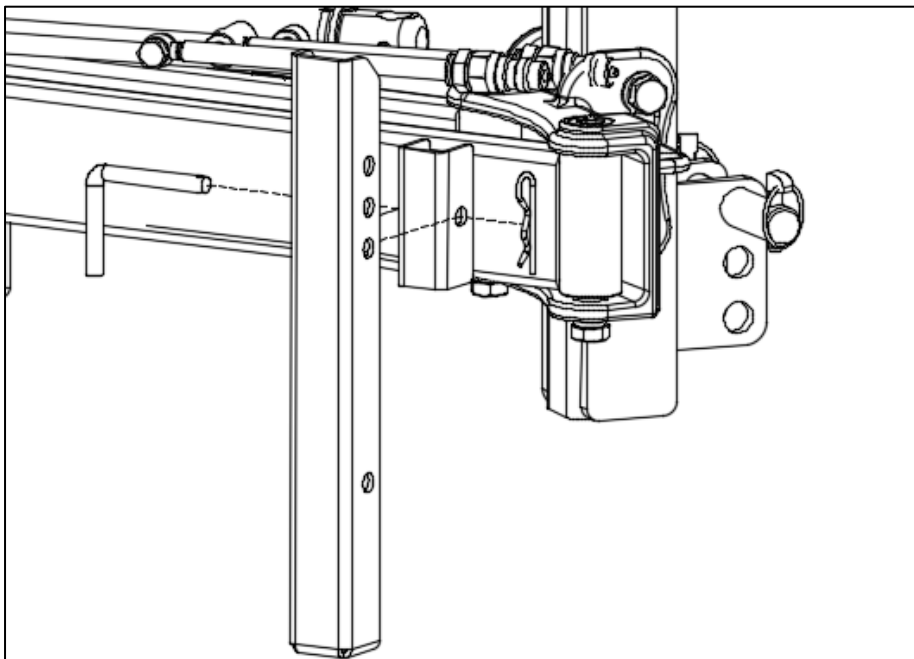

Tractor Hook-up

WARNING

- A crushing hazard exists while hooking-up and unhooking the implement. Keep people and animals away while approaching the implement or pulling away from the implement. Do not operate hydraulic controls while a person or an animal is nearby.
- Always follow “Tractor Shutdown Procedure” provided in tractor manual.
- Tractor horsepower and hitch category should be within the required range. The lower 3-Point arms must be stabilized to prevent side-to-side movement.

See *Figure 3*

1. Be certain tractor draw bar does not interfere. Move draw bar ahead or remove if required.
2. Remove all hitch pins and linchpins.
3. Attach tractor's top center link and lower arms with 3-point hitch correspondingly and secure with pins accordingly.
4. 3. Align ball swivels in the tractor's lower 3 - Point arms with pin holes in the lower hitch clevises of the Mowers . Insert hitch pins and secure with hair pin cotters.
5. Align the top center link with the center hitch Clevis of the Mowers. Insert hitch pin and secure with hair pin cotter.
6. With tractor's 3 - Point controls, lift Mowers up 1 to 2 inches and then raise jack stands fully up. Secure stands with jack pins and hair pin cotters.
7. Level Mowers by adjusting lower 3 - Point upper center link. Refer to “Leveling the Mowers.

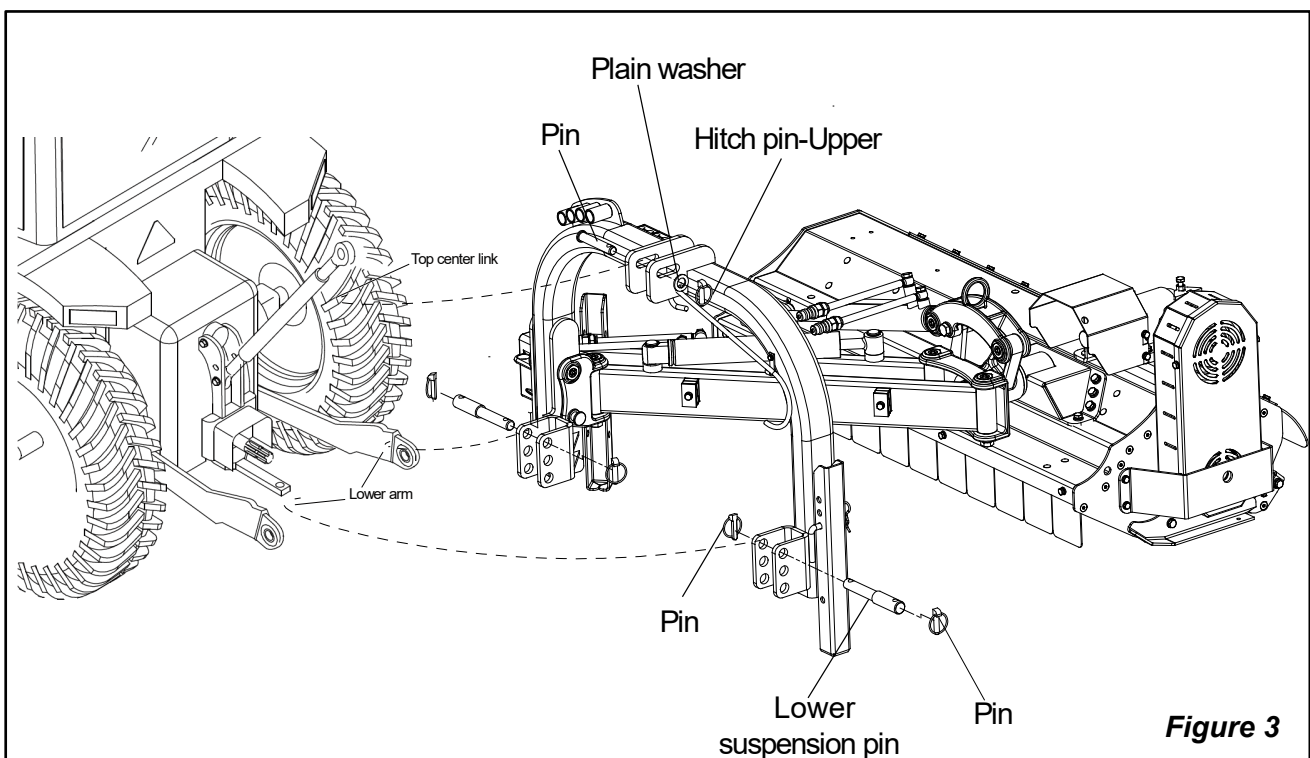

Driveline Installation

Note: There are 3 types of PTO shafts available.

DANGER

- Do not engage tractor PTO while hooking-up and unhooking the prop shaft or stand near a rotating prop shaft. A person's body and/or clothing may get entangled to cause severe injury.
- Do not use a power take-off adapter. The adapter will increase strain on the tractor's power take-off shaft causing possible damage to shaft and driveline. It will also defeat the purpose of the tractor's power take-off shield.
- Make certain driveline yokes are securely fastened at each end. A loose yoke can work free allowing the driveline to rotate uncontrollably.

See Figure 4

Type A shaft has interchangeable ends for installation;

Type B shaft shall have the end where safety pin locates connected with the implement;

Type C shaft shall have end where the clutch locates connected with the implement.

Type D shaft shall have end where the wide angle joint locates connected with the tractor.

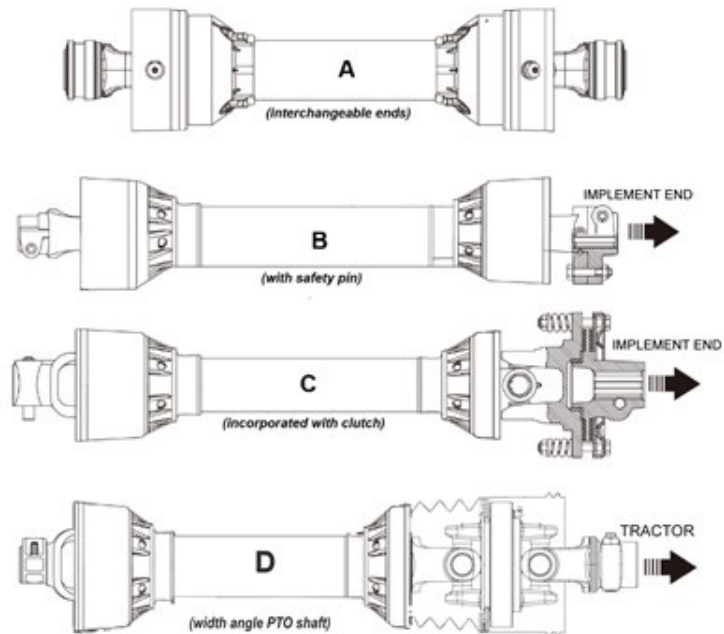

Figure 4

1. Park tractor on a level surface. Slowly engage tractor 3-Point lift lever to raise Mowers until gearbox shaft is in line (level) with tractor PTO shaft.
2. Support Mowers deck at this height with support jacks or blocks to keep Mowers from drifting down.
3. Place gear selector in park, set park brake, shut tractor off, and remove switch key.
4. Slide inner yoke (implement end) of driveline onto the gearbox. Secure driveline with yoke locking device.
5. Slide outer yoke of driveline over the tractor PTO shaft. Secure driveline with yoke locking device.
6. If the driveline is too long and does not fit between tractor and gearbox, skip to "**Customize driveline**" to shorten the driveline.
7. The driveline should now be moved back and forth to ensure secured connection at both ends. Reattach any end that is loose. Go to "**Driveline length check**" below to ensure proper accommodation.

8. Hook driveline safety chain on the tractor end of driveline to the tractor. Re-latch safety chain to the driveline shield.
9. Hook driveline safety chain on the Mowers end of driveline to the Mowers frame. Re-latch safety chain to the driveline shield.

Driveline length check

Before operating the Flail Mower, ensure that the size of driveshaft is adequate. The driveshaft supplied with the machine has a standard length, therefore it may need an adaptation of the length, depending of the tractor which the Flail Mower is attached with.

Maximum compressed position

The power take-off shaft and gearbox input shaft must be aligned and level with each other when checking driveline minimum length. A driveline that is too long can damage tractor and implement.

See Figure 5

Hold inner and outer drivelines parallel to each other as shown and measure distance **L1**:

1. If **L1** is less than 1" (2.5 cm), skip to "**Customize driveline**" to shorten the driveline.
2. If **L1** is greater than or equal to 1" (2.5 cm), skip to "**Maximum extended position**" below.

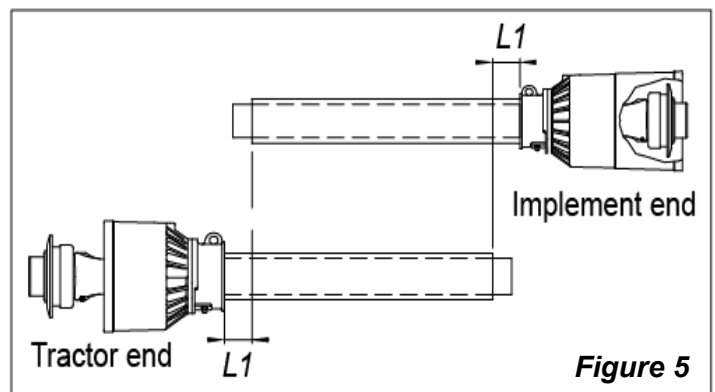

Figure 5

Maximum extended position

See Figure 6

The driveline maximum allowable length must, when fully extended, have a minimum overlap (**L2**) of profile tubes by not less than 1/3 the free length with both inner and outer profile tubes being of equal length.

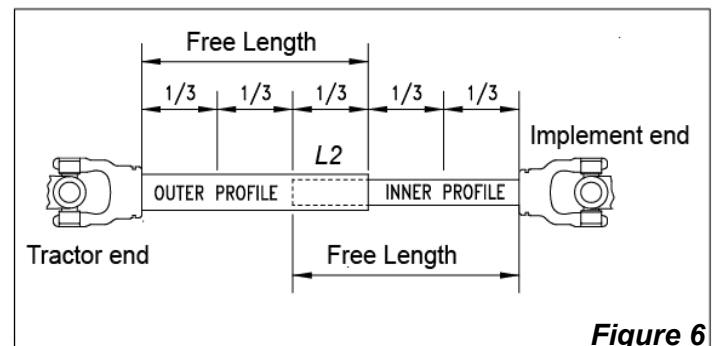

Figure 6

Customize driveline

See Figure 7

1. Un-hook driveline from tractor PTO shaft and pull outer and inner drivelines apart.
2. Re-attach outer driveline to tractor PTO shaft. Pull on inner and outer drivelines to be sure universal joints are properly secured.
3. Hold inner and outer drivelines parallel to each other:

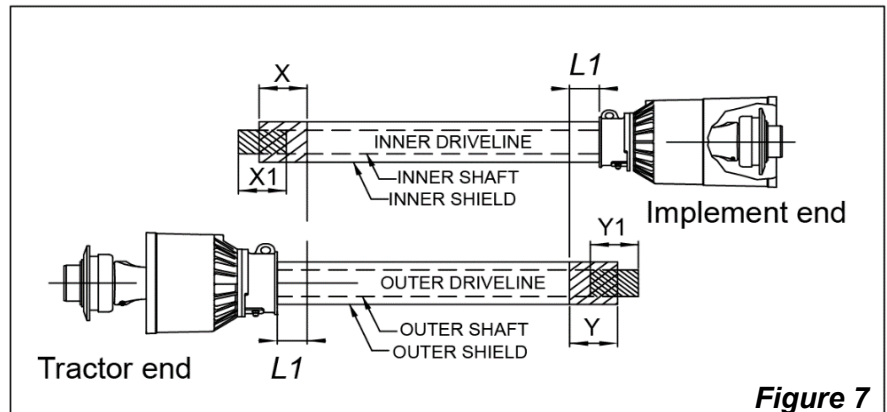

Figure 7

- a. Measure 1" (2.5 cm) ("**L1**" dimension) back from outer driveline universal joint shield and make a mark at this location on the inner driveline shield.
 - b. Measure 1"(2.5 cm) ("**L1**" dimension) back from the inner driveline universal joint shield and make a mark at this location on the outer driveline shield.
4. Remove driveline from tractor and gearbox shafts.
 5. Measure from end of inner shield to scribed mark ("X" dimension). Cut off inner shield at the mark. Cut same amount off the inner shaft ("X1" dimension).
 6. Measure from end of outer shield to scribed mark ("Y" dimension). Cut off outer shield at the mark. Cut same amount off the outer shaft ("Y1" dimension).
 7. Remove all burrs and cuttings.
 8. Apply multi-purpose grease to the inside of the outer shaft and reassemble the driveline

Driveline interference check

See Figure 8

lowly engage tractor 3-Point control lever to lower Mowers while checking for sufficient drawbar clearance. Move drawbar ahead, aside, or remove if required.

1. Raise and lower implement to find maximum extended driveline length. Check to make certain the driveline does not exceed the maximum allowable length and 25° up or down.
2. If needed, set tractor 3-Point lift height to keep driveline from exceeding the maximum allowable length and 25° up or d

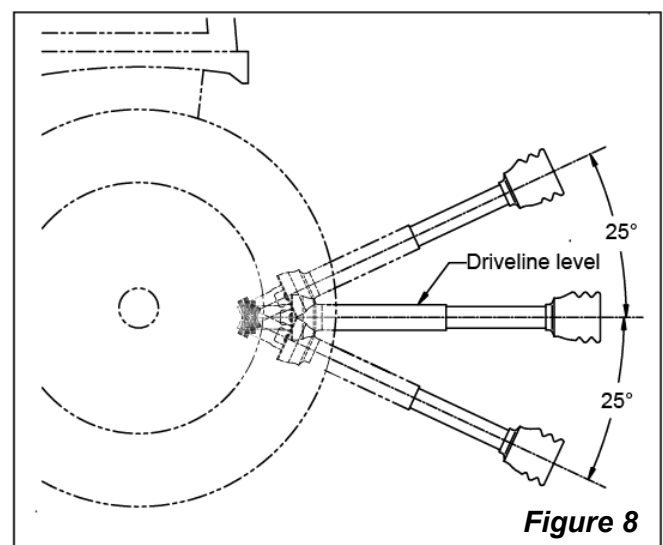

Figure 8

OPERATION

General Operating Instructions

! Now that you have familiarized yourself with the Operator's Manual, completed the Operators Checklist, properly attached your Mowers to your tractor, made the right offset or center adjustments, and preset your Crushing height, you're almost ready to begin using the mower.

It's now time to do a running operational safety check. If at any time during this safety check you detect a malfunction in either the Mowers or tractor shut the tractor off immediately, remove the key, and make necessary repairs or adjustments before continuing on.

Make sure the tractor's park brake is engaged, the tractor's PTO is disengaged, and the Mowers is resting on the ground. Start the tractor and then back the tractor throttle off till the engine is at low idle. With the tractor's rear hydraulic lift control lever, raise the Mowers to transport position making sure that the PTO shaft is not in a bind and does not come in contact with the Mowers frame. Lower the unit to Crushing position and, with the tractor still at low idle, engage the PTO. If everything is running smoothly at this point increase the engine rpm until the tractor's engine reaches full PTO operating speed which will be 540 rpm. Slowly raise the cutter to transport height to make sure the driveline does not bind or chatter. Then return the engine to low idle, disengage PTO, and position the adjustable stops on the tractor's hydraulic lift lever control console so the cutter can be consistently returned to the same Crushing and transport height.

You should now be ready to move to the Crushing site to begin working. You should have inspected and should only be Crushing in an area you are familiar with which is relatively free of debris and unseen objects. Never assume an area is clear. In the event you do strike an object, stop the tractor and Mowers immediately to inspect the rotor and make any necessary repairs before resuming operation. It pays to inspect a new area and to develop a plan before cutting.

Normal working speed will be between 2-5 mph and you will need to maintain tractor PTO speed to produce a clean cut so make a tractor gear and range selection that will maintain this combination. Generally the quality of cut of will be better at lower ground speeds and crushing denser ground cover or heavier brush may create the need to slow down. Always cut downward on slopes and avoid crossing the face of steep slopes. Avoid sharp drops and cross diagonally through dips to prevent hanging up the tractor and Mowers. Slow down in turns and avoid sharp turns if at all possible. Remember to look back often.

CAUTION

Engage parking brake, shut off tractor, remove key, and disengage PTO before making any adjustments!

Now you're prepared and well briefed so let's begin Cutting. Reduce the tractor's engine rpm, make sure the Mowers is on the ground and in Crushing position, engage the PTO, raise the engine rpm to

the appropriate PTO speed, and begin working. Operators must plan a head and choose a Crushing route that allows safe turns. Try increasing or decreasing ground speed to determine the effect on quality of cut.

! CAUTION

Engage parking brake, shut off tractor, remove key, and disengage PTO before making any adjustments!

! CAUTION

Ensure Mowers with special supports if it is necessary to lift Mowers off the ground to make adjustments! If not supported, the Mowers could fall causing serious injury to those present.

Checklist before Operation

 **CAUTION**

Hazard control and accident prevention are dependent upon the awareness, concern, prudence, and proper training involved in the operation, transport, storage, and maintenance of the mower. Therefore, it is absolutely essential that no one operates the machine without first having read, fully understood, and become totally familiar with the Operator's Manual. Make sure all operators have completed the Checklist below.

Before operating the machine, the following steps should be inspected carefully:

1. Before starting up the machine, check and lubricate all grease points, on the machine and drive shaft. Check the oil level in the gearbox. Add as required.
2. Use only an agricultural tractor with horsepower within limits of the implement.
3. Check that the machine is properly attached to the tractor. Be sure retainers are used on the mounting pins.
4. Be sure extra weights are mounted on the front of the tractor, if required.
5. Check that the tractor PTO shaft turns freely and that the machine driving shaft can telescope easily.
6. Check the blades. Be sure they are not damaged or broken and swing freely in their mount. Repair or replace as required.
7. Check and tighten the blade bolts.
8. Check for entangled material in all rotating parts. Remove this material.
9. Install and secure all guards, hook and covers before starting.
10. Before installing the PTO ensure the engine is stopped and the PTO shaft is in safe working order.
11. All other people shall leave the area before connecting the driving power from the tractor.

12. Before cleaning, repairing and lubricating the machine, stop the motor and take the key away with you.
13. When the PTO shaft is not connected with the tractor, support it through the frame to protect it from lying in the dirt.
14. Don't approach the machine when it is operating.

Adjusting Roller/Skid Height

CAUTION

The roller must be adjusted into the same position on both sides.
The blades must never be less than 1" (2.5 cm) from the ground.
The skid shoes must be at least 3/4" (2 cm) off the ground when in operation.

See Figure 9

There are three optional locations for roller height adjustment indicated
Park tractor and implement on a flat, level surface.

1. Lower tractor lift arms to bring the roller in contact with the ground and make sure the flail head is parallel with the ground.
2. Shut tractor down according to procedures mentioned in tractor manual.
3. Raise and secure the implement with solid and firm support blocks.
4. Untighten and remove the **height adjustment bolt** as well as associated washers and nuts;
5. Adjust roller to the desired height by choosing one of the three locations;
6. Secure the bolts with removed washers and nuts;
7. Accordingly adjust the **skid shoe** by untightening the bolts as well as associated washers and nuts.
8. Inspect blades to make sure they do not touch the ground. Blades that come in contact with the ground will wear quickly. If necessary, readjust cutting height to keep blades from touching the ground.

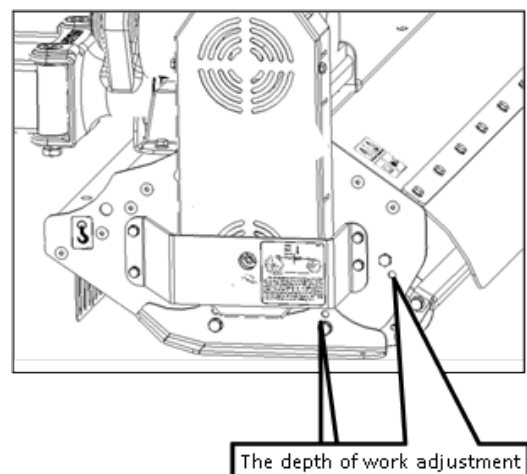

Adjusting the Belt

CAUTION

- Always shut tractor down before servicing, adjusting, cleaning, or maintaining this implement
- Always wear appropriate PPE, such as gloves, safety glasses, and hearing protection to protect yourself from any potential hazards.
- Block the mower securely in place to prevent any movement during the adjustment process.
- Excessive tension on the belt may lead to premature failure of belt and drive components. Excessive tension on the belt may also lead to a safety hazard to the operator or bystanders.
- The Belt tension should be checked after the first 20 hours of use and every 40 hours thereafter.
- Check belt tension by applying approximately 22 pounds of pressure half way between the pulleys.
The belt should deflect approximately 3/8".

See Figure 10

The Belt tension should be checked after the first 20 hours of use and every 40 hours thereafter.

1. Check belt tension by applying approximately 22 pounds of pressure half way between the pulleys.
The belt should deflect approximately 3/8".
2. Belt tension can be adjusted at the belt tension bolt.
Turn belt tension bolt until desired belt tension is achieved.
3. Loosen gearbox mounting bolts and move gearbox until Mowers driveline is running straight with the Flail Mower

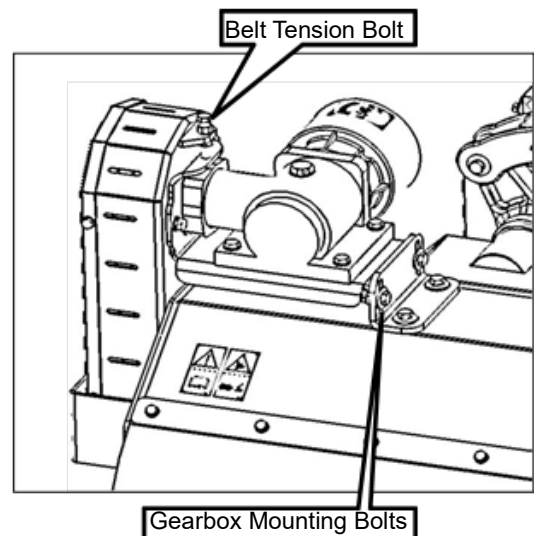

Starting the Machine

WARNING

- The flail mower must only be in the working position while moving forward and must be raised when backing-up. Operating the flail mower in the working position while backing-up can seriously damage the flail mower.
- Never use the flail mower with the tractor straddling a ditch.
- Only operate the flail mower inclined when in the lateral extended configuration. When the mower is in the center configuration, only operate it horizontally.
- Make sure that there are no persons or animals in the vicinity.

DANGER

To avoid tractor overturning hazard

- Never allow the tractor to take the weight of the flail mower when working on inclined surfaces (ditches, slopes etc.), as the combined weight of the tractor and flail mower may cause the tractor to overturn.
- Lightweight tractors with rear attached implements may need weights added to the front to maintain steering control.
- Consult your tractor Operator's Manual to determine proper weight requirements and maximum weight limitations.
- Survey any incline surface the tractor will be traveling on for holes and low depressions in the ground that the tractor wheel can drop into suddenly causing the tractor to overturn unexpectedly. Avoid such drop-offs.

Before starting the machine, check and adjust the following items:

1. Drive belt tension.
2. Gearbox oil level.
3. Grease nipples on bearings and PTO shaft.
4. All bolts, nuts and screws.

SERVICE AND MAINTENANCE

General Service

The period recommended is based on normal operating conditions. Severe or unusual conditions may require more frequent service.

Each 4 hours of work:

Check and tighten nuts and bolts.

Grease with lithium based grease when it is indicated by the symbol GREASE.

After 50 hours of work:

Check and fill the gearbox to the required level, using oil type SAE EP 90W.

Gearbox Maintenance

The oil should be drained out and replaced after the first 50 hours of operation. Then the oil should be changed every 250 hours.

Drain oil from the gearbox thoroughly. Check and clean it. Fill with new gear oil up to the dedicated oil level.

The draining procedure is as follows: remove the draining bolt under the gear box, so that the oil drains off. After the oil is drained out, put the plug back and fill with gear oil up to the dedicated oil level.

PTO Shaft Maintenance





It is recommended to lubricate the PTO shaft with multi-purpose grease after every 8 to 10 hours of use during heavy use. The PTO shaft is designed to telescope to allow for dimensional changes as the machine goes through its operating range. A tubular guard encloses the driving components and is designed to turn relative to the driving components. The shaft should telescope easily and the guard turn freely on the shaft at all times. Annual disassembly, cleaning and lubrication is recommended to insure that all components function as intended. To maintain the shaft, follow this procedure:

1. Remove the shaft from the machine.
2. Pull shaft apart.
3. Use a screwdriver to pry the tabs out of the sleeves on each end.
4. Pull the shaft out of the plastic tubular guard.
5. Use a solvent to clean the male and female portions of the telescoping ends.
6. Apply a light coat of grease to each end.
7. Clean the grooves on each end where the tabs are located. Clean each tab also.
8. Apply a light coat of grease to each groove.





9. Insert the shaft into its respective guard and align the slots with the groove.
10. Insert the tabs through the slots and seat in the groove.
11. Check that each guard turns freely on the shaft.
12. Assemble the shaft.
13. Check that the shaft telescopes easily.
14. Replace any components that are damaged or worn.
15. Install the shaft on the machine.



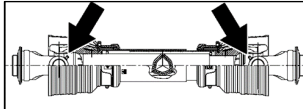
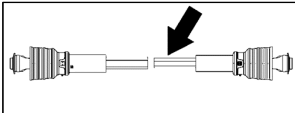
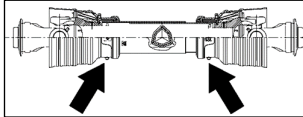

Lubrication Parts

Lubrication legend list:

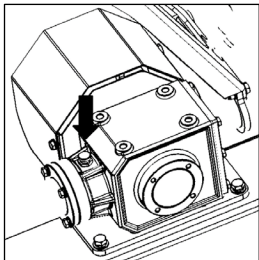
Name	Multi-purpose spray lube	Multi-purpose grease lube	Multi-purpose oil lube	Intervals in hours at which lubrication is required
Image				

Lubrication parts list:

Interval	Type	Name	Parts Image	Remark
	 Multi-purpose Grease	Driveline Shaft U-Joints		Quantity - 4 to 8 Pumps
		Driveline Profiles		Quantity - Clean & coat inner profile tube of driveline with a light film of grease and then reassemble.
		Inner Tube Bearings		Quantity - As Required
	 SAE EP 90W Gear Lube	Gearbox		Add visual to the center of the gear oil Reinstall plugs and tighten. Do not overfill! Should your gearbox require service, take it to your Manufacturer dealer.

Interval	Type	Name	Parts Image	Remark
	 Multi-purpose Grease	Other parts		If the GREASE labels () are posted on the machine, you need to lubricate it regularly. Recommend lubrication interval is 25hours.

Tightening Torque

Please follow the table below to identify the torque value as required.

Torque Values Chart for Common Bolt Sizes													
Bolt Size (inches)	Bolt Head Identification						Bolt Size (Metric)	Bolt Head Identification					
	Grade 2		Grade 5		Grade 8			Class 5.8		Class 8.8		Class 10.9	
in-tpi ¹	N · m ²	ft-lb ³	N · m	ft-lb	N · m	ft-lb	mm x pitch ⁴	N · m	ft-lb	N · m	ft-lb	N · m	ft-lb
1/4" - 20	7.4	5.6	11	8	16	12	M 5 X 0.8	4	3	6	5	9	7
1/4" - 28	8.5	6	13	10	18	14	M 6 X 1	7	5	11	8	15	11
5/16" - 18	15	11	24	17	33	25	M 8 X 1.25	17	12	26	19	36	27
5/16" - 24	17	13	26	19	37	27	M 8 X 1	18	13	28	21	39	29
3/8" - 16	27	20	42	31	59	44	M10 X 1.5	33	24	52	39	72	53
3/8" - 24	31	22	47	35	67	49	M10 X 0.75	39	29	61	45	85	62
7/16" - 14	43	32	67	49	95	70	M12 X 1.75	58	42	91	67	125	93
7/16" - 20	49	36	75	55	105	78	M12 X 1.5	60	44	95	70	130	97
1/2" - 13	66	49	105	76	145	105	M12 X 1	90	66	105	77	145	105
1/2" - 20	75	55	115	85	165	120	M14 X 2	92	68	145	105	200	150
9/16" - 12	95	70	150	110	210	155	M14 X 1.5	99	73	155	115	215	160
9/16" - 18	105	79	165	120	235	170	M16 X 2	145	105	225	165	315	230
5/8" - 11	130	97	205	150	285	210	M16 X 1.5	155	115	240	180	335	245
5/8" - 18	150	110	230	170	325	240	M18 X 2.5	195	145	310	230	405	300
3/4" - 10	235	170	360	265	510	375	M18 X 1.5	220	165	350	260	485	355
3/4" - 16	260	190	405	295	570	420	M20 X 2.5	280	205	440	325	610	450
7/8" - 9	225	165	585	430	820	605	M20 X 1.5	310	230	650	480	900	665
7/8" - 14	250	185	640	475	905	670	M24 X 3	480	355	760	560	1050	780
1" - 8	340	250	875	645	1230	910	M24 X 2	525	390	830	610	1150	845
1" - 12	370	275	955	705	1350	995	M30 X 3.5	960	705	1510	1120	2100	1550
1-1/8" - 7	480	355	1080	795	1750	1290	M30 X 2	1060	785	1680	1240	2320	1710
1-1/8" - 12	540	395	1210	890	1960	1440	M36 X 3.5	1730	1270	2650	1950	3660	2700
1-1/4" - 7	680	500	1520	1120	2460	1820	M36 X 2	1880	1380	2960	2190	4100	3220
1-1/4" - 12	750	555	1680	1240	2730	2010							
1-3/8" - 6	890	655	1990	1470	3230	2380							
1-3/8" - 12	1010	745	2270	1670	3680	2710							
1-1/2" - 6	1180	870	2640	1950	4290	3160							
1-1/2" - 12	1330	980	2970	2190	4820	3560							

¹ in-tpi = nominal thread diameter in inches-threads per inch
² N · m = newton-meters
³ ft-lb = foot pounds
⁴ mm x pitch = nominal thread diameter in millimeters x thread pitch

Torque tolerance + 0%, -15% of torquing values. Unless otherwise specified use torque values listed above.
 All locknuts or lubricated fasteners: Use 75% of torque value. (i.e. 1/2"-13 GR5 = 76 ft-lb; 75% of 76 or .75 x 76 = 57 ft-lb)

- This chart is an approximate estimate of torque values.
- Always tighten hardware to these values unless a different torque value or tightening procedure is listed for a specific application.
- Fasteners must always be replaced with the same grades as specified in the manual.
- Always use the proper tool for tightening hardware; SAE for SAE hardware and Metric for Metric hardware.
- Make sure that fastener threads are clean and that you properly start thread engagement.

Replacing the Blade

Frequently check rotor blades to make sure they are in good working condition and properly secured to the rotor.

Replace worn or damaged parts with new blades.

IMPORTANT:

- Make sure that the replacement of blade with other same weight. This will be a balance of rotor spinning.
- Recommend blade is the original factory accessories.

Frequently check rotor blades and static blades to make sure they are in good working condition and properly secured. Replace worn or damaged parts with new blades. Make sure that the replacement of blade in the same weight to guarantee a balance of rotor spinning. The replaced blade must be the original factory accessories.

Hammer blades replacement steps

1. Untighten the nut;
2. Remove the bolt;
3. Replace the worn-out blade with a new one.
4. Put back the bolt and tighten the nut with required torque.

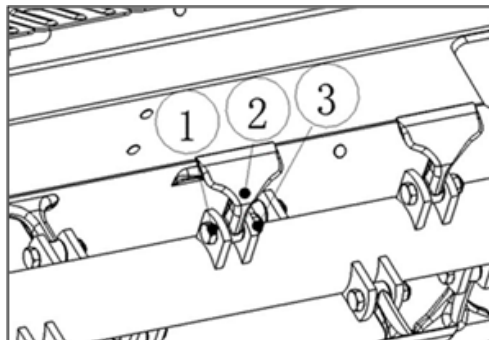
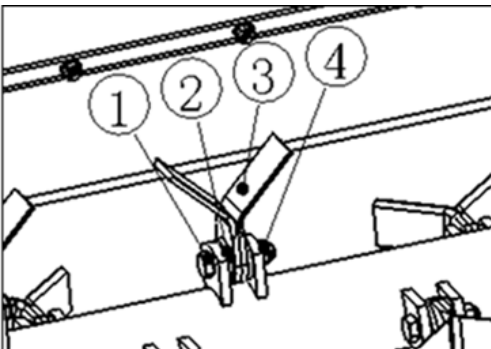

STORAGE AND TRANSPORT

Storage

Before storage the implement, you should following the steps below:

1. Remove any dirt and grease that may have accumulated on the mower and moving parts.
Scrape off compacted dirt from under the hood. Clean the machine inside and out so as to avoid corrosion.
2. Check rotor, blades, blade mounts, and blade bolts for wear and replace if necessary.
3. Don't spray water on the rolling bearing if you clean the machine with high pressure sprayer.
4. Check and clean the universal joint, driving belt press roller, or replace them if they are not in good condition. Lubricate wherever needed.
5. Recoat the parts rubbed and damaged for anti-corrosion.
6. Store the machine in a dry, level area.

Transport

WARNING

- Always disengage power take-off before raising mower to transport position.
- When traveling on roadways, travel in such a way that other vehicles may pass you safely.
Always use LED lights, clean reflectors, and a slow moving vehicle sign that is visible from the back to warn operators in other vehicles of your presence.
- Always comply with all federal, state, and local laws.

Before transport the implement, you should following the steps below:

1. When raising mower to transport position, be sure driveline does not contact tractor or mower. If needed, adjust and set tractor 3-point lift height to limit mower movement and to protect driveline.
2. Be sure to reduce tractor ground speed when turning, leaving enough clearance so that the mower does not contact obstacles such as buildings, trees, fences, etc.
3. Select a safe ground travel speed when transporting from one area to another. When traveling on roadways, transport in such a way that faster moving vehicles may pass safely.
4. When traveling over rough or hilly terrain, shift tractor to a lower gear.

TROUBLESHOOTING

Listed general troubleshooting is the common malfunction that may or may not be application to the described in this manual. If you have any problem not covered in the list, please contact us for technical supporting.

General troubleshooting list:

Malfunction	Possible Cause	Solution
Belt slippage	Blades touch the ground	Adjust the skids or roller correctly
	Belts worn	Replace a new belts
	Belt is not tensioned correctly	Correct belt tension, see Adjusting the Belt
	Belt tensioner is damaged	Replace a new one
	Clogging	Clean the machine to remove accumulated debris.
Belt failure	Incorrect belt alignment	Align the belts.
	Belt tensioner spring has lost its memory or is broken	Replace belt tensioner spring and belts.
Significant machine vibration	Worn blades	Replace the blades
	Missing blades	
	Broken blades	
	Worn rotor support bearings	Replace the bearings
	Rotor fouled with debris	Clean rotor
	Loose parts	Tighten bolts and fasteners
	Incorrect power take-off speed	Select correct tractor power take-off speed
Excessively rapid blade wear	Blades touching the ground	Check and, if necessary, adjust cut height.
Blades tear rather than cut, shredded material not distributed evenly	Ground speed too high	Reduce the speed
	Cut height too low	Adjust cut height
	Excessive build-up of material under the flail head	Clean the flail head

Malfunction	Possible Cause	Solution
	Clogging	Clean the machine to remove accumulated debris
Roller does not turn easily	Insufficient greasing	Grease as indicated
	Roller casing bearings worn	Replace the bearings
	Roller or mounts damaged or bent	Replace damaged parts
Excessive driveline noise	Insufficient greasing	Apply grease as indicated in the Maintenance section
	Worn trunnion bearing	Replace bearings
	Exceeds 25 degrees	Do not exceed 25 degrees
Driveline wear	Insufficient greasing	Apply grease as indicated in the Maintenance section
	Operating angle incorrect	Reduce the operating angle
	Overloading	Avoid overloading and do not start the machine when loaded
Breakage or deformation of the driveline	Overloading	Avoid overloading and do not start the machine when loaded
	Operating angle incorrect	Reduce the operating angle
Unit overheating	Not enough oil in the unit	Check seals and gaskets and replace any that are damaged
		Top off the oil
	Incorrect oil type	Replace with the prescribed type of oil
	Excessive oil	Restore correct oil level
	Overloading	Observe the prescribed speed and power conditions
Lateral adjustment and/or inclination angle adjustment functions not working correctly	Hoses connected incorrectly to tractor remotes	Connect correctly
	Remotes or hydraulic pump on tractor faulty	Check and repair if necessary
	Oil leakage	Check connections and tighten correctly if necessary
		Check hydraulic hoses and replace if necessary

EXPLODED VIEWS & PARTS LIST

Shredder

ME-VS40

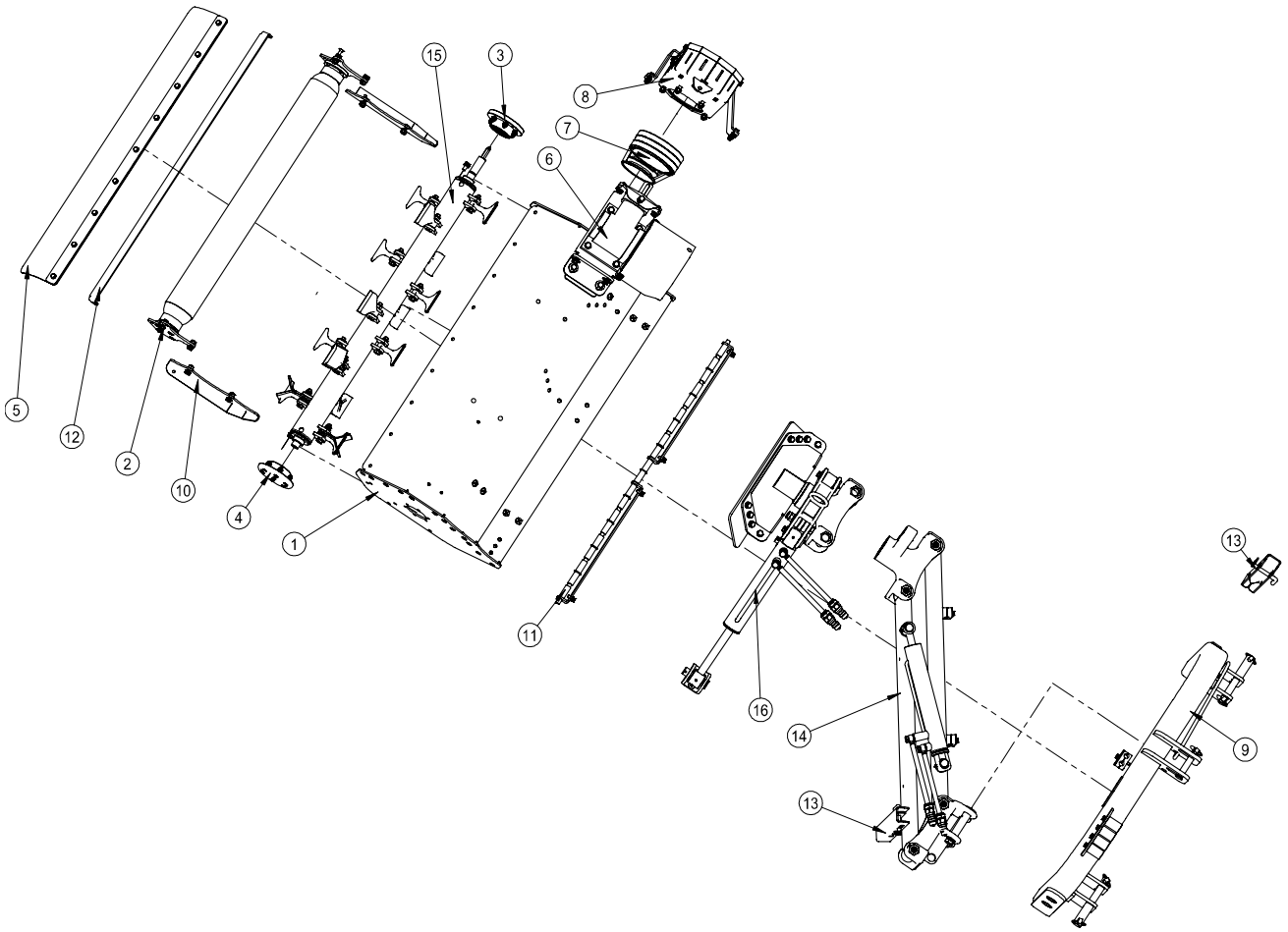

POS.	COD.	Specification	Description	Qty
1	2060108234	G02007A01000-000	Panel hood assembly	1
2	2060105039	G01009A03000-000	Roller assembly	1
3	2060105045	G01009A04000-000	Bearing seat assembly	1
4	2060105046	G01009A05000-000	Bearing seat assembly	1
5	2060105047	G01009A06000-000	Covering plate assembly	1
6	2060106767	G02001D08000-000	Gearbox drive shaft assembly	1
7	2060105179	G01009B09000-000	Side drive assembly	1
8	2060105052	G01009A11000-000	Side cover assembly	1
9	2060105140	G02001A12000-000	Hitch assembly	1

10	2060105056	G01009A14000-000	Skid plate assembly	1
11	2060108272	G02007A15000-000	Protective assembly	1
12	2060105057	G01009A17000-000	Scraper assembly	1
13	2060105138	G02001A16000-000	Supporting Assembly	2
14	2060105135	G02001A18000-000	Assembly	1
15	2090000266	G01009A02000-000	Axle assembly	1
16	2060108222	G02007A19000-000	Reverse assembly	1

ME-VS48-64

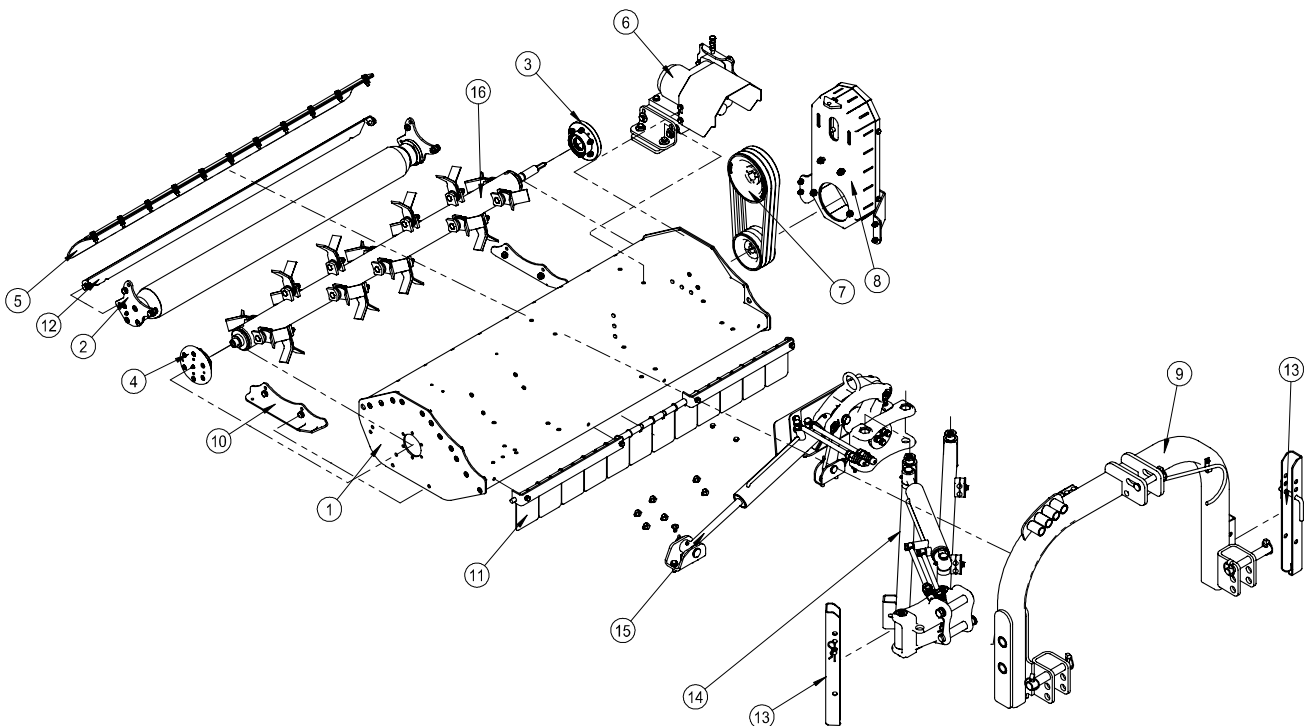

POS.	COD.	Specification	Description	VS48/ Qty	VS58/ Qty	VS64 /Qty
1	2060105036	G01010A01000-000	Panel hood assembly	1	-	-
1	2060105037	G01011A01000-000	Panel hood assembly	-	1	-
1	2060105038	G01012A01000-000	Panel hood assembly	-	-	1
2	2060105040	G01010A03000-000	Roller assembly	1	-	-
2	2060105041	G01011A03000-000	Roller assembly	-	1	-

2	2060105042	G01012A03000-000	Roller assembly	-	-	1
3	2060105045	G01009A04000-000	Bearing seat assembly	1	1	1
4	2060105046	G01009A05000-000	Bearing seat assembly	1	1	1
5	2060105048	G01010A06000-000	Covering plate assembly	1	-	-
5	2060105049	G01011A06000-000	Covering plate assembly	-	1	-
5	2060105050	G01012A06000-000	Covering plate assembly	-	-	1
6	2060106767	G02001D08000-000	Gearbox drive shaft assembly	1	1	1
7	2060105179	G01009B09000-000	Side drive assembly	1	1	1
8	2060105052	G01009A11000-000	Side cover assembly	1	1	1
9	2060105140	G02001A12000-000	Hitch assembly	1	1	1
10	2060105056	G01009A14000-000	Skid plate assembly	-	1	-
10	2060105056	G01009A14000-000	Skid plate assembly	1	-	1
11	2060105065	G01010A15000-000	Protective assembly	1	-	-
11	2060105066	G01011A15000-000	Protective assembly	-	1	-
11	2060105067	G01012A15000-000	Protective assembly	-	-	1
12	2060105058	G01010A17000-000	Scraper assembly	1	-	-
12	2060105059	G01011A17000-000	Scraper assembly	-	1	-
12	2060105060	G01012A17000-000	Scraper assembly	-	-	1
13	2060105138	G02001A16000-000	Supporting Assembly	2	2	2
14	2060105135	G02001A18000-000	Assembly	1	1	1
15	2060105136	G02001A19000-000	Reverse assembly	1	1	1
16	2090000270	G01010B02000-000	Axle assembly	1	-	-
16	2090000273	G01011B02000-000	Axle assembly	-	1	-
16	2090000275	G01012A02000-000	Axle assembly	-	-	1

HOOD ASSEMBLY

ME-VS40

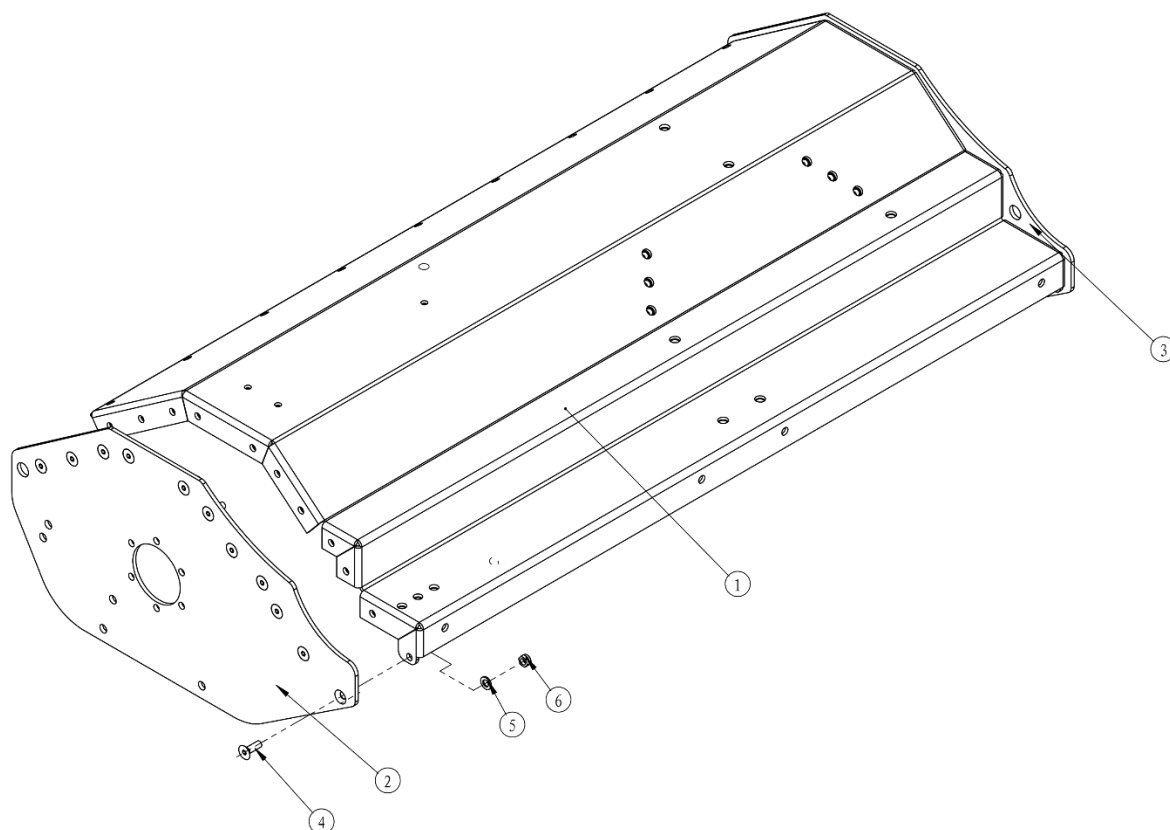

POS.	COD.	Specification	Description	Qty
1	2020008320	G02007A01100-000	Panel hood weldment	1
2	2000000250	G01009A01000-002	Left side panel of hood	1
3	2000000251	G01009A01000-003	Right side panel of hood	1
4	3060200019	GB/T70.3-M8×25-8.8-EP•Zn	HSCS-Countersunk	20
5	3080100004	GB/T95-8-EP•Zn	Plain washer	20
6	3050500003	GB/T889.1-M8-8-EP•Zn	Locknut	20

ME-VS48-64

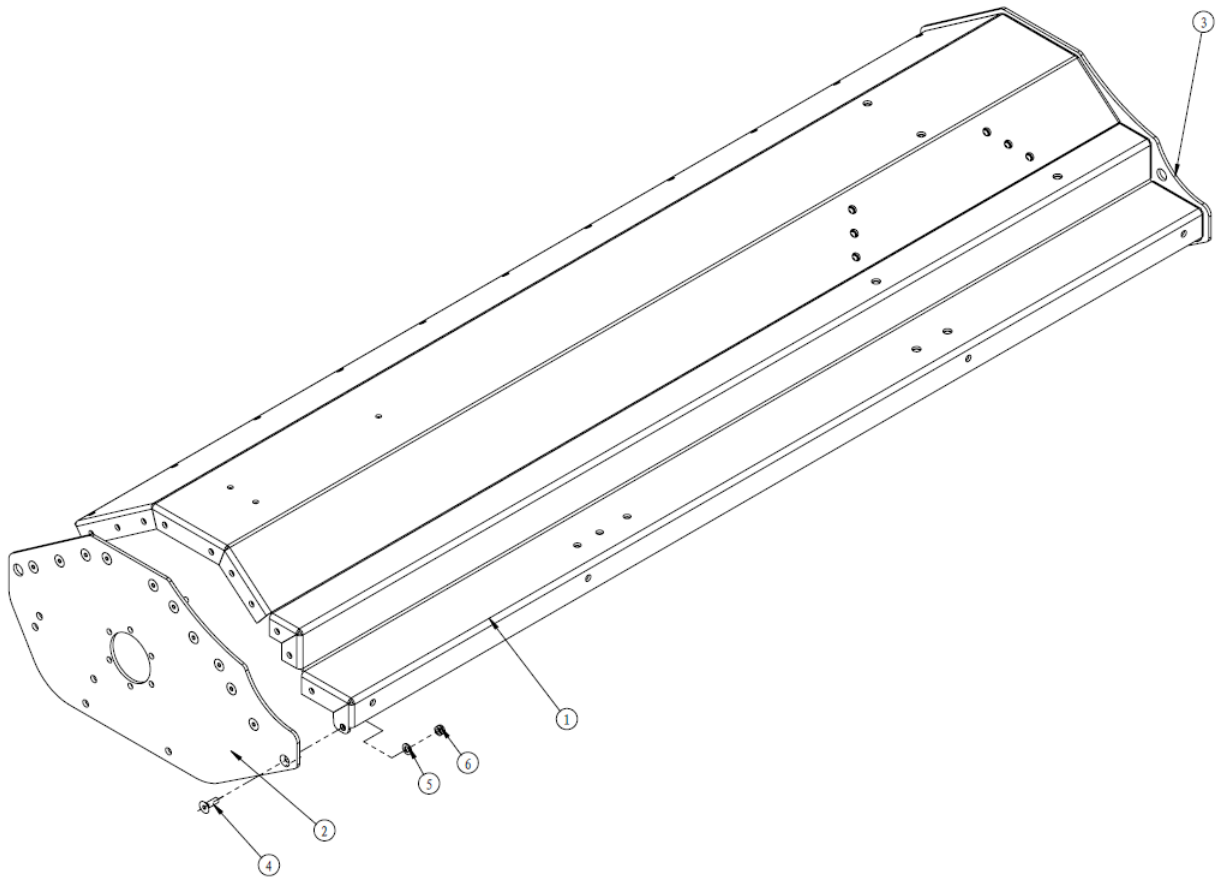

POS.	COD.	Specification	Description	VS48/Qty	VS58/Qty	VS64/Qty
1	2020008825	G01010B01100-000	Panel hood weldment	1	-	-
1	2020008826	G01011B01100-000	Panel hood weldment	-	1	-
1	2020008827	G01012B01100-000	Panel hood weldment	-	-	1
2	2000000250	G01009A01000-002	Left side panel of hood	1	1	1
3	2000000251	G01009A01000-003	Right side panel of hood	1	1	1
4	3060200019	GB/T70.3-M8×25-8.8-EP•Zn	HSCS-Countersunk	22	22	22
5	3080100004	GB/T95-8-EP•Zn	Plain washer	22	22	22
6	3050500003	GB/T889.1-M8-8-EP•Zn	Locknut	22	22	22

AXLE ASSEMBLY

Ordinary axle+hammer blade

Ordinary axle+Y blade

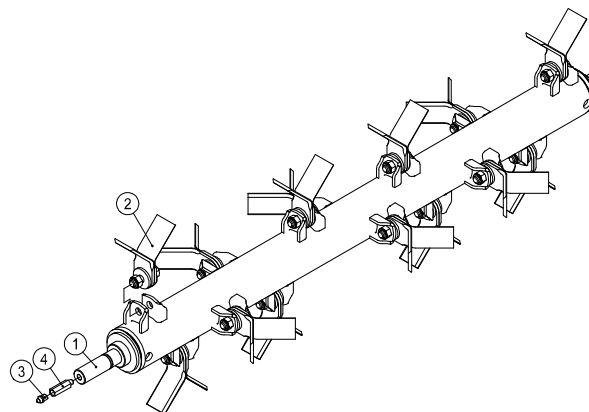
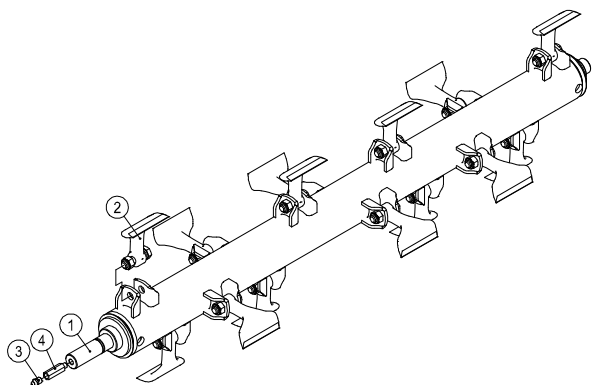

Ordinary axle+hammer blade

POS.	COD.	Specification	Description	VS40/Qty	VS48/Qty	VS58/Qty	VS64/Qty
1	2020000488	G01009A02100-000	Axle weldment	1	-	-	-
1	2020000489	G01010A02100-000	Axle weldment	-	1	-	-
1	2020000490	G01011A02100-000	Axle weldment	-	-	1	-
1	2020000491	G01012A02100-000	Axle weldment	-	-	-	1
2	2060204854	G01009A02200-000	Blade assembly	14	18	20	24
3	3170400005	DIN71412-A G1/8 304	Grease nipple	1	1	1	1
4	3181100610	MT85007	Pressure lubricator connector	1	1	1	1

Ordinary axle+Y blade

POS.	COD.	Specification	Description	VS40/ Qty	VS48/ Qty	VS58/ Qty	VS64/ Qty
1	2020000488	G01009A02100-000	Axle weldment	1	-	-	-
1	2020000489	G01010A02100-000	Axle weldment	-	1	-	-
1	2020000490	G01011A02100-000	Axle weldment	-	-	1	-
1	2020000491	G01012A02100-000	Axle weldment	-	-	-	1
2	2060205514	G01009C02200-000	Blade assembly	14	18	20	24
3	3170400005	DIN71412-A G1/8 304	Grease nipple	1	1	1	1
4	3181100610	MT85007	Pressure lubricator connector	1	1	1	1

AXLE ASSEMBLY

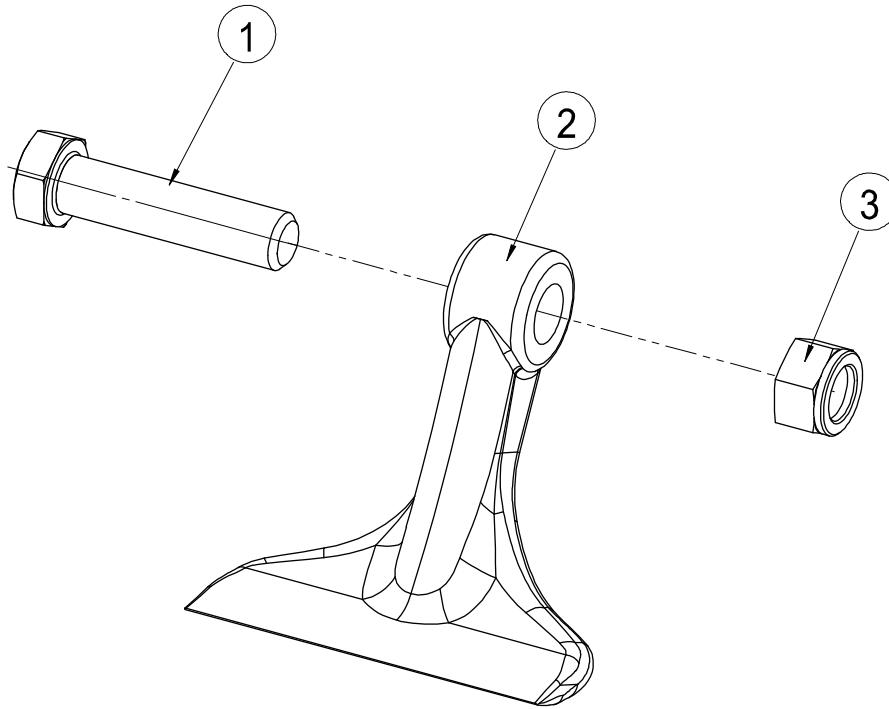

POS.	COD.	Specification	Description	Qty
1	3040300608	GB/T5782-M12×50-10.9-O	Hexagon head bolts	1
2	3220100034	MT01020	Blade	1
3	3050500007	GB/T889.1-M12-8-EP•Zn	Locknut	1

AXLE ASSEMBLY

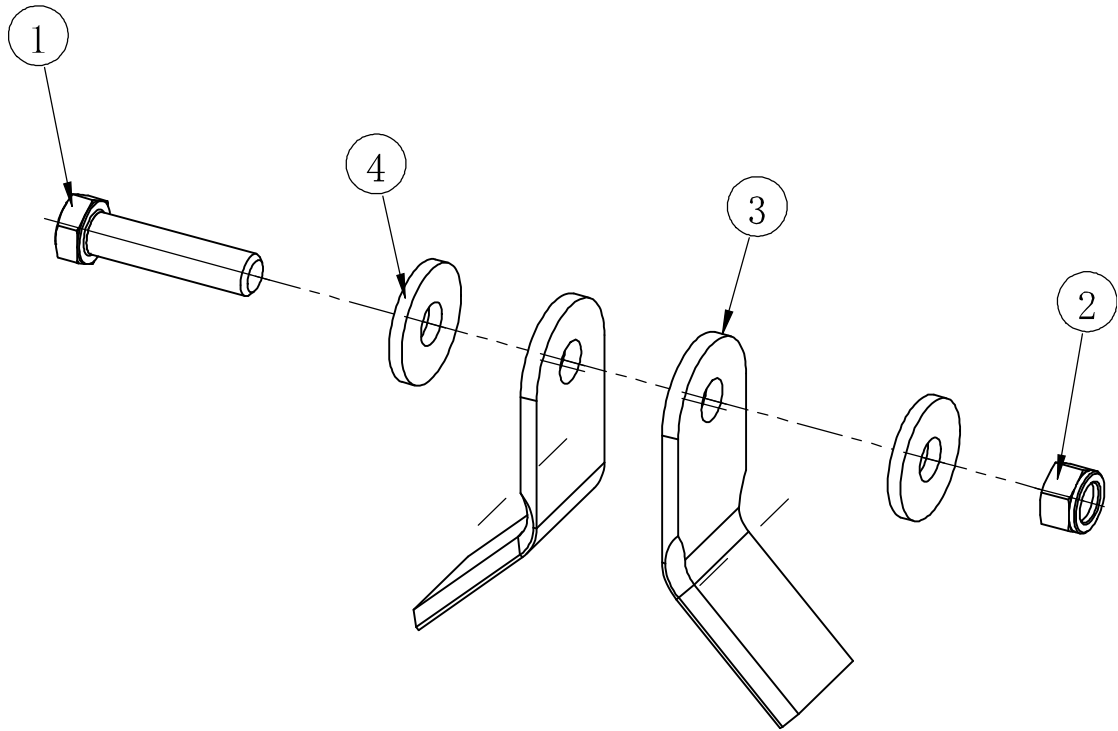

POS.	COD.	Specification	Description	Qty
1	3040300608	GB/T5782-M12×50-10.9-O	Hexagon head bolts	1
2	3050500007	GB/T889.1-M12-8-EP•Zn	Locknut	1
3	3220100027	MT02011	Blade	2
4	2000000001	G01009B02200-001	Blade spacer	2

ROLLER ASSEMBLY

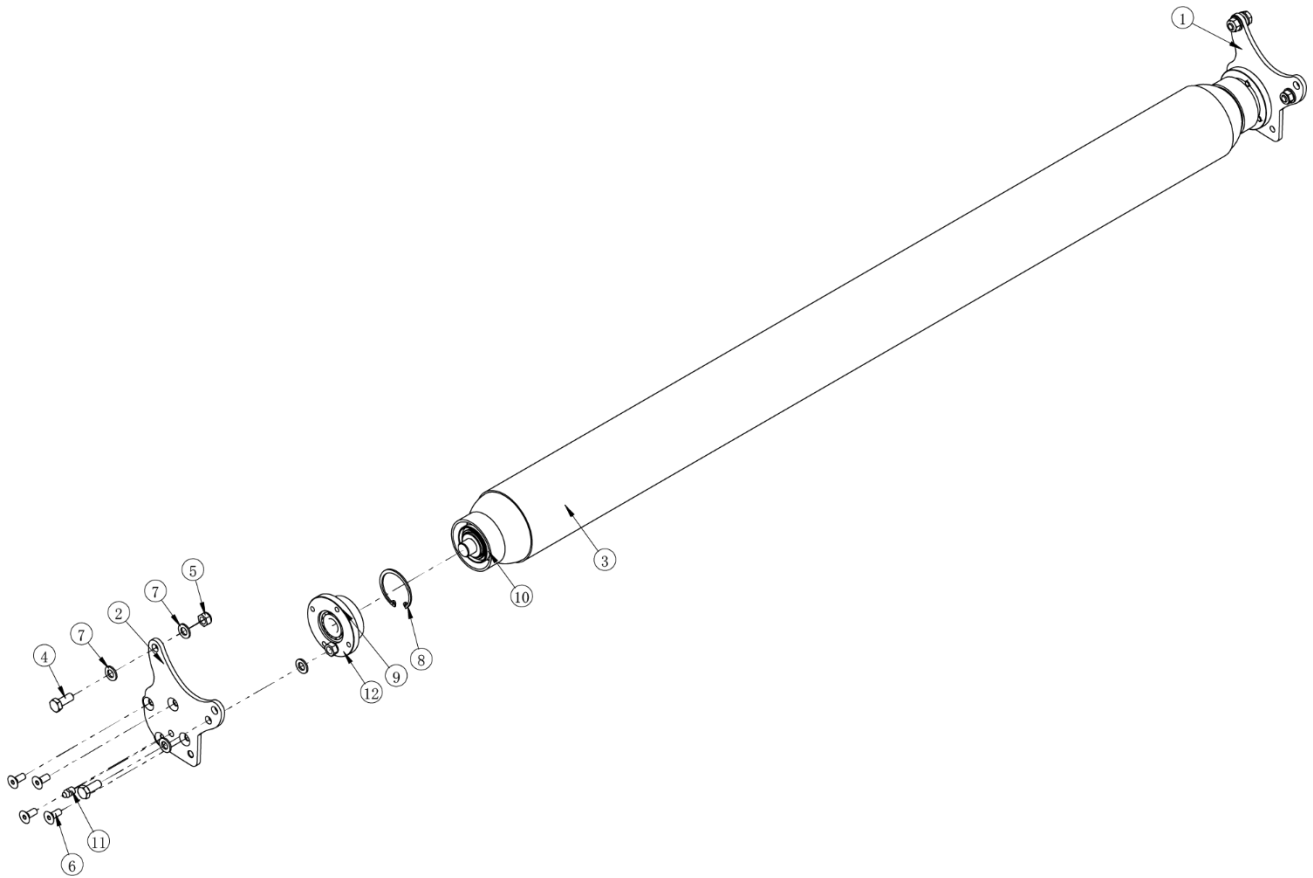

POS.	COD.	Specification	Description	VS40/ Qty	VS48/ Qty	VS58/ Qty	VS64/ Qty
1	2000000269	G01009A03000-002	Roller mounting plate-L	1	1	1	1
2	2000000270	G01009A03000-003	Roller mounting plate-R	1	1	1	1
3	2020000495	G01012A03100-000	Roller weldment	-	-	-	1
3	2020000494	G01011A03100-000	Roller weldment	-	-	1	-
3	2020000493	G01010A03100-000	Roller weldment	-	1	-	-
3	2020000492	G01009A03100-000	Roller weldment	1	-	-	-
4	3040100043	GB/T5783-M10×25-8.8-EP•Zn	Full-thread hexagon bolts	4	4	4	4
5	3050500004	GB/T889.1-M10-8-EP•Zn	Locknut	4	4	4	4
6	3060200018	GB/T70.3-M8×20-8.8-EP•Zn	HSCS-Countersunk	8	8	8	8

7	3080100006	GB/T95-10-EP•Zn	Plain washer	8	8	8	8
8	3080600033	GB/T893-52-A	Circlips for holes	2	2	2	2
9	3100200006	GB/T281-1304	Self-aligning ball bearing	2	2	2	2
10	3170100007	GB/T13871.1-FB-35 ×52×8-NBR	shaft seal	2	2	2	2
11	3170400005	DIN71412-A G1/8 304	Grease nipple	2	2	2	2
12	3240300005	G01009A03000-001	Bearing Block	2	2	2	2

BEARING SEAT ASSEMBLY

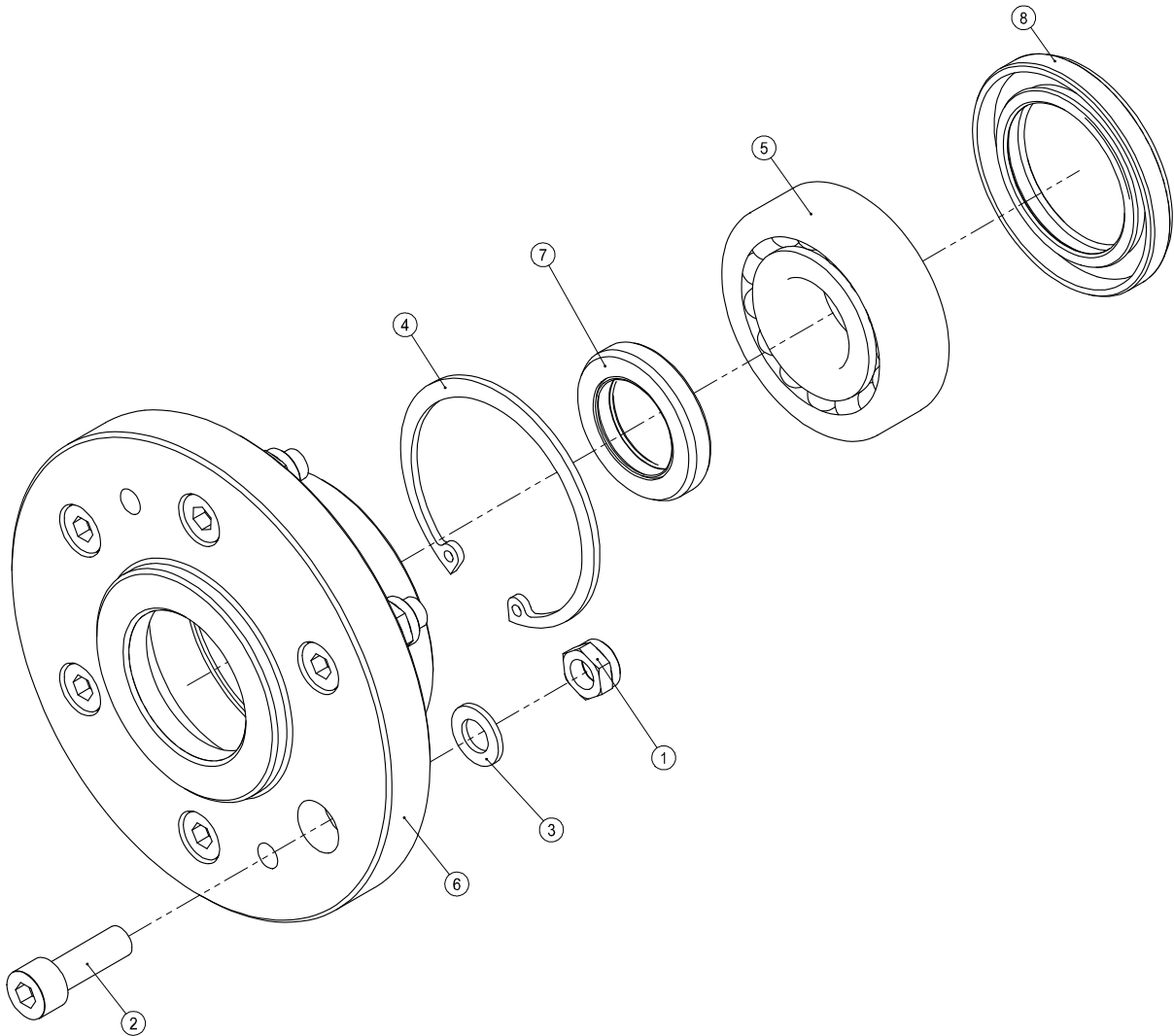

POS	COD.	Specification	Description	Qty
1	3050500003	GB/T889.1-M8-8-EP•Zn	Locknut	6
2	3060100027	GB/T70.1-M8×25-8.8-EP•Zn	Hexagon socket head cap screws	6
3	3080100004	GB/T95-8-EP•Zn	Plain washer	6
4	3080600038	GB/T893-62-A	Circlips for holes	1
5	3100200007	GB/T281-1305	Self-aligning ball bearing	1
6	3150100010	G01009A04000-001	Bearing seat	1
7	3170100003	GB/T13871.1-FB-25×40×7-NBR	shaft seal	1
8	3170100018	GB/T13871.1-FB-40×62×8-NBR	shaft seal	1

BEARING SEAT ASSEMBLY

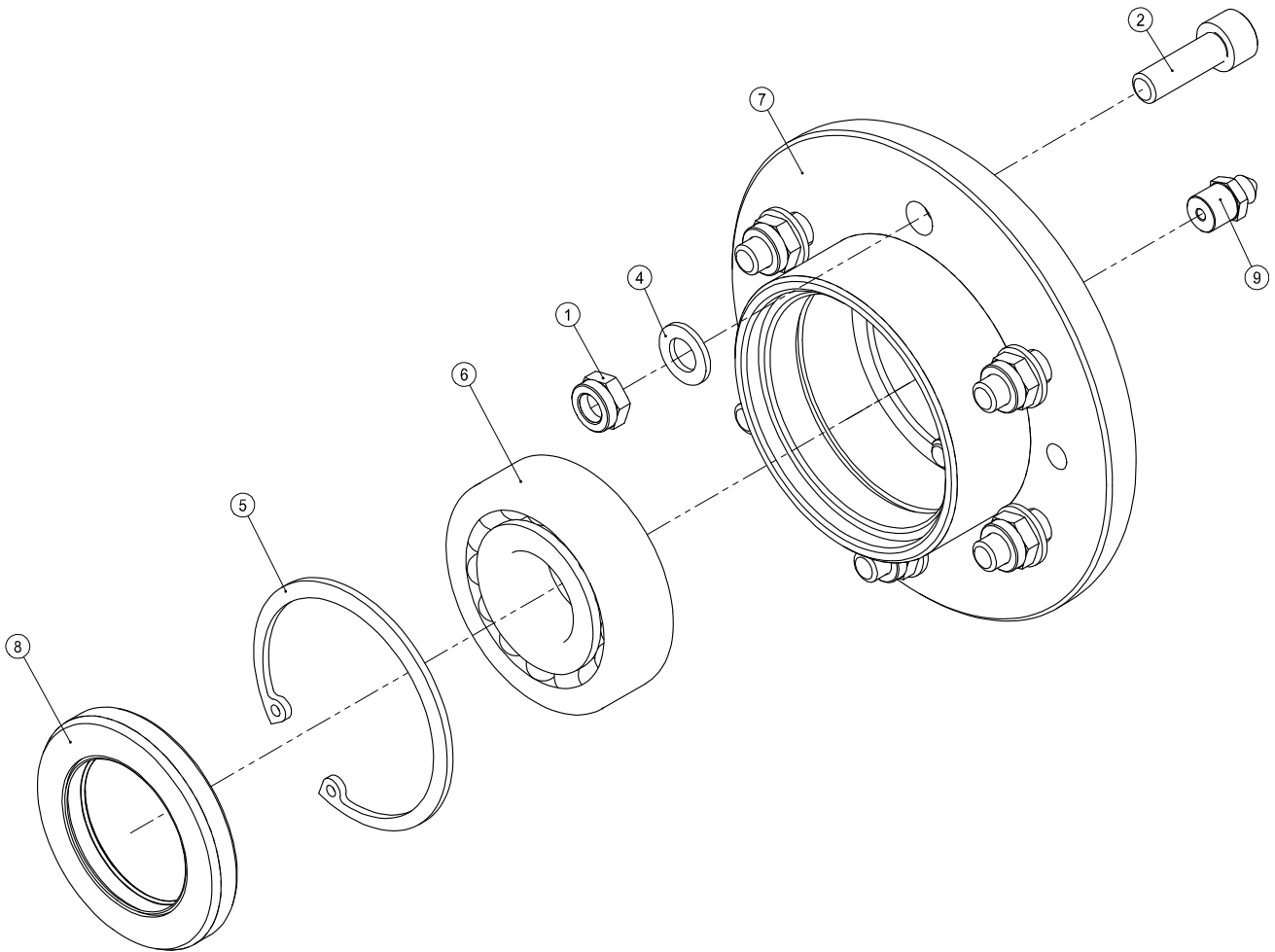

POS.	COD.	Specification	Description	Qty
1	3050500003	GB/T889.1-M8-8-EP•Zn	Locknut	6
2	3060100027	GB/T70.1-M8×25-8.8-EP•Zn	Hexagon socket head cap screws	6
3	3060400006	GB/T77-M8×8-45H-EP•Zn	Hexagon socket screws with flat point	2
4	3080100004	GB/T95-8-EP•Zn	Plain washer	6
5	3080600038	GB/T893-62-A	Circlips for holes	1
6	3100200007	GB/T281-1305	Self-aligning ball bearing	1
7	3150100009	G01009A05000-001	Bearing seat	1
8	3170100018	GB/T13871.1-FB-40×62×8-NBR	shaft seal	1
9	3170400005	Din71412-G1/8-A	Grease nipple	1

COVERING PLATE ASSEMBLY

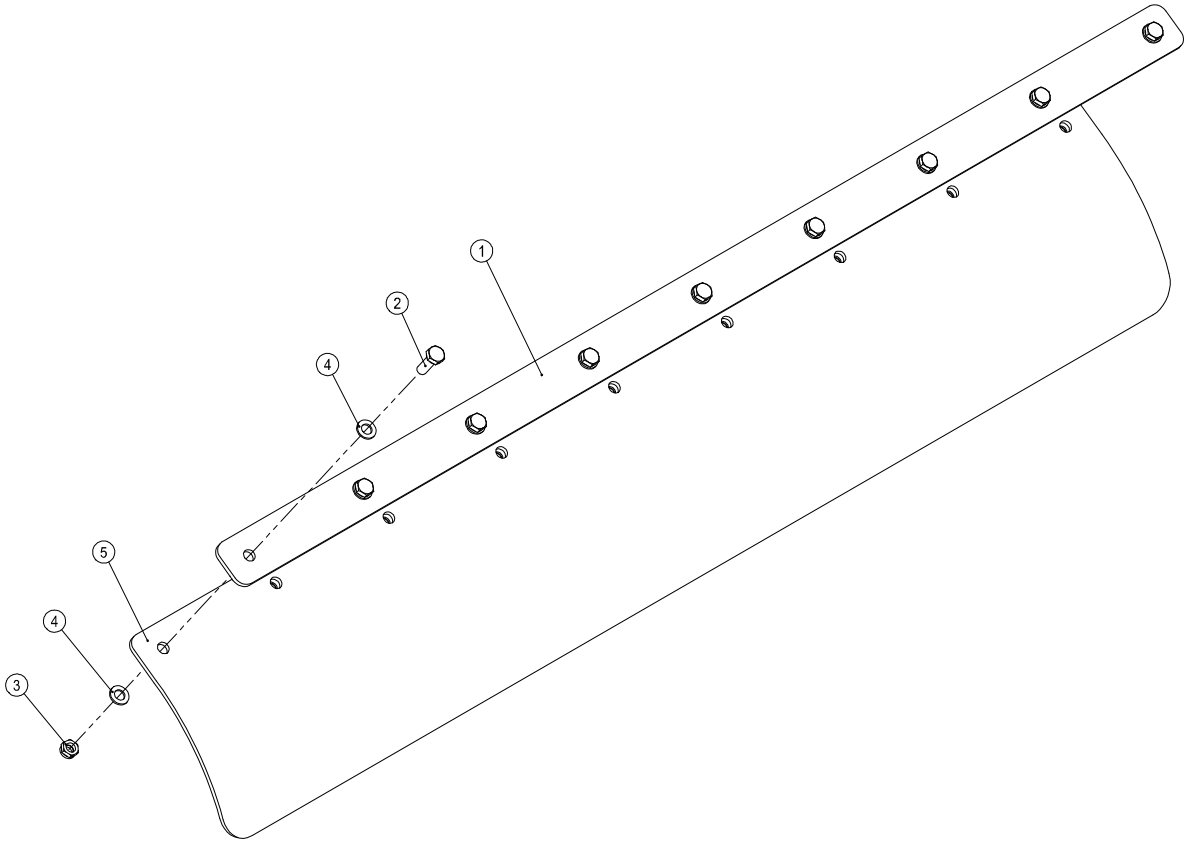

POS.	COD.	Specification	Description	VS40/ Qty	VS48/ Qty	VS58/ Qty	VS64/ Qty
1	2000000274	G01012A06000-001	Plate	-	-	-	1
1	2000000273	G01011A06000-001	Plate	-	-	1	-
1	2000000272	G01010A06000-001	Plate	-	1	-	-
1	2000000271	G01009A06000-001	Plate	1	-	-	-
2	3040100025	GB/T5783-M8×30-8.8-EP •Zn	Full-thread hexagon bolts	9	11	11	11
3	3050500003	GB/T889.1-M8-8-EP•Zn	Locknut	9	11	11	11
4	3080100004	GB/T95-8-EP•Zn	Plain washer	18	22	22	22
5	3210600006	G01012A06000-002	Rubber sheet	-	-	-	1
5	3210600005	G01011A06000-002	Rubber sheet	-	-	1	-
5	3210600004	G01010A06000-002	Rubber sheet	-	1	-	-
5	3210600003	G01009A06000-002	Rubber sheet	1	-	-	-

SIDE DRIVE ASSEMBLY

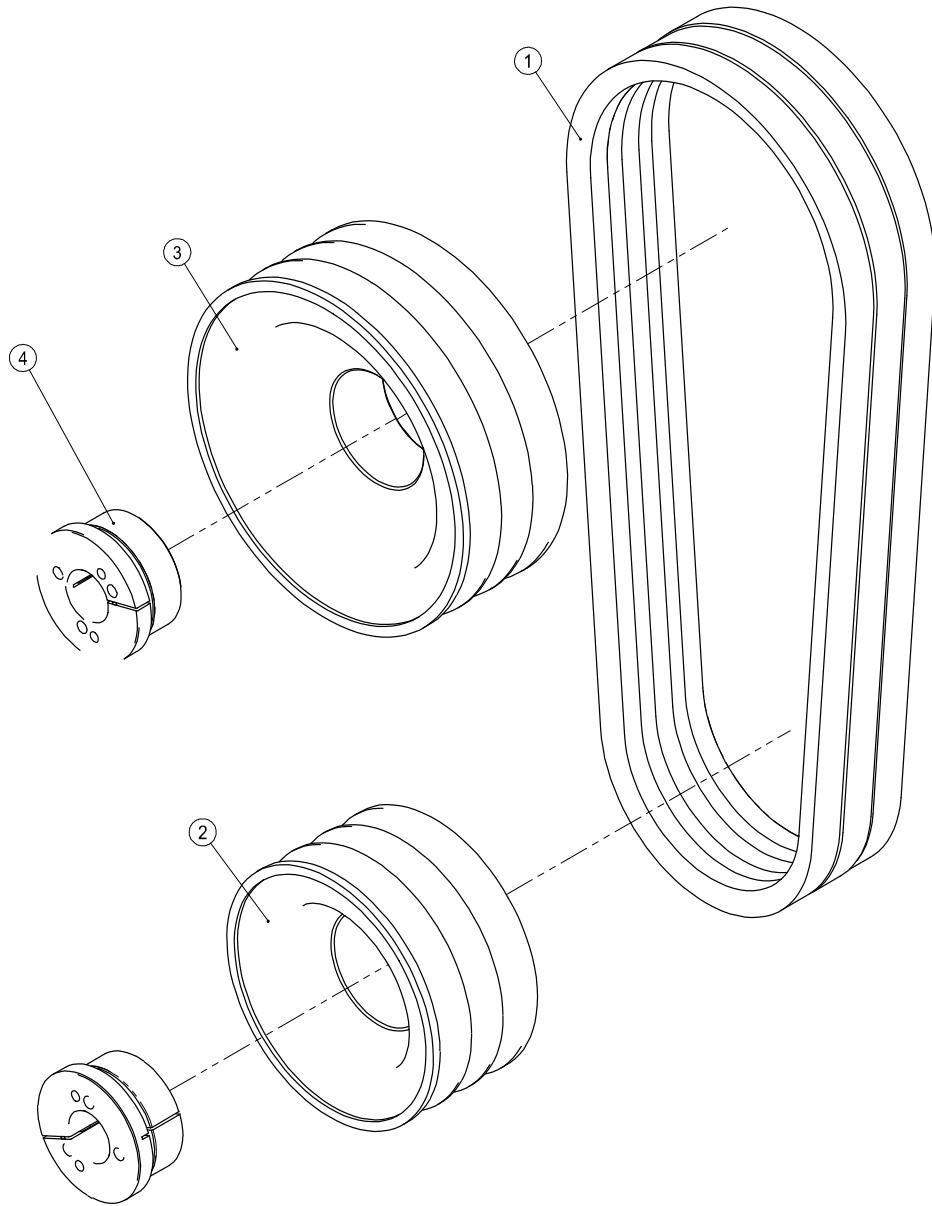

POS.	COD.	Specification	Description	Qty
1	3160300009	GATES-5LXP1010	Belt	3
2	3160400019	SPB118-3-1-55-HT200-O	Pulley	1
3	3160400020	SPB160-3-1-55-HT200-O	Pulley	1
4	3160500003	Z6-25×55	Expanding sleeve	2

SIDE COVER ASSEMBLY

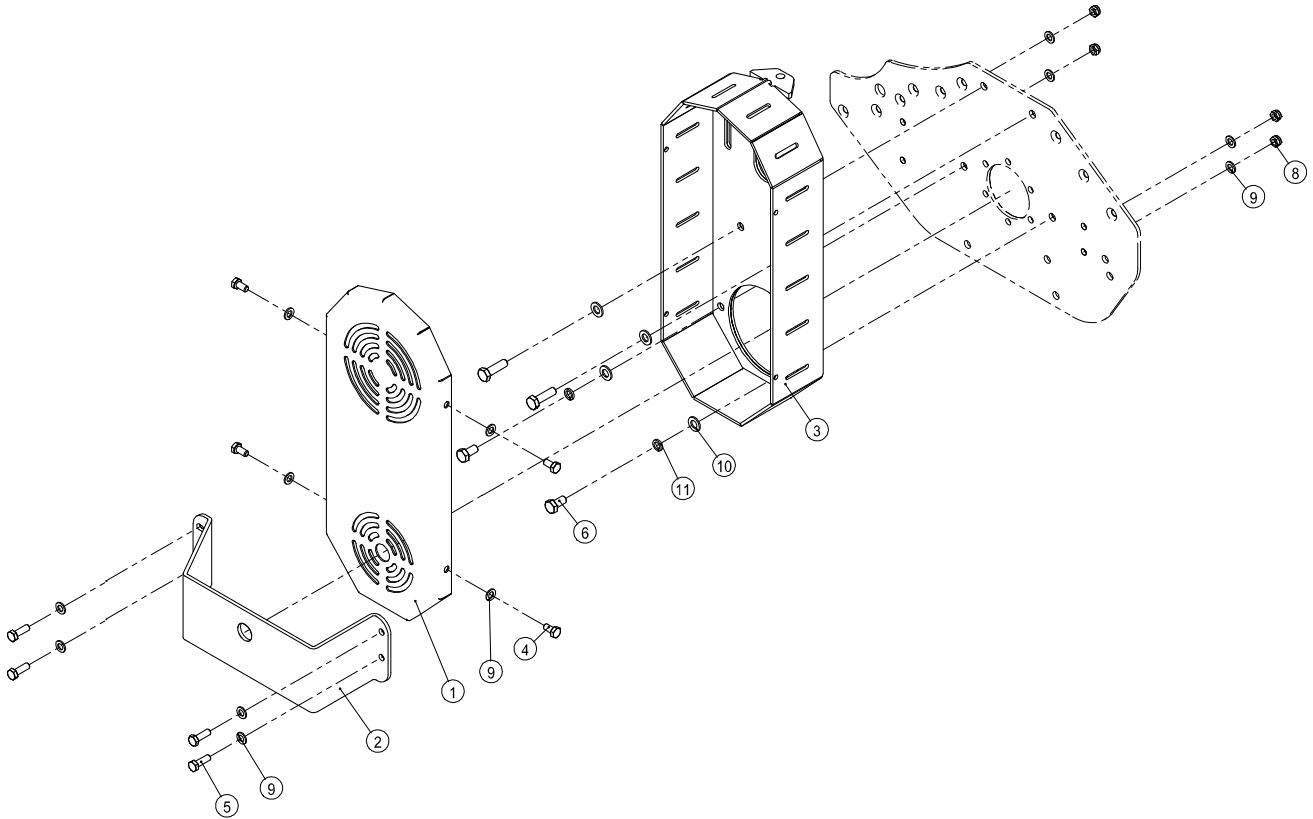

POS.	COD.	Specification	Description	Qty
1	2000000259	G01009A11000-001	Belt cover	1
2	2000000278	G01009A11000-002	Plate	1
3	2020000496	G01009A11100-000	Pulley cover weldment	1
4	3040100021	GB/T5783-M8×16-8.8-EP•Zn	Full-thread hexagon bolts	4
5	3040100024	GB/T5783-M8×25-8.8-EP•Zn	Full-thread hexagon bolts	4
6	3040100041	GB/T5783-M10×20-8.8-EP•Zn	Full-thread hexagon bolts	2
7	3040100046	GB/T5783-M10×35-8.8-EP•Zn	Full-thread hexagon bolts	2
8	3050500003	GB/T889.1-M8-8-EP•Zn	Locknut	4
9	3080100004	GB/T95-8-EP•Zn	Plain washer	12
10	3080100006	GB/T95-10-EP•Zn	Plain washer	4
11	3080500008	GB/T93-10-EP•Zn	Spring washer	2

SKID PLATE ASSEMBLY

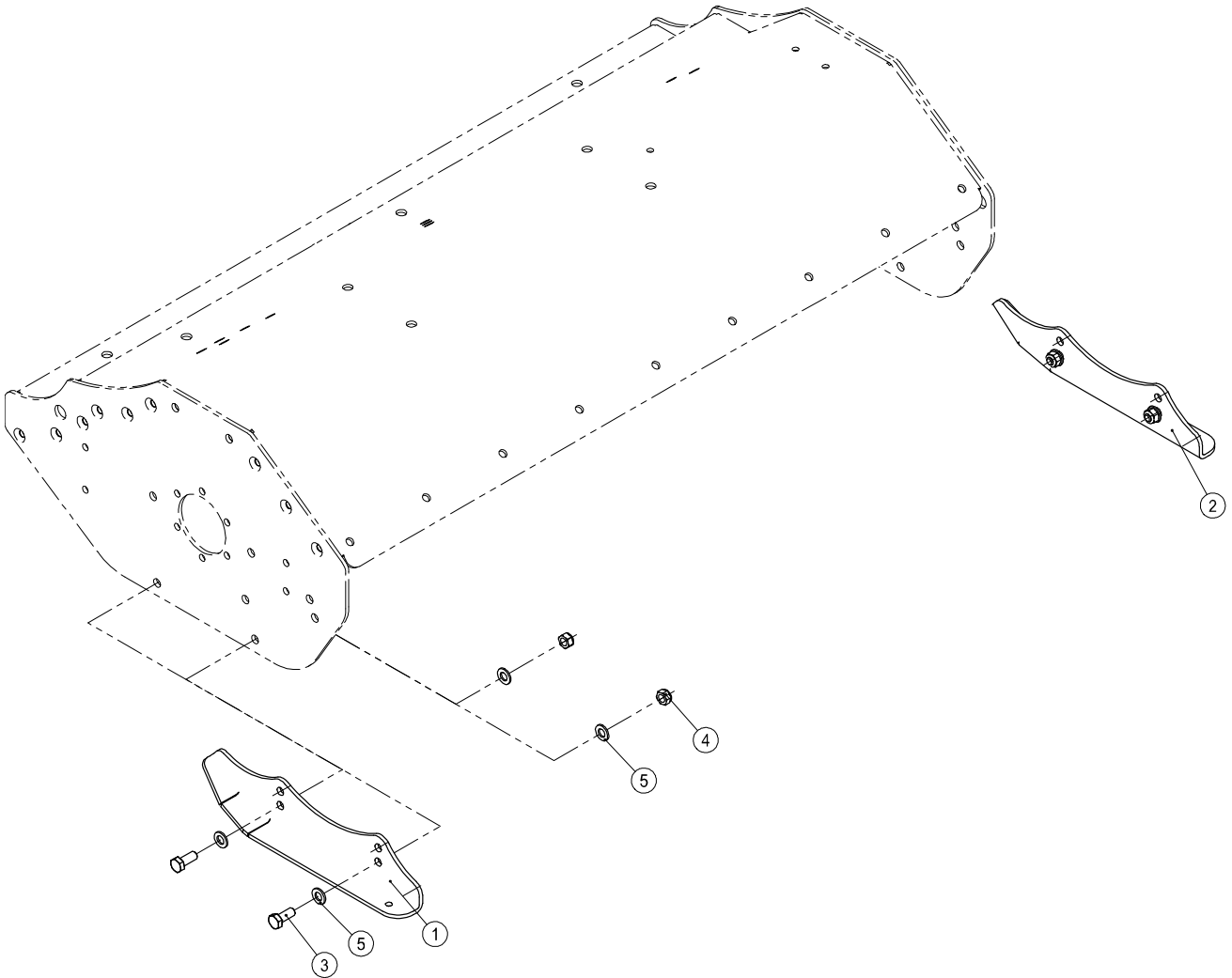

POS.	COD.	Specification	Description	Qty
1	2000000252	G01009A14000-002	Skate-L	1
2	2000000253	G01009A14000-001	Skate-R	1
3	3040100043	GB/T5783-M10×25-8.8-EP•Zn	Full-thread hexagon bolts	4
4	3050500004	GB/T889.1-M10-8-EP•Zn	Locknut	4
5	3080100006	GB/T95-10-EP•Zn	Plain washer	8

SCRAPER ASSEMBLY

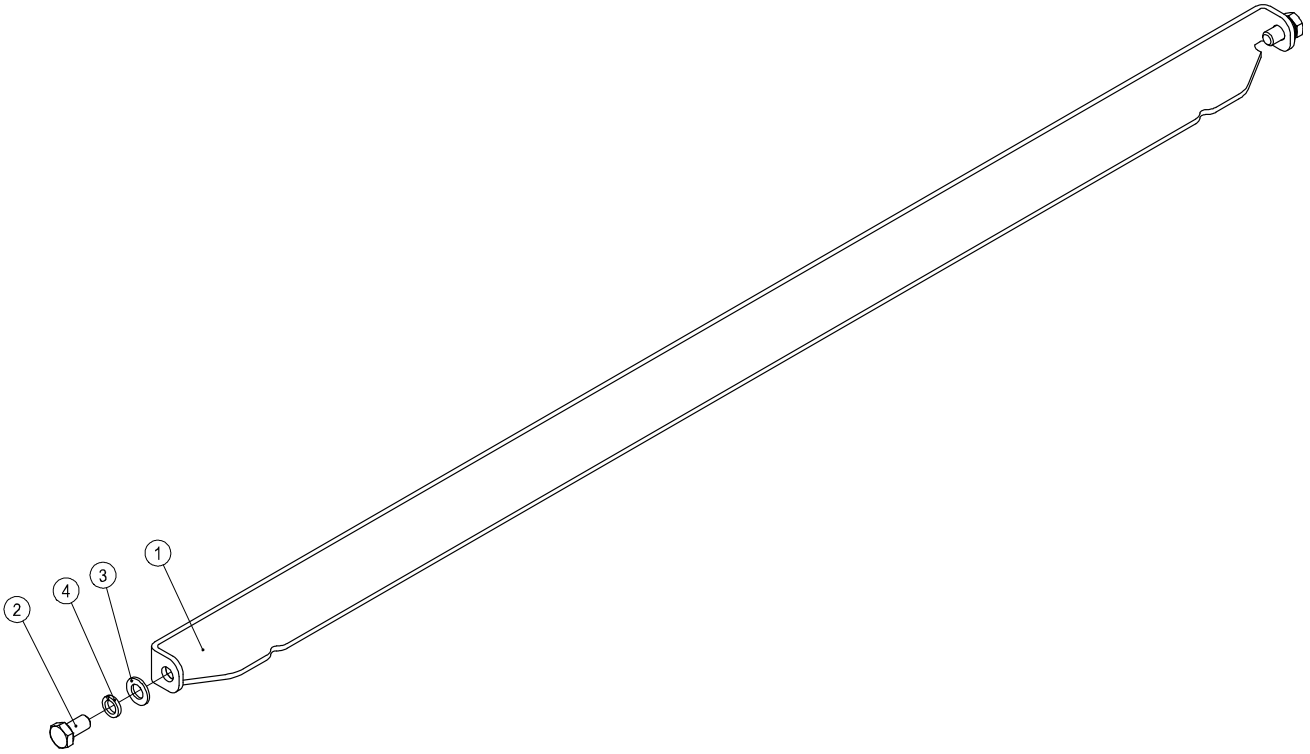

POS.	COD.	Specification	Description	VS40/ Qty	VS48/ Qty	VS58/ Qty	VS64/ Qty
1	2000000263	G01012A1700 0-001	Scraper	-	-	-	1
1	2000000262	G01011A1700 0-001	Scraper	-	-	1	-
1	2000000261	G01010A1700 0-001	Scraper	-	1	-	-
1	2000000260	G01009A1700 0-001	Scraper	1	-	-	-
2	3040100041	GB/T5783-M10×20- 8.8-EP•Zn	Full-thread hexagon bolts	2	2	2	2
3	3080100006	GB/T95-10-EP•Zn	Plain washer	2	2	2	2
4	3080500008	GB/T93-10-EP•Zn	Spring washer	2	2	2	2

PROTECTIVE ASSEMBLY

G.OS105:

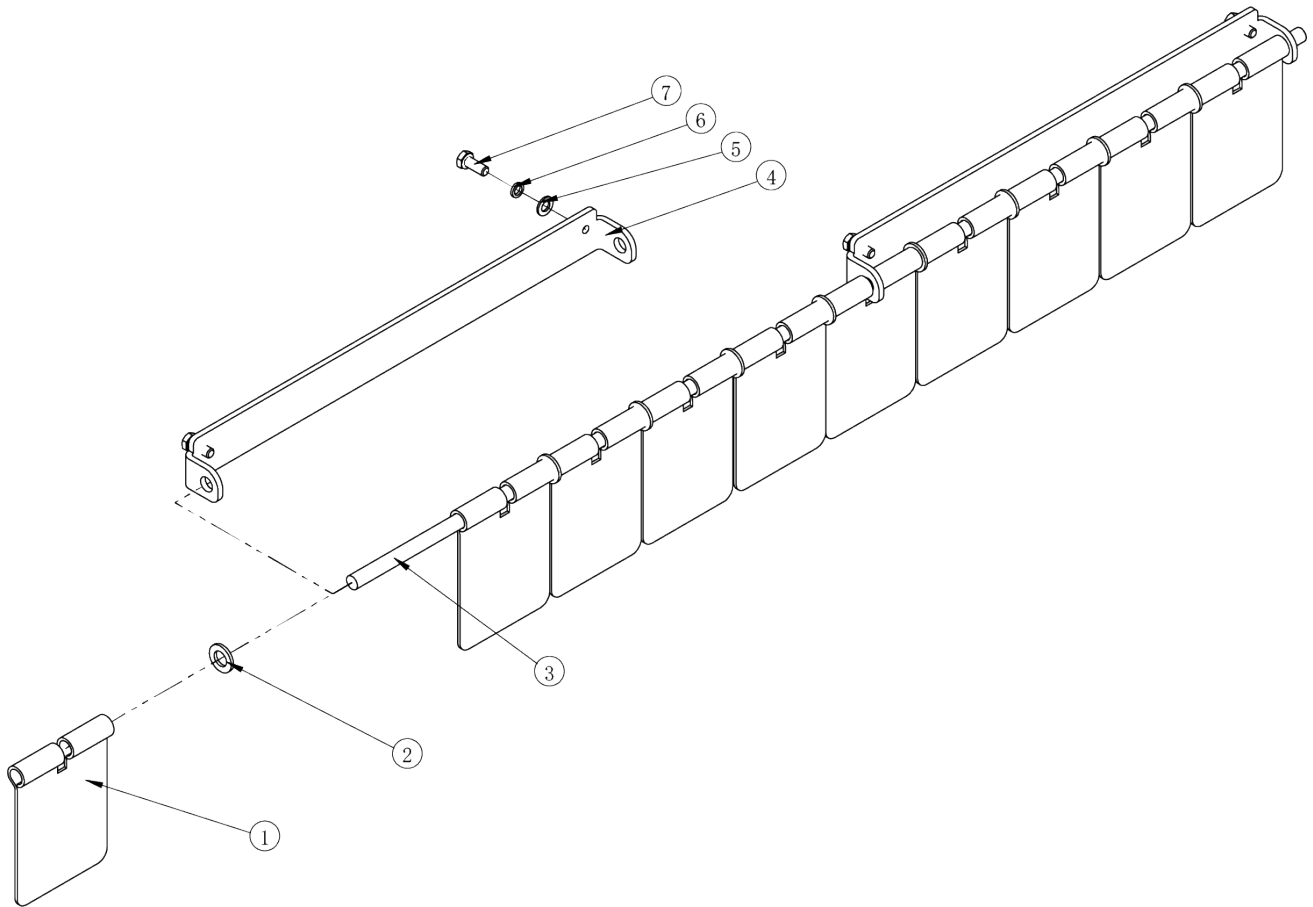

POS.	COD.	Specification	Description	Qty
1	2000000190	G01009A15000-003	Baffle with cut	10
2	3080100007	GB/T95-12-EP•Zn	Plain washer	13
3	2010000170	G01009A15000-002	Baffle axle	1
4	2000006842	G02007A15000-001	Baffle sustaining plate	2
5	3080100004	GB/T95-8-EP•Zn	Plain washer	4
6	3080500007	GB/T93-8-EP•Zn	Spring washer	4
7	3040100022	GB/T5783-M8×20-8.8-EP•Zn	Full-thread hexagon bolts	4

G.OS125-165

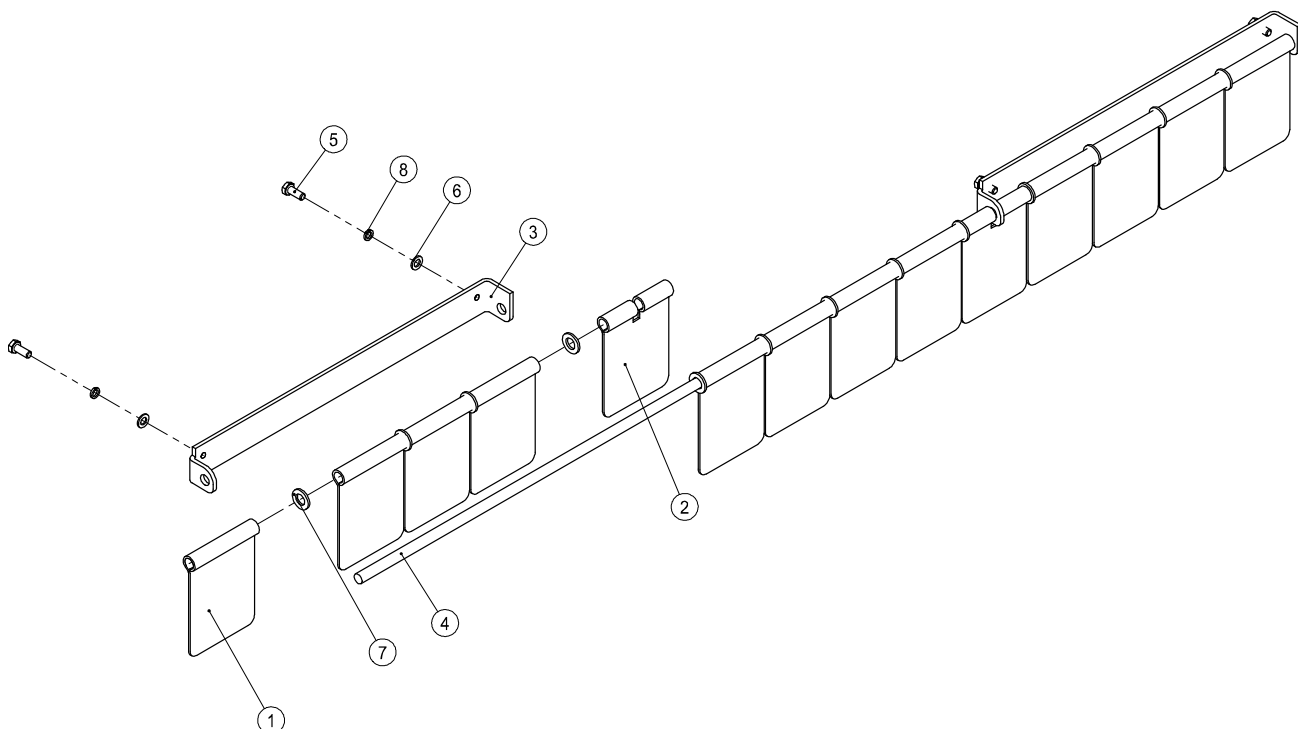

POS	COD.	Specification	Description	VS48/ Qty	VS58/ Qty	VS64/ Qty
1	2000000189	G01009A15000-004	Baffle	10	12	14
2	2000000190	G01009A15000-003	Baffle with cut	2	2	2
3	2000000265	G01009A15000-001	Baffle sustaining plate	2	2	2
4	2010000173	G01012A15000-002	Baffle axle	-	-	1
4	2010000172	G01011A15000-002	Baffle axle	-	1	-
4	2010000171	G01010A15000-002	Baffle axle	1	-	-
4	2010000170	G01009A15000-002	Baffle axle	-	-	-
5	3040100023	GB/T5783-M8×20-10.9-EP•Zn	Full-thread hexagon bolts	4	4	4
6	3080100004	GB/T95-8-EP•Zn	Plain washer	4	4	4
7	3080100007	GB/T95-12-EP•Zn	Plain washer	11	13	15
8	3080500007	GB/T93-8-EP•Zn	Spring washer	4	4	4

SWING ASSEMBLY

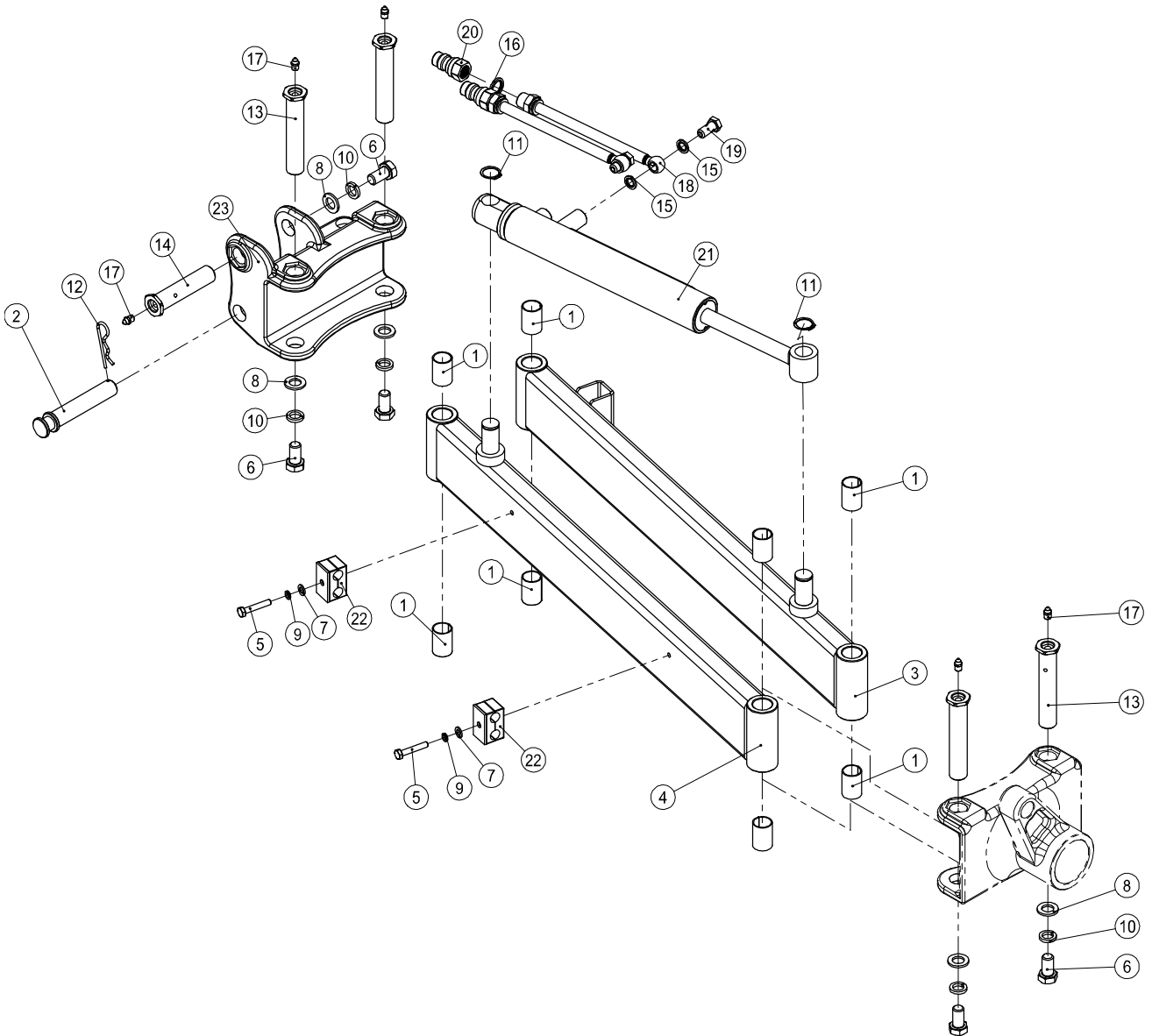

POS.	COD.	Specification	Description	Qty
1	3100900004	SF-2-25×28×40	Bushings	8
2	2010000045	G02001A18000-003	Pin	1
3	2020000499	G02001A18200-000	Swing square pipe-L	1
4	2020000500	G02001A18100-000	Swing square pipe-R	1
5	3040100028	GB/T5783-M8×45-8.8-EP•Zn	Full-thread hexagon bolts	2
6	3040100104	GB/T5783-M16×30-8.8-EP•Zn	Full-thread hexagon bolts	5
7	3080100004	GB/T95-8-EP•Zn	Plain washer	2
8	3080100009	GB/T95-16-EP•Zn	Plain washer	5

9	3080500007	GB/T93-8-EP•Zn	Spring washer	2
10	3080500011	GB/T93-16-EP•Zn	Spring washer	5
11	3080700016	GB/T894-25-A	Retaining rings for shaft	2
12	3120400008	Din11024-4-EP•Zn	R Pin	1
13	3120500012	G02001A18000-001	Pin	4
14	3120500016	G02001A18000-002	Pin	1
15	3170300001	BS/A-13.7×20.6×2-Q235	Combined sealing gaskets	4
16	3170300006	BS/A-21.5×28.6×2.5-Q235	Combined sealing gaskets	2
17	3170400005	Din71412-G1/8-A	Grease nipple	5
18	3180200254	2SN06BL×O20310-04-04/M10610-04-08×1800+04	Hose	2
19	3180300009	G1/4-28.5-6-22	Hollow bolt	2
20	3180500001	Q00211041A-08-08	Hollow bolt	2
21	3181300036	CDL1MP5-40/22/243-D-G1/4-1CGUM	Hydraulic cylinder	1
22	3210100005	2-Φ16	Pipe Clamp	2
23	3220300023	G02001A18300-000	Lifting connector	1

REVERSE ASSEMBLY

ME-VS40

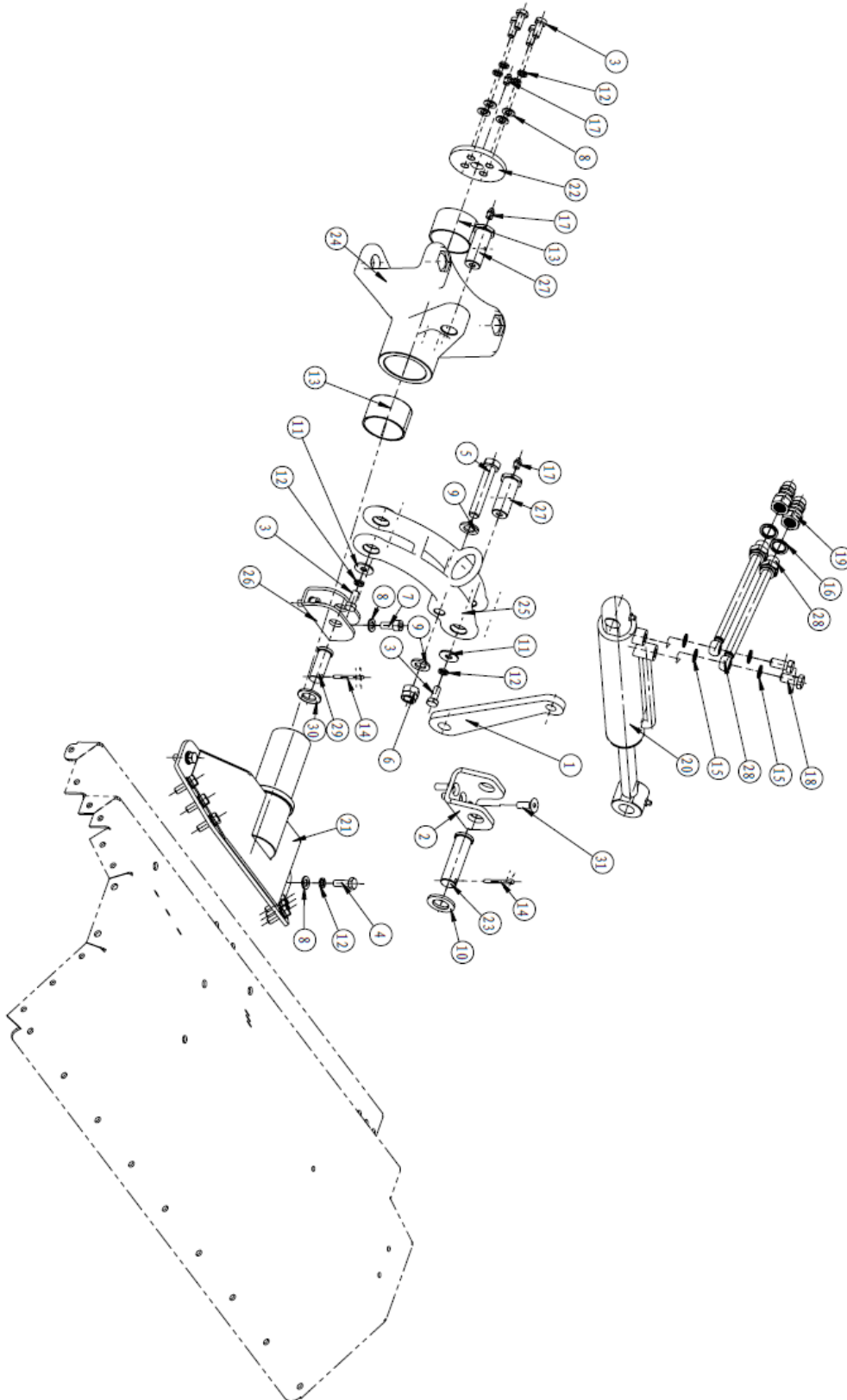

POS	COD.	Specification	Description	Qty
1	2000006809	G02007A19000-003	Linkage plate	1
2	2000006808	G02007A19000-004	Overturning retainer	1
3	3040100043	GB/T5783-M10×25-8.8-EP•Zn	Full-thread hexagon bolts	6
4	3040100045	GB/T5783-M10×30-8.8-EP•Zn	Full-thread hexagon bolts	8
5	3040100120	GB/T5783-M16×90-8.8-EP•Zn	Full-thread hexagon bolts	1
6	3050500009	GB/T889.1-M16-8-EP•Zn	Locknut	1
7	3060100039	GB/T70.1-M10×25-8.8-EP•Zn	Hexagon socket head cap screws	2
8	3080100006	GB/T95-10-EP•Zn	Plain washer	14
9	3080100009	GB/T95-16-EP•Zn	Plain washer	2
10	3080100013	GB/T95-24-EP•Zn	Plain washer	1
11	3080200009	GB/T96.2-10-EP•Zn	Large plain washer	2
12	3080500008	GB/T93-10-EP•Zn	Spring washer	14
13	3100900013	SF-2-63×68×40	Bushings	2
14	3120100107	GB/T91-5×40	Split pin	2
15	3170300001	BS/A-13.7×20.6×2-Q235	Combined sealing gaskets	4
16	3170300006	BS/A-21.5×28.6×2.5-Q235	Combined sealing gaskets	2
17	3170400005	DIN71412-A G1/8 304	Grease nipple	3
18	3180300009	G1/4-28.5-6-22	Hollow bolt	2
19	3180500001	Q00211041A-08-08	Hollow bolt	2
20	3181300137	CDL1MP5-50_25_246-D-G1_4-1CGUM	Hydraulic cylinder	1
21	2020000487	G02001A19100-000	Overturning shaft	1
22	2000000171	G02001A19000-001	Limiting plate	1
23	3120500015	G02001A19000-002	Pin	1
24	3220300024	G02001A19200-000	Overturning bracket	1
25	3220300025	G02001A19300-000	Overturning connecting bracket	1

26	200000276	G02001A19000-009	Sustaining seat	1
27	3120500013	G02001A19000-007	Pin	2
28	3180200253	2SN06BL × O20310-04-04/M10610-04-08 × 3080+04	Hose	2
29	3120500014	G02001A19000-008	Pin	1
30	3080100011	GB/T95-20-EP•Zn	Plain washer	1
31	3060200034	GB/T70.3-M10×30-8.8-EP•Zn	HSCS-Countersunk	3

ME-VS48-64

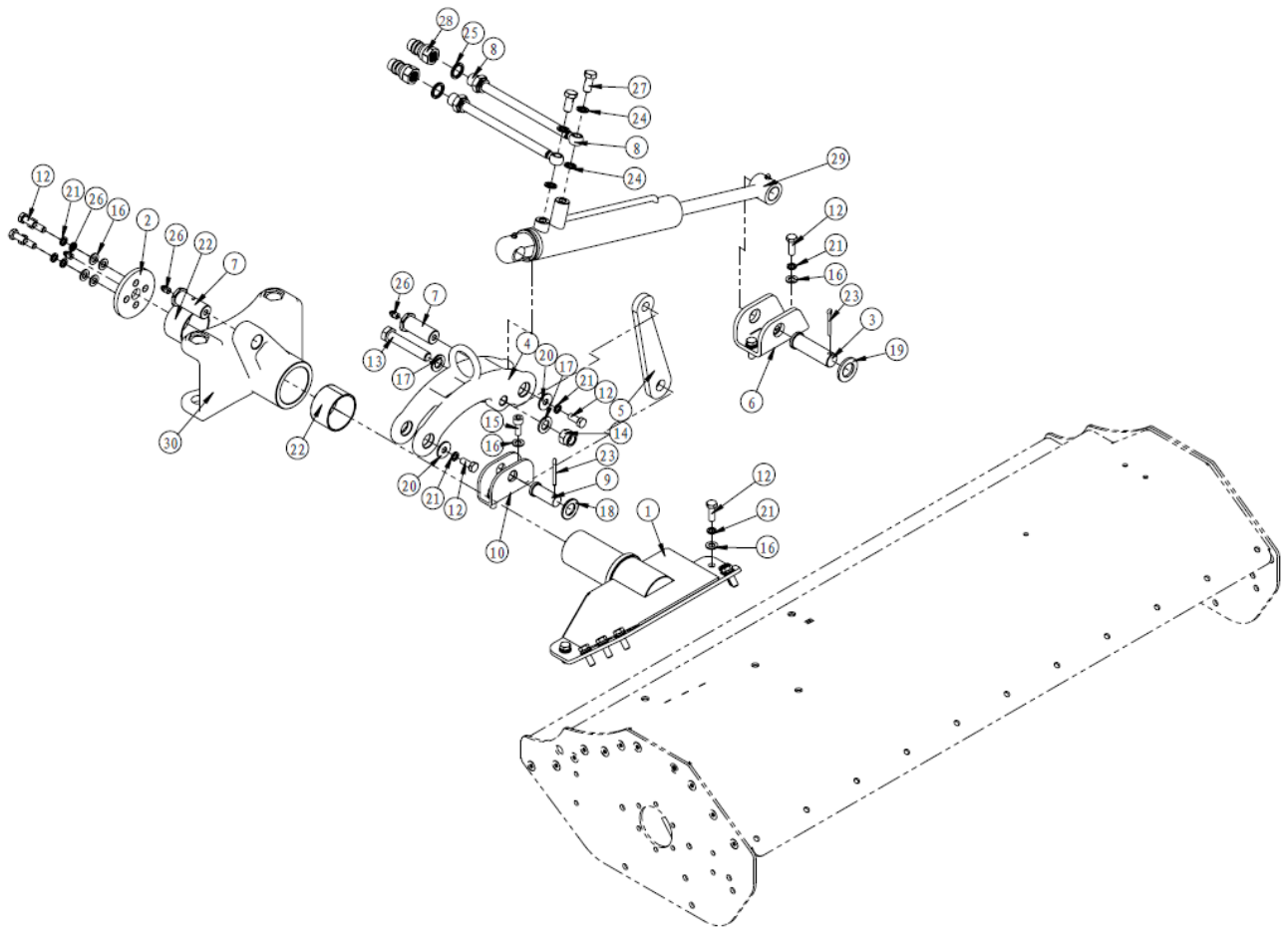

POS	COD.	Specification	Description	Qty
1	2020000487	G02001A19100-000	Overturning shaft	1
2	2000000171	G02001A19000-001	Limiting plate	1
3	3120500015	G02001A19000-002	Pin	1
4	3220300025	G02001A19300-000	Overturning connecting bracket	1

5	2000000170	G02001A19000-003	Linkage plate	1
6	2000000258	G02001A19000-004	Overturning retainer	1
7	3120500013	G02001A19000-007	Pin	2
8	3180200253	2SN06BL×O20310-04-04/M10610-04-08× 3080+04	Hose	2
9	3120500014	G02001A19000-008	Pin	1
10	2000000276	G02001A19000-009	Sustaining seat	1
12	3040100043	GB/T5783-M10×25-8.8-EP•Zn	Full-thread hexagon bolts	6
12	3040100045	GB/T5783-M10×30-8.8-EP•Zn	Full-thread hexagon bolts	11
13	3040100120	GB/T5783-M16×90-8.8-EP•Zn	Full-thread hexagon bolts	1
14	3050500009	GB/T889.1-M16-8-EP•Zn	Locknut	1
15	3060100039	GB/T70.1-M10×25-8.8-EP•Zn	Hexagon socket head cap screws	2
16	3080100006	GB/T95-10-EP•Zn	Plain washer	17
17	3080100009	GB/T95-16-EP•Zn	Plain washer	2
18	3080100011	GB/T95-20-EP•Zn	Plain washer	1
19	3080100013	GB/T95-24-EP•Zn	Plain washer	1
20	3080200009	GB/T96.2-10-EP•Zn	Large plain washer	2
21	3080500008	GB/T93-10-EP•Zn	Spring washer	17
22	3100900013	SF-2-63×68×40	Bushings	2
23	3120100107	GB/T91-5×40	Split pin	2
24	3170300001	BS/A-13.7×20.6×2-Q235	Combined sealing gaskets	4
25	3170300006	BS/A-21.5×28.6×2.5-Q235	Combined sealing gaskets	2
26	3170400005	DIN71412-A G1/8 304	Grease nipple	3
27	3180300009	G1/4-28.5-6-22	Hollow bolt	2
28	3180500001	Q00211041A-08-08	Hollow bolt	2
29	3181300036	CDL1MP5-45/22/243-D-G1/4-1CGUM	Hydraulic cylinder	1
30	3220300024	G02001A19200-000	Overturning bracket	1

SUPPORTING ASSEMBLY

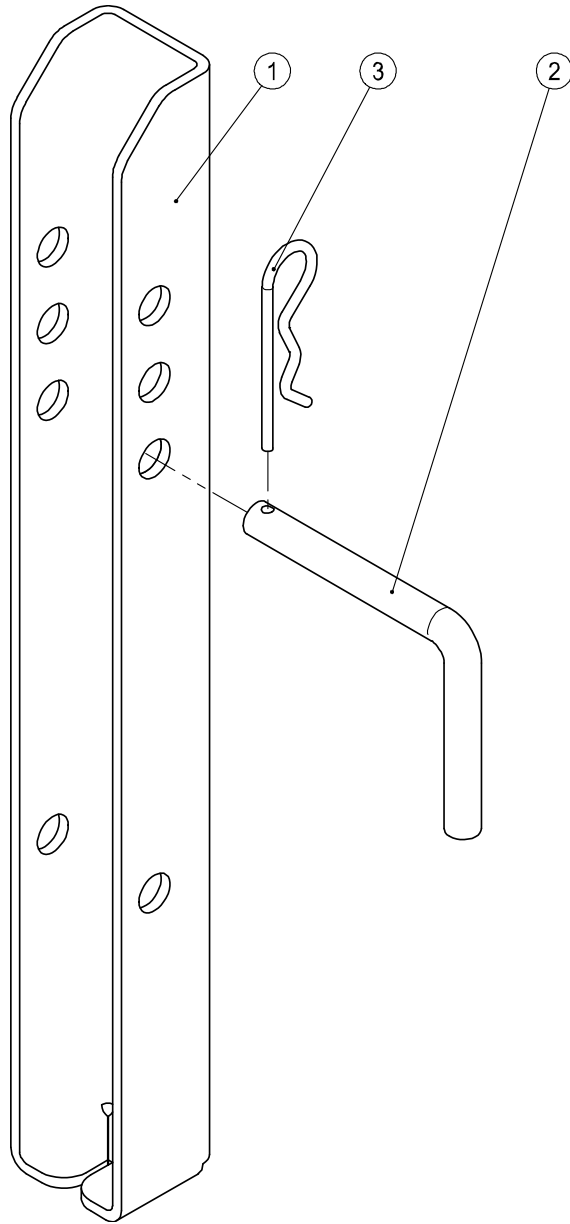

POS.	COD.	Specification	Description	Qty
1	2000000268	G02001A16000-001	Raker	1
2	2010000017	G01001A16000-001	Raker pin	1
3	3120400008	Din11024-4-EP•Zn	R Pin	1

HITCH ASSEMBLY

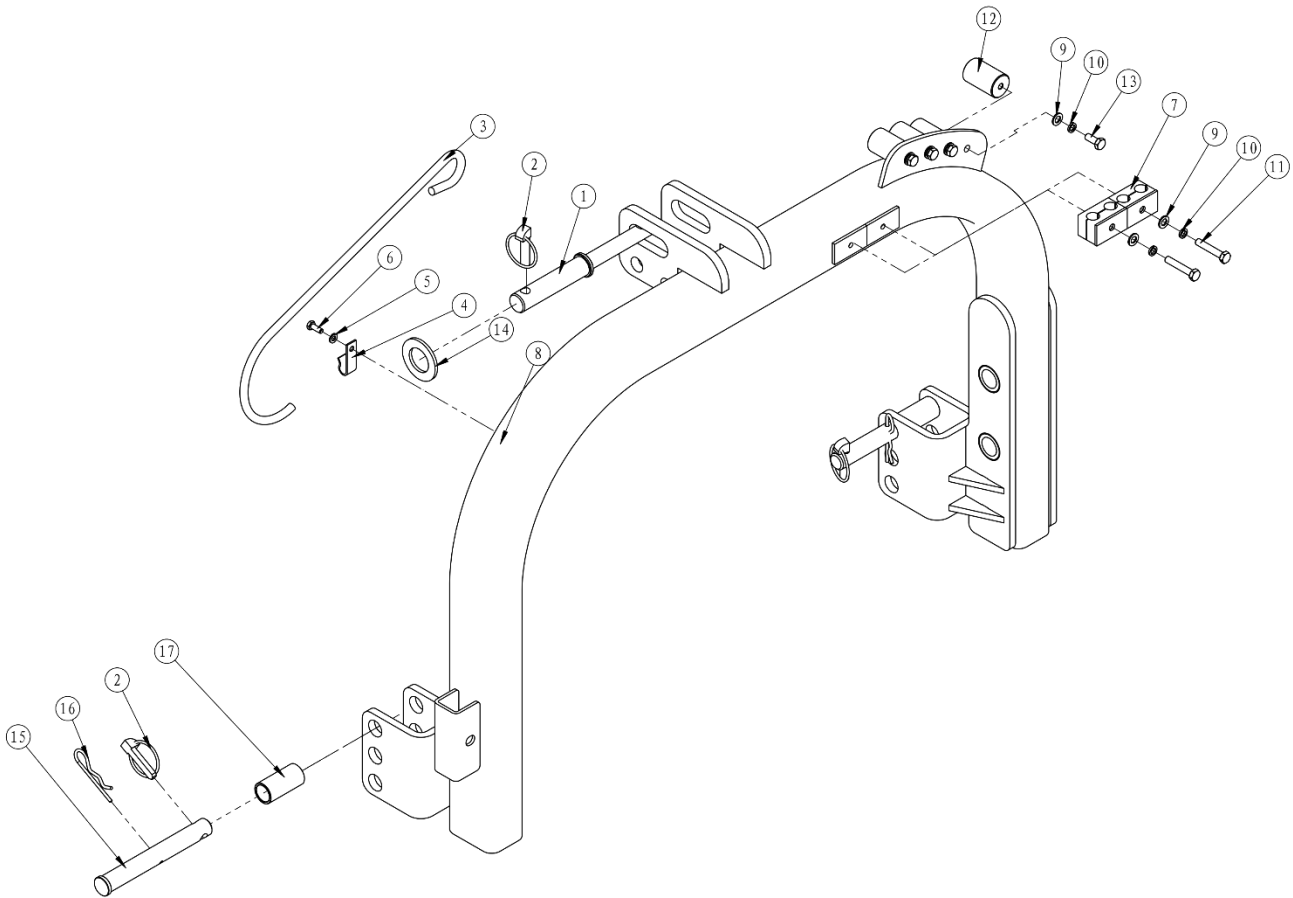

POS.	COD.	Specification	Description	Qty
1	3120500032	MT95008	Pin	1
2	3120400007	GB/T4329-12-EP•Zn	Pin	3
3	2010000028	W01006A01000-002	PTO shaft hook	1
4	3220400602	G02001A12000-001	Spring clasp	1
5	3080100003	GB/T95-6-EP•Zn	Plain washer	1
6	3040100005	GB/T5783-M6×16-8.8-EP•Zn	Full-thread hexagon bolts	1
7	3210100005	2-Φ 16	Pipe Clamp	2
8	2020000498	G02001A12100-000	Hitch weldment	1
9	3080100004	GB/T95-8-EP•Zn	Plain washer	6

10	3080500007	GB/T93-8-EP•Zn	Spring washer	6
11	3040100028	GB/T5783-M8×45-8.8-EP•Zn	Full-thread hexagon bolts	2
12	3210500035	LSQ-S1 MDC-1/2M	Rubber	4
13	3040100022	GB/T5783-M8×20-8.8-EP•Zn	Full-thread hexagon bolts	4
14	3080100015	GB/T95-30-EP•Zn	Plain washer	1
15	2010006568	G2007A12900-001	Pin	2
16	3120400008	Din11024-4-EP•Zn	R Pin	2
17	2010000778	F01001A12000-004	Spacer sleeve	2

GEARBOX DRIVE SHAFT ASSEMBLY

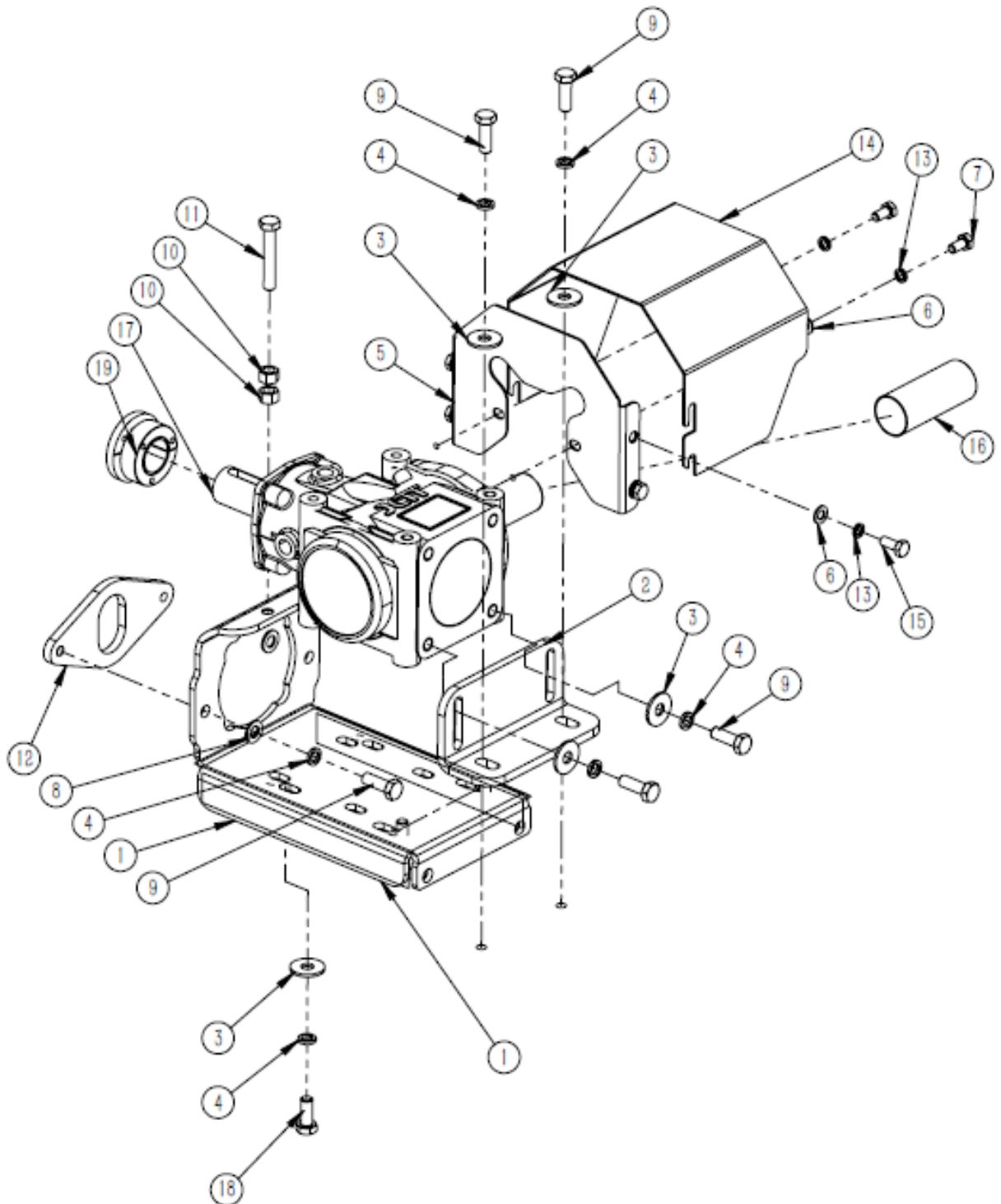

POS.	COD.	Specification	Description	Qty
1	2020006340	G02001D08100-000	Gearbox base plate welding	1
2	2000000002	G01009A08000-002	Gearbox bracket	1
3	3080200009	GB/T96.2-10-EP•Zn	Large plain washer	8
4	3080500008	GB/T93-10-EP•Zn	Spring washer	10
5	2020001787	G01009A08200-000	Weldment	1
6	3080100004	GB/T95-8-EP•Zn	Plain washer	6
7	3040100021	GB/T5783-M8×16-8.8-EP•Zn	Full-thread hexagon bolts	2
8	3080100006	GB/T95-10-EP•Zn	Plain washer	2
9	3040100045	GB/T5783-M10×30-8.8-EP•Zn	Full-thread hexagon bolts	6
10	3050100005	GB/T41-M10-5-EP•Zn	Hexagon Nuts	2
11	3040100051	GB/T5783-M10×60-8.8-EP•Zn	Full-thread hexagon bolts	1
12	2000000277	G01009A08000-004	Tension plate	1
13	3080500007	GB/T93-8-EP•Zn	Spring washer	6
14	2000000857	G01009A08000-001	PTO shaft protective cover	1
15	3040100022	GB/T5783-M8×20-8.8-EP•Zn	Full-thread hexagon bolts	4
16	3210500603	Φ 35×90	Rubber	1
17	3160100706	KF030R290Z0200	Gear box	1
18	3040100043	GB/T5783-M10×25-8.8-EP•Zn	Full-thread hexagon bolts	4
19	3160500004	Z6-30×55	Expanding sleeve	1