

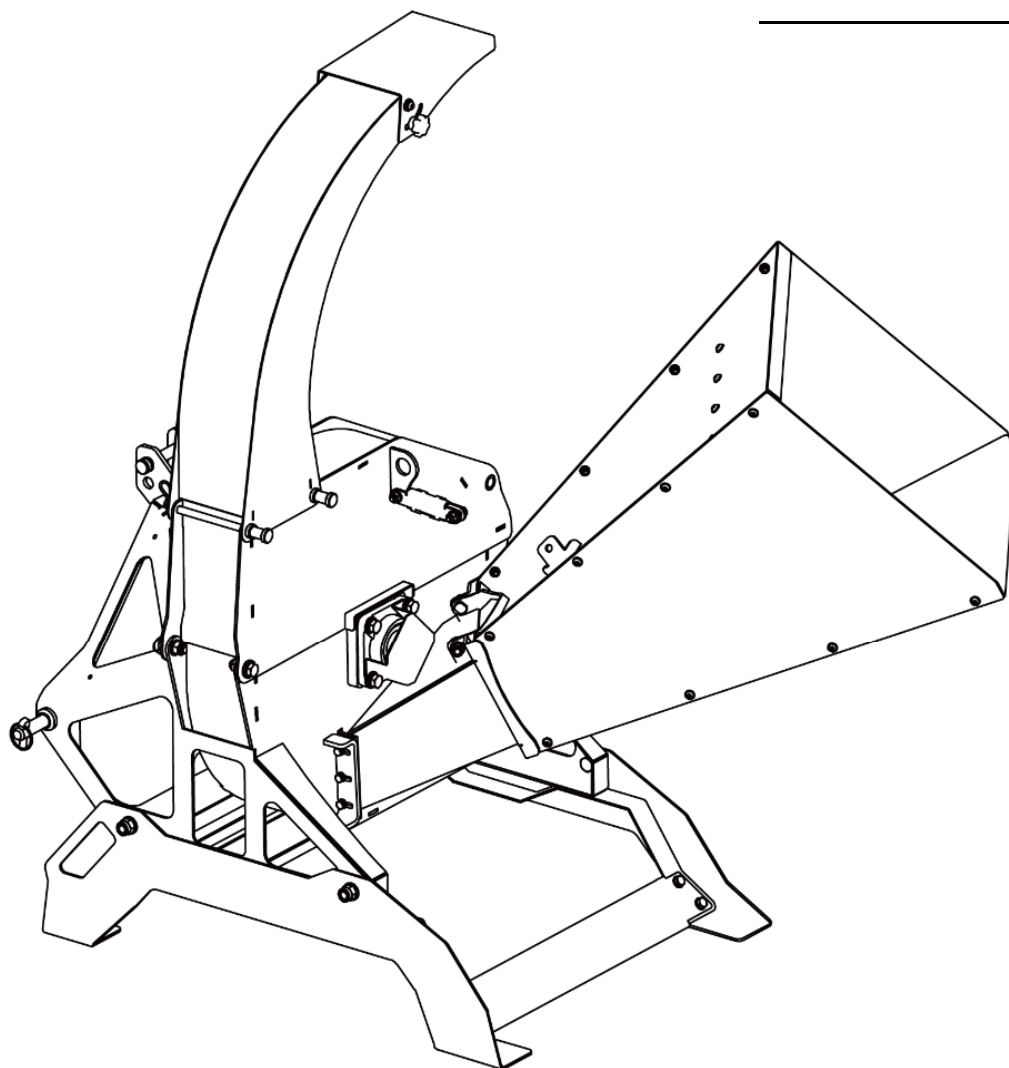

Wood Chipper

OPERATOR'S MANUAL

ME-WCAP50



Please carefully read this manual and follow all the instructions. Failure to comply with the warnings and precautions may result in serious injury or death.

V1.0 3250200975

Content

CONTENT	1
SAFETY PRECAUTIONS	5
Safety First	5
Safety Alert Symbol	6
Safety for Children.....	7
Operation Safety	7
Tractor Shutdown Safety	8
Use A Safety Chain.....	8
Transport Safely	9
Avoid Contact Blades	9
Stay OFF Discharge Chute.....	10
Hopper Safety	10
Maintenance Safety	10
Preparation before Maintenance.....	11
Personal Protective Equipment.....	12
Keep Riders off Machinery.....	12
Safety Lights and Devices	12
Seat Belt and ROPS	13
Hydraulic System Safety.....	13
Handle Chemicals Properly	13
Tire Maintenance Safety	14

Transport Safety	14
Storage Safety	14
Disposal Safety	15
Safety Labels	15
Labels Location.....	16
PRODUCT INTRODUCTION	17
Technical Data	19
Implement Identification	20
UNPACKING	20
ASSEMBLY & SET-UP	23
Discharge Chute Assembly	23
Feed Hopper Assembly	24
Tractor Shutdown	25
Tractor Hook-up	26
Driveline Installation	28
Driveline Length Check.....	29
Maximum Extended Position	30
Customize Driveline.....	30
Driveline Interference Check	31
OPERATION	32
Before Start-up	32
Opening and Closing Disc Housing	32
Adjusting Deflector Position.....	33

Adjusting Discharge Chute	34
Checklist before Operation	34
Operating the Machine	36
Starting the Machine	37
Feeding Materials	37
Stopping the Machine	37
SERVICE AND MAINTENANCE	38
General Service.....	38
Maintenance Schedule	38
PTO Shaft Maintenance	39
Tightening Torque.....	40
Replacing Blades	41
STORAGE AND TRANSPORT.....	42
Storage	42
Transport	42
TROUBLESHOOTING.....	43
EXPLODED VIEW AND PARTS LIST	44
WARRANTY.....	51

This page left blank intentionally!

SAFETY PRECAUTIONS

Listed below descriptions are common practices that may or may not be applicable to the products described in this manual.

Safety First

Careful operation is your best assurance against an accident.

Please be fully aware that you are responsible for the safe operation and maintenance of your implement. You must ensure that you and anyone else who is going to operate, maintain or work around the implement is familiar with the operating and maintenance procedures and related safe information contained in this manual. This manual is prepared to guide you through all essential operations related to this implement and alert you to all good safety practices that should be strictly followed.



Please constantly bear in mind that good safety practices not only protect you but also the people around you. Incorporate these practices an inseparable part into your safety program. Make sure that who operates this equipment is familiar with the recommended operating and maintenance procedures and follows all the safety precautions. Most accidents can be prevented. Do not risk injury of death by ignoring good safety practices.

- Thoroughly read and understand the “[Safety Labels](#)” section. Read all instructions noted on them.
- In order to provide a better view, certain photographs or illustrations in this manual may show an assembly with a safety shield removed. However, equipment should never be used in this condition. Keep all shields in place. If shield removal becomes necessary for repairs, replace the shield prior to use.
- Do not operate the equipment while under the influence of drugs or alcohol, as they impair your ability to safely and properly operate the equipment.
- Never allow more than one person to operate the wood chipper at one time. If two people are working together it will increase the chance of your workmate engaging the machine or causing you to fall into the machine.
- If you hand is ever near the chipping or feeding area serious injury can occur.
- Never place your hands or feet on or near the material while the machine is engaged or feeding.
- Never place your hands beyond the opening of the hopper while the machine is running.
- Never allow children, disabled, or untrained persons to operate the chipper.

- Do not operated the chipper near bystanders, public roads, or anywhere that the debris may travel far enough to injure another person.
- Never move the chipper while it is operating.
- Do not wear loose clothing, jewelry, or anything that can catch a branch that is feeding into the chipper.
- Hair must be tied above the shoulders. If the operator needs to leave the equipment for any reason, switch this equipment off before leaving.
- Shut off the tractor and allow the chipper to come to a complete stop before removing any debris.
- Never perform any maintenance or repair while the chipper is running.
- Do not use this equipment indoors, never use a stool, ladder to access the feed hopper if the machine is not switched off.
- Do not place any part of your body inside the guard.
- The operator should be familiar with all functions of the tractor/trailer and attached implement, and be able to handle emergencies quickly.
- Keep all bystanders away from equipment and work area. Never dismount from a moving tractor or leave tractor unattended with engine running.
- Do not allow anyone to stand between the implement and tractor while backing up to the implement.
- While transporting and operating equipment, watch out for objects overhead and along the sides such as fences, trees, buildings, wires, etc.
- Store implement in a safe and secure area where children normally do not play. When needed, secure implement against falling with support blocks.

Safety Alert Symbol

The SAFETY ALERT SYMBOL indicates there is a potential hazard to personal safety and extra precaution must be taken. When you see this symbol, be alert and carefully read the message that follows it. Hazard control, and accident prevention are dependent upon the awareness, concern, prudence, and proper training of personnel involved in the operation, transport, maintenance, and storage of equipment.

Be Aware of Signal Words

A signal word designates a degree or level of hazard seriousness. They are:

 **DANGER:** Indicates a hazardous situation that, if not avoided, will result in death or serious injury.

⚠ WARNING: Indicates a hazardous situation that, if not avoided, could result in death or serious injury.

⚠ CAUTION: Indicates a hazardous situation that, if not avoided, may result in minor or moderate injury.

Be Aware of Special Notices

Special notices are intended to point out important and helpful information that should be followed.

They are:

ATTENTION: Indicates that equipment or property damage could result if instructions are not followed.

NOTE: Indicates supplementary explanations that will be helpful when using the equipment.

Safety for Children

Tragedy can occur if the operator is not alert to the presence of children, Children generally are attracted to implements and their work.

- Never assume children will remain where you last saw them.
- Keep children out of the work area and under the watchful eye of a responsible adult.
- Be alert and shut the chipper down if children enter the work area.
- Never allow children to operate the machine, even under adult supervision.
- Never allow children to play on the chipper.

Operation Safety

- ALWAYS push the safety bar into the STOP position if a dangerous situation arises.
- ALWAYS keep body parts away from the hopper and wood chipper's other moving parts.
- ALWAYS feed the wood chipper with the thick end of the log first.
- ALWAYS feed the wood chipper so that the tree crown points away from the hopper.
- ALWAYS use a rod to push short pieces of tree into the rollers.
- ALWAYS push logs in from the rear of the log.
- ALWAYS stand at the side of the hopper when the wood chipper is chipping trees that have branches.
- NEVER feed the tree crown into the wood chipper first.
- NEVER feed the wood chipper with the thin end of the log first.
- NEVER exceed the wood chipper's nominal rpm.

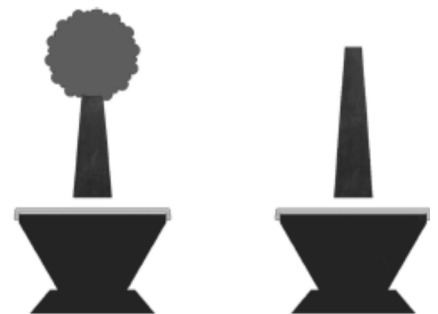

- NEVER attempt to remove any trapped material from between the feed rollers before the wood chipper has stopped and the roller console has been opened.
- Do not operate the wood chipper on uneven or sloping ground!
- NEVER start the wood chipper without the ejector spout fitted.



Tractor Shutdown Safety

If engaged, disengage power take-off. Park on solid, level ground and lower implement to ground or onto support blocks.

- Put tractor in park or set park brake.
- Turn off engine and remove ignition key to prevent unauthorized starting.
- Relieve all hydraulic pressure to auxiliary hydraulic lines.
- Wait for all components to stop before leaving operator's seat.
- Use steps, grab-handles and anti-slip surfaces when stepping on or off the tractor.
- If engaged, disengage power take-off.
- Park on solid, level ground and lower implement to ground or onto support blocks.
- Put tractor in park or set park brake.
- Turn off engine and remove ignition key to prevent unauthorized starting.
- Relieve all hydraulic pressure to auxiliary hydraulic lines.
- Wait for all components to stop before leaving operator's seat.
- Use steps, grab-handles and anti-slip surfaces when stepping on and off the tractor.

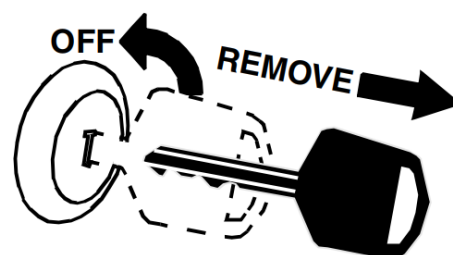

Use A Safety Chain

A safety chain will help control drawn machinery should it separate from the tractor drawbar.

Use a chain with the strength rating equal to or greater than the gross weight of the towed implement.

- Attach the chain to the tractor drawbar support or other specified anchor location. Allow only enough slack in the chain to permit turning.
- Always hitch the implement to the machine towing it. Do not use the safety chain to tow the implement.



Transport Safely

- When using the machine on public roads, observe the safety regulations for road places in force in the country where the machine is used.
- Avoid contact with any overhead utility lines or electrically charged conductors.
- Engage park brake when stopped on an incline.
- Maximum transport speed for an implement is 30 km/h. DO NOT EXCEED.
- Never travel at a speed which does not allow adequate control of steering and stopping. Some rough terrains require a slower speed. Sudden braking can cause a towed load to swerve and upset.
- Do not tow an implement that, when fully loaded, weights more than 1.5 times the weight of towing vehicle.
- ALWAYS keep the ejector spout within the width of the machine during transport. Remember to ensure that the ejector spout is securely fastened.
- NEVER use the wood chipper in enclosed or poorly ventilated spaces, because of the danger of carbon monoxide poisoning.
- NEVER start or operate the wood chipper before it has been fitted to the tractor's three-point linkage.
- NEVER start or operate the wood chipper if it does not stand on the ground.
- NEVER use the wood chipper with material that is not wood.
- NEVER use the wood chipper to push trees, stumps, etc.

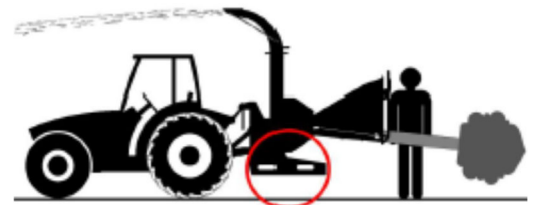
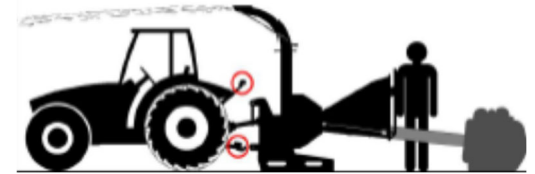
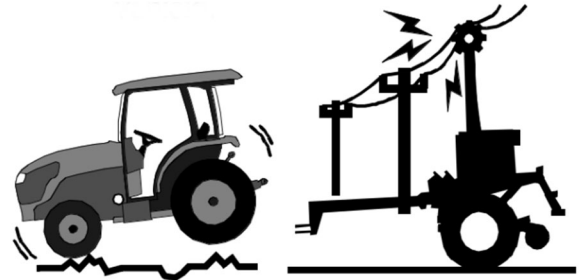

Avoid Contact Blades

Keep away from rotating blades to avoid death or serious injury from blade contact.

- Stay away and keep hands, feet and body away from rotating blades, drivelines and parts until all moving elements have stopped.
- Stop rotating blades disengage PTO and wait for blade to stop rotating before transport.

- If a material blockage occurs in the inlet or discharge areas of the chipper, shut down tractor engine, disengage the PTO and wait for all rotating motions to stop. Place the tractor in park position, engage the parking brake and remove the key before leaving the operator's seat. Clear the blockage before processing. Be sure to keep feet and hands clear of the blades.

Stay OFF Discharge Chute

Do not direct discharge duct towards people, animals or property. Always wear appropriate safety gear. Keep hands and feet out of discharge openings. The machine can expel wood chips fast enough to cause eye, cut, and impact injuries or property damage.

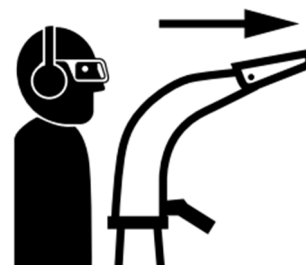

Hopper Safety

ALWAYS ensure that the hopper is free of people, animals and other foreign bodies before starting the wood chipper.

NEVER transport equipment in the hopper, such as forest chains, axes, chainsaws, etc.

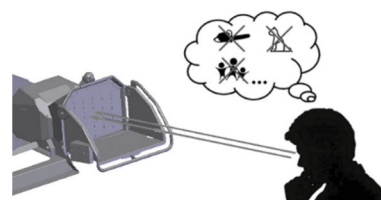

Maintenance Safety

- Good maintenance is your responsibility. Poor maintenance is an invitation to trouble.
- Follow good shop practices.
- Keep service area clean and dry.
- Be sure electrical outlets and tools are properly grounded.
- Use adequate light for the job at hand.
- Make sure there is plenty of ventilation. Never operate the engine of the tractor in a closed area. The exhaust gas may cause healthy problem.
- Before maintenance, shut off the tractor (See [Tractor Shutdown](#)).
- Allow equipment to cool before maintenance operation.
- Never work under the machine unless it is secured by a mechanical stand.
- Use personal protection devices such as safety goggles, hand gloves and hearing protectors, when performing any service or maintenance work. Use heavy gloves when handling blades.
- Only use original parts for service and maintenance.
- A fire extinguisher and first aid kit should be kept readily accessible while performing maintenance on this equipment.

- Periodically tighten all bolts, nuts and screws and check that all pins are properly installed to ensure unit is in a safe condition.
- Do not weld or torch on galvanized metal as it will release toxic fumes.
- Always make sure any material and waste products from the repair and maintenance of the implement are properly collected and disposed.
- Disconnect battery (If the implement has the battery) ground cable (-) before servicing or adjusting electrical systems or before welding on implement.
- Do not grease or oil implement while it is in operation.
- Do not work under any hydraulically supported equipment. It can settle, suddenly leak down, or be lowered accidentally. If it is necessary to work under the equipment, securely support it with stands or suitable blocking beforehand.
- When completing a maintenance or service function, make sure all safety shields and devices are installed before placing machine in service.
- During the engine start-up period, make sure that all parts of the machine are installed and that all safety devices of the machine are correctly fitted before using the machine.
- Do not put any material on the feeder until the engine has been started or the engine speed has reached its maximum speed.
- Do not use the machine for functions other than those for which it was designed.
- Do not put stones, metal, glass, plastic, soil into the wood chipper and do not remove any protective devices or any attachments while the machine is in operation.
- Do not reach into rotor or feed hopper openings when the engine is running. Install and secure access covers before starting engine.
- Keep the working area clean and free of debris to prevent tripping. Operate only on level ground.
- Do not point discharge at people, animals or buildings. Rotor can expel wood chips fast enough to cause Injury.
- Do not carry out service or repairs on the wood chipper while it is connected to the tractor.

Preparation before Maintenance

- Be prepared if a fire starts.
- Keep a first aid kit and fire extinguisher handy.
- Keep emergency numbers for ambulance, hospital and fire department near the working area.
- NEVER carry out service or repairs on the wood chipper while it is connected to the tractor.



Personal Protective Equipment

- Wear protective clothing and equipment appropriate for the job such as safety shoes, safety glasses, hard hat, dust mask, and ear plugs.
- Clothing should fit snug without fringes and pull strings to avoid entanglement with moving parts.
- Prolonged exposure to loud noise can cause hearing impairment or hearing loss. Wear suitable hearing protection such as earmuffs or earplugs.
- Operating a machine safely requires the operator's full attention. Avoid wearing headphones while operating equipment.
- Good maintenance is your responsibility. Poor maintenance is an invitation to trouble.
- Follow good shop practices.
 - Keep service area clean and dry.
 - Be sure electrical outlets and tools are properly grounded.
 - Use adequate light for the job at hand.
- Make sure there is plenty of ventilation. Never operate the engine of the towing vehicle in a closed building. The exhaust fumes may cause asphyxiation.
- Before working on this machine, shut off the engine, set the brake, and turn fuel valve off.
- Never work under equipment unless it is blocked securely.



Keep Riders off Machinery

- Never carry riders on the tractor or implement.
- Riders obstruct operator's view and interfere with the control of the power machine.
- Riders can be struck by objects or thrown from the equipment.
- Never use the tractor or implement to lift or transport riders.



Safety Lights and Devices

- A slow moving power machine can create a hazard when driven on public roads. They are difficult to see, especially at night.
- Flashing warning lights and turn signals are recommended whenever driving on public roads.
- For tractors and other agriculture equipment, a Slow Moving Vehicle (SMV) sign is required when traveling on public roads.

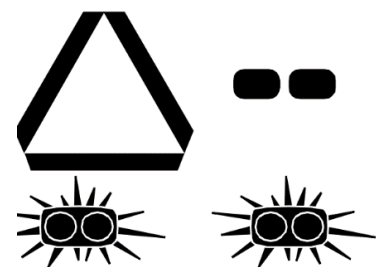

Seat Belt and ROPS

- We recommends the use of a CAB or roll-over-protective structures (ROPS) and seat belt in almost all power machines. Combination of a CAB or ROPS and seat belt will reduce the risk of serious injury or death if the power machine should be upset.
- If ROPS is in the locked-up position, fasten seat belt snugly and securely to help protect against serious injury or death from falling and machine overturn.



Hydraulic System Safety

- Make sure that all the components in the hydraulic system are kept in good condition and are clean.
- Before applying pressure to the system, make sure all components are tight, and that lines, hoses and couplings are not damaged.
- Do not attempt any makeshift repairs to the hydraulic lines, fittings or hoses by using tapes, clamps or cements. The hydraulic system operates under extremely high pressure. Such repairs will fail suddenly and create a hazardous and unsafe condition.
- Wear proper hand and eye protection when searching for a high pressure hydraulic leak. Use a piece of wood or cardboard as a backstop instead of hands to isolate and identify a leak.
- If injured by a concentrated high-pressure stream of hydraulic fluid, seek medical attention immediately. Serious infection or toxic reaction can develop from hydraulic fluid piercing the skin surface.
- Relieve pressure on hydraulic system before maintaining or working on system.



Handle Chemicals Properly

- Protective clothing should be worn.
- Handle all chemicals with care.
- Follow instructions on container label.
- Agricultural chemicals can be dangerous. Improper use can seriously injure persons, animals, plants, soil, and property.
- Inhaling smoke from any type of chemical fire can be a serious health hazard.
- Store or dispose of unused chemicals as specified by the chemical manufacturer.



Tire Maintenance Safety

- Tire changing can be dangerous and must be performed by trained personnel using the correct tools and equipment.
- Always properly match the wheel size to the properly sized tire.
- Always maintain correct tire pressure. Do not inflate tires above recommended pressures shown in the Operator's Manual.
- When inflating tires, use a clip-on chuck and extension hose long enough to allow you to stand to one side and NOT in front of or over the tire assembly. Use a safety cage if available.
- Securely support the implement when changing a wheel.
- When removing and installing wheels, use wheel handling equipment adequate for the weight involved.
- Make sure wheel bolts have been tightened to the specified torque.



Transport Safety

- Comply with state and local laws governing safety and transporting of machinery on public roads.
- Check that all the lights, reflectors and other lighting requirements are installed and in good working condition.
- Do not exceed a safe travel speed. Slow down for rough terrain and cornering.
- Fold up and secure feed hopper before moving or transporting.
- Be sure the machine is hitched positively to the tractor and a retainer is used through the mounting pins.
- Do not drink and drive.
- Be a safe and courteous driver. Always yield to oncoming traffic in all situations, including narrow bridges, intersections, etc. Watch for traffic when operating near or crossing road-ways.
- Never allow riders on the machine.

Storage Safety

1. Store the machine in an area away from human activity. Do keep the machine out of the children's reach. Do not permit children to play on or around the stored machine.
2. Store the machine in a dry, level area.



3. Clean grease and oil as required and protect it from the elements.
4. ALWAYS park the wood chipper on a level surface.
5. NEVER park the wood chipper on inclined or uneven surfaces.

Disposal Safety

1. Improper disposal of oil or other waste may be hazardous to the environment.
2. When oil is emptied from the machine, it must be poured into a leak-proof container suitable for oil. It is not permissible to store oil in a container used for food or drink, in order to avoid the oil being consumed by mistake and causing serious injury. It is prohibited to spill oil on the ground, or pour it into a drain or anywhere leading to a water source.
3. Discarded oil, fuel, coolant, brake fluid, filters and batteries may not be thrown away or emptied in just any way. Contact your local authority for further information.

Safety Labels

Your implement comes equipped with all safety labels in place. They were designed to help you safely operate your implement. Read and follow their directions.

1. Keep all safety labels clean and legible.
2. Replace all damaged or missing labels.
3. When ordering new components make sure the correct safety labels are included in the request.
4. Refer to steps below for proper label placement.
 - a) Clean surface area where label is to be placed.
 - b) Spray soapy water onto the cleaned area.
 - c) Peel backing from label and press label firmly onto the surface.
 - d) Squeeze out air bubbles with edge of a card or with a similar type of straight edge.

Labels Location

Label locations below are common practices of ME-WCAP50 machine that may or may not be applicable to the products described in this manual.

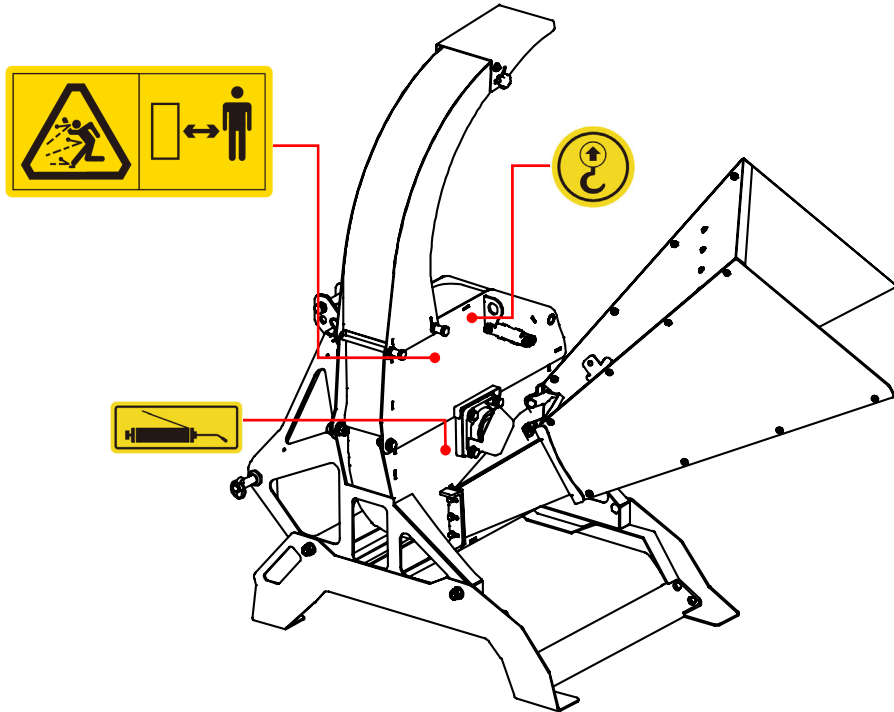

Figure 1-1

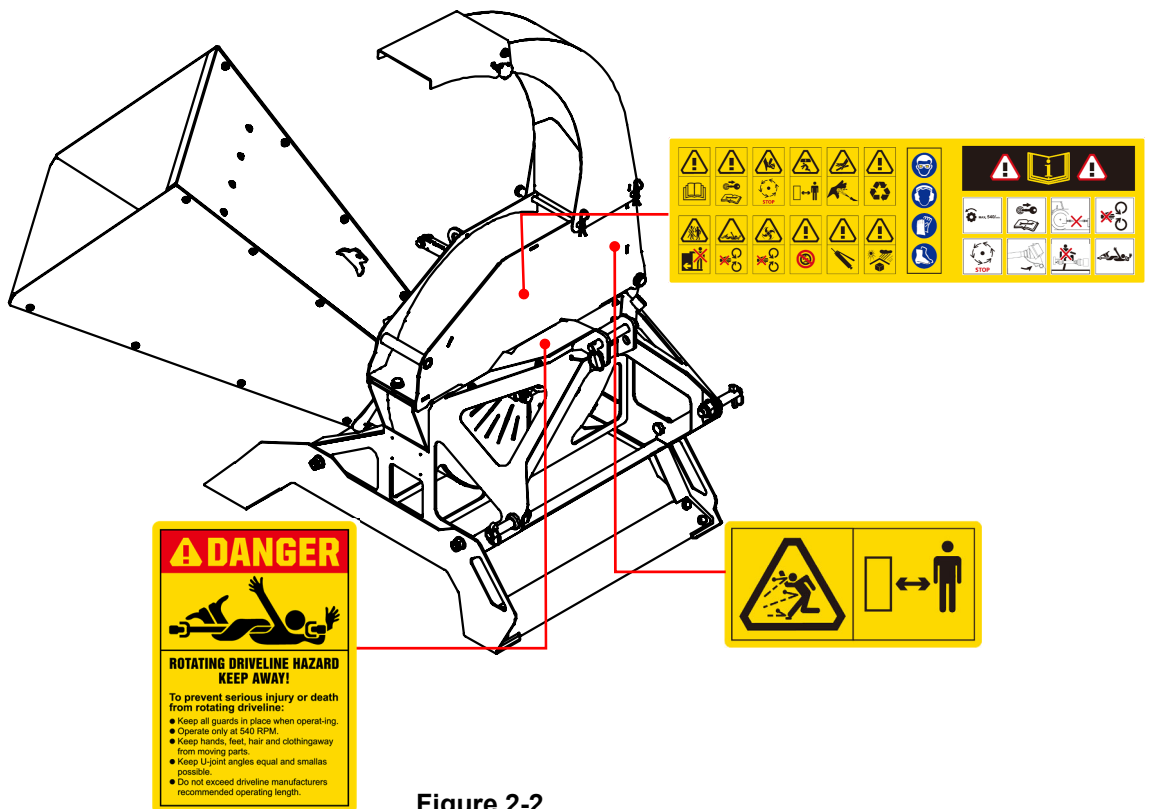

Figure 2-2

PRODUCT INTRODUCTION

Listed production introduction is common chipper of ME-WCAP50 that may or may not be applicable to your wood chipper. If you have any problem not covered in the manual, please contact us freely for technical supporting.

The wood chipper is the perfect tool to help clear your land of fallen limbs and branches. Wood chippers are designed to chip and chop scrap lumber, small trees, brush, limbs and other wood material. The machine must not be used for materials containing stone, metal or other foreign bodies. These foreign bodies can in the best case dull the knives and in the worst case break the machine. Knives and anvil can break when stone or metal comes in between them. The machine must not be used for wood chipping of wood containing nails, screws, arming etc. When feeding branches you must stand next to the feeding hopper. The branches can be thrown around when the retract rollers get a hold of them. Logs must be fed into the machine from the back.

Wood chipper applications:

The knives of wood chipper are made from very high quality tool steel. That being said, all chipper knives will dull over time and will require sharpening or replacing at some point. If the knives are treated with the same respect as other implements, such as chainsaw chain, the longest life out of them will be got. Follow the guidelines below to get the most out of your chipper knives.

All chippers will be performed better when chipping fresh, green, clean limbs. The moisture in the limbs lubricates the knives and reduces friction. (Do not however attempt to chip rotten wood since it will plug your chipper)



Although the dry material can be chipped, this will wear the knives at a faster rate than fresh green material. User should must use your best judgment on this type of material. Try to avoid dirty limbs, since the dirt is abrasive and will reduce knives life expectancy.



Always avoid material that may contain nails or foreign objects.



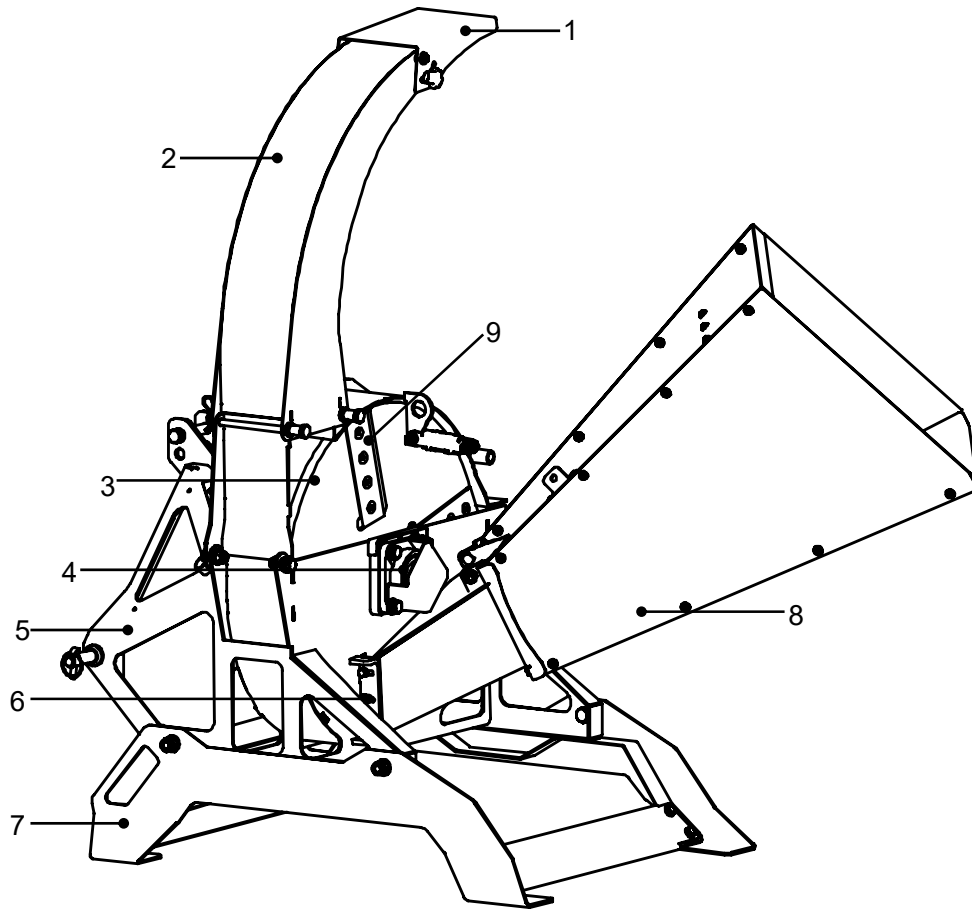

Figure 2

Main parts name list:

Item	Part Name	Item	Part Name
1	Deflector	6	Counter-knife
2	Discharge chute	7	Feet component
3	Knife disc	8	Feed hopper
4	Rotor component	9	Blade(knife)
5	Hitch assembly		

Technical Data

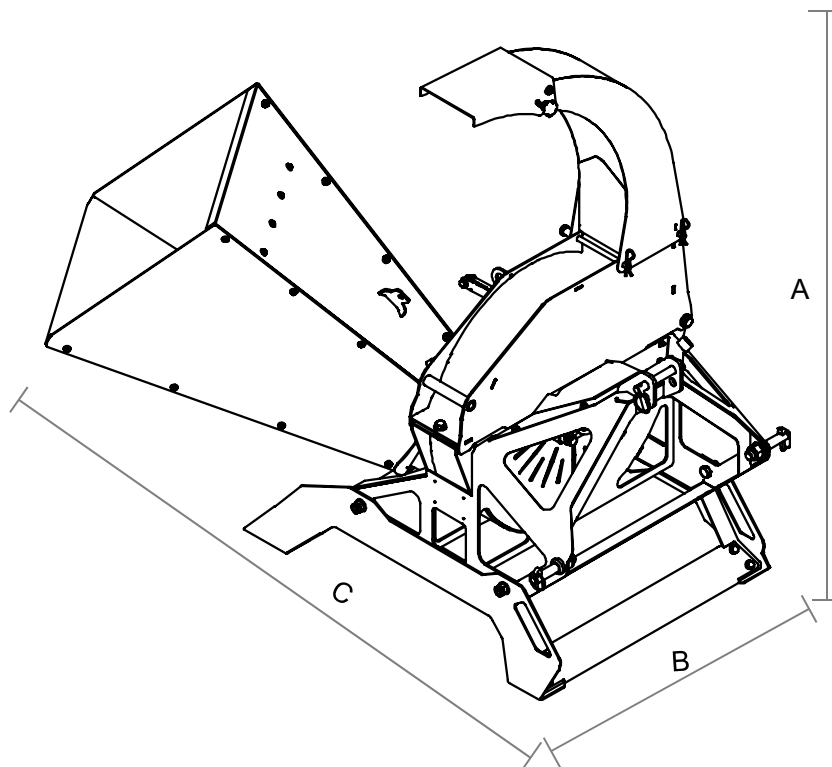

Figure 3

Implement specification table:

Model		ME-WCAP50
Dimension	A	1500 mm (59")
	B	1320 mm (52")
	C	1510 mm (59")
Chipping Capacity		130 mm (5")
Chipper Type		Disc
Feed System		Gravity
Engine HP Range		15-50 HP (11-37 KW)
Chipper Hopper Opening		500x618 mm (20" x 24")
Chipper Housing Opening		130x232 mm (5" x 9")
Quantity of Rotor Knives		4 pcs
Knife Disc Diameter		630 mm(25")
Knife Disc Thickness		19 mm (3/4")
Discharge Chute Height		1590 mm (63")

Model	ME-WCAP50
Discharge Chute Rotation	0°/180°
Drive System	PTO Direct Drive
Rated RPM	540-1000
PTO Height	460-560 mm (18"-22")
Mounting System	CAT I / ASABE QUICK HITCH I
Weight	187 kgs (412 lbs)

Implement Identification

The identification nameplate is affixed to the frame of each implement. It contains: the Manufacturer, Type, Serial Number, Model Number, Weight. The nameplate (Shown in the below) is for reference only and is based on the real thing.



TYPE <input style="width: 80%;" type="text"/> TYPE <input style="width: 80%;" type="text"/>	YEAR <input style="width: 80%;" type="text"/> ANNÉE <input style="width: 80%;" type="text"/>
SERIAL NO. <input style="width: 80%;" type="text"/> N° DE SÉRIE <input style="width: 80%;" type="text"/>	WEIGHT <input style="width: 80%;" type="text"/> POIDS <input style="width: 80%;" type="text"/>

Toll Free: 1-866-718-4746
info@mateng.ca www.mateng.ca

UNPACKING

After unpacking, please check the components shown in **Figure 4**.

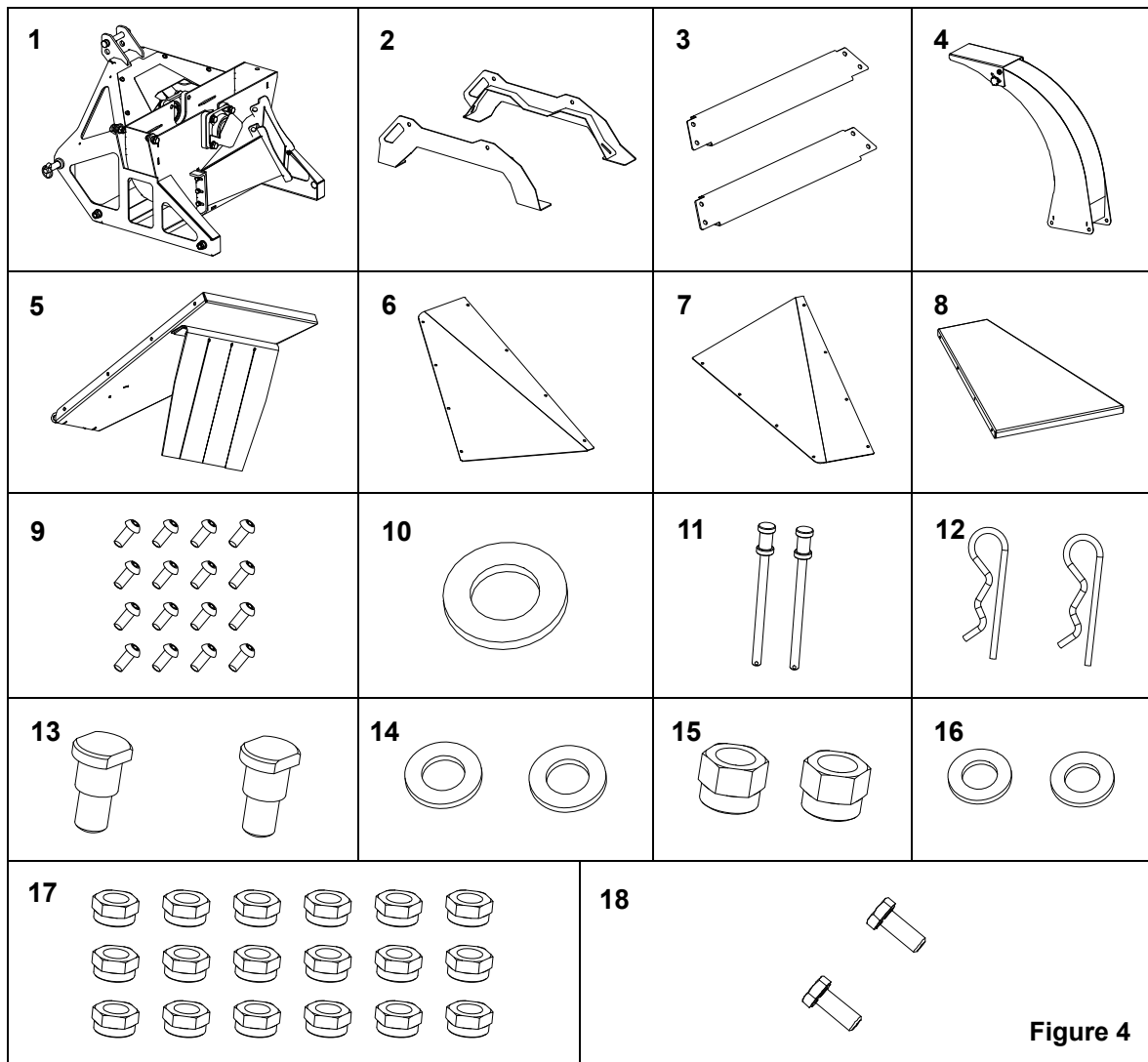

Figure 4

Unpacking parts description list:

Item	Specification	Description	Qty.	Packing
1	/	Host	1pcs	Single pack
2	W01019A01400-000	Right foot	1pcs	Single pack
	W01019A01200-000	Left foot	1pcs	Single pack
3	W01019A01000-005	Connection plate	2 pcs	Single pack
4	/	Discharge chute	1 pcs	Single pack
5	W01020A03100-000+ W01020A03000-006+ W01020A03000-007	Top plate component (protection curtain+ pressing plate)	1+1+1 pcs	Single pack

Item	Specification	Description	Qty.	Packing
6	W01017A06000-001	Left plate	1 pcs	Single pack
7	W01017A06000-005	Right plate	1 pcs	Single pack
8	W01017A06000-004	Bottom plate	1 pcs	Single pack
9	GB/T70.2-M8×20-8.8-EP•Zn	Hex. head screw	16 pcs	Bale
10	GB/T95-8-EP•Zn	Flat washer	32 pcs	Bale
11	W01020A06000-004	Location shaft	2 pcs	Bale
12	Din11024-4-EP•Zn	R Pin	2 pcs	Bale
13	W01019A03000-002	Location pin	2 pcs	Bale
14	GB/T95-12-EP•Zn	Flat washer	2 pcs	Bale
	GB/T95-16-EP•Zn		4pcs	Bale
	GB/T95-10-EP•Zn		4pcs	Bale
15	GB/T889.1-M12-8-EP•Zn	Hex. lock nut	2 pcs	Bale
	GB/T889.1-M16-8-EP•Zn		4pcs	Bale
	GB/T889.1-M10-8-EP•Zn		8pcs	Bale
16	GB/T95-8-EP•Zn	Flat washer	2 pcs	Bale
17	GB/T889.1-M8-8-EP•Zn	Hex. lock nut	18 pcs	Bale
18	GB/T5873-M10X25-8.8-EP•Zn	Hex. bolt	8 pcs	Bale

Tools for installation process list:

No.	Description	Specification	Conditions of Use	Qty.
1	Open end wrench	/	M8/M12 bolt fastening	2
2	Hex. key	/	M8/M12 bolt fastening	1
3	Hammer	/	/	1
4	Torque wrench	10-220N.m	Measuring torque	1
5	Wind gun	1280t	Match the corresponding sleeve instead of the wrench to tighten the bolt	1

ASSEMBLY & SET-UP

Column Feet Assembly

The feet should be installed firstly. The column feet consist of two (2) feet which has two connection plates that require bolting together.

To assemble column feet:

1. Locate the right foot (2) and insert it into right side of host (0), as shown below.
 2. Repeat the step 1 to hinge the left foot (1).
 3. With the right and left feet bolted to the hinge, the two feet can be tightened to the outside of it using eight (8) hex. nuts (4) with flat washers (3).
 4. Install the two connection plates (3&0) using hex. bolt (1), flat washer(2), tighten it using hex. locking nut (5) with flat washer (4).
- The bolt with flat washer should be installed in the outside of connection plates, see figure below.

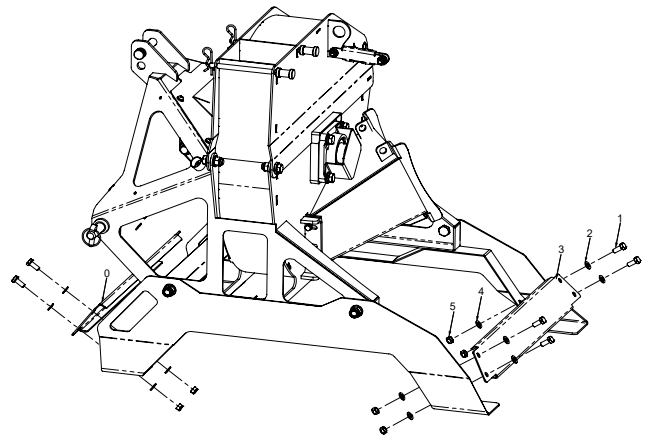
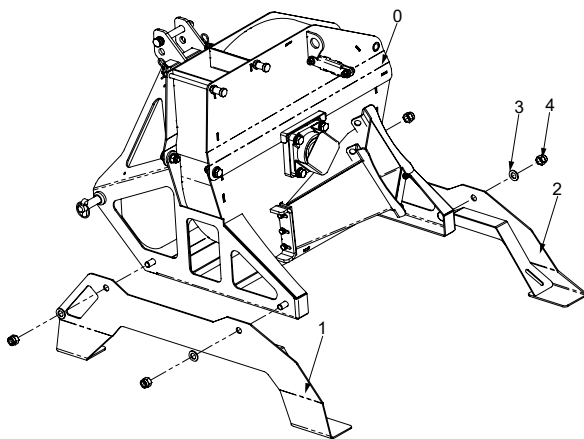

Discharge Chute Assembly

The discharge chute comes pre-assembled from the factory. Using the hardware listed **UNPACKING**, fasten the discharge chute assembly to the host. There are two positions can be installed, home position is recommended, see figure below.

To assemble discharge chute:

1. Locate and insert the two location shafts (1) into host, as shown below.
2. Lock it via two R Pins (2).

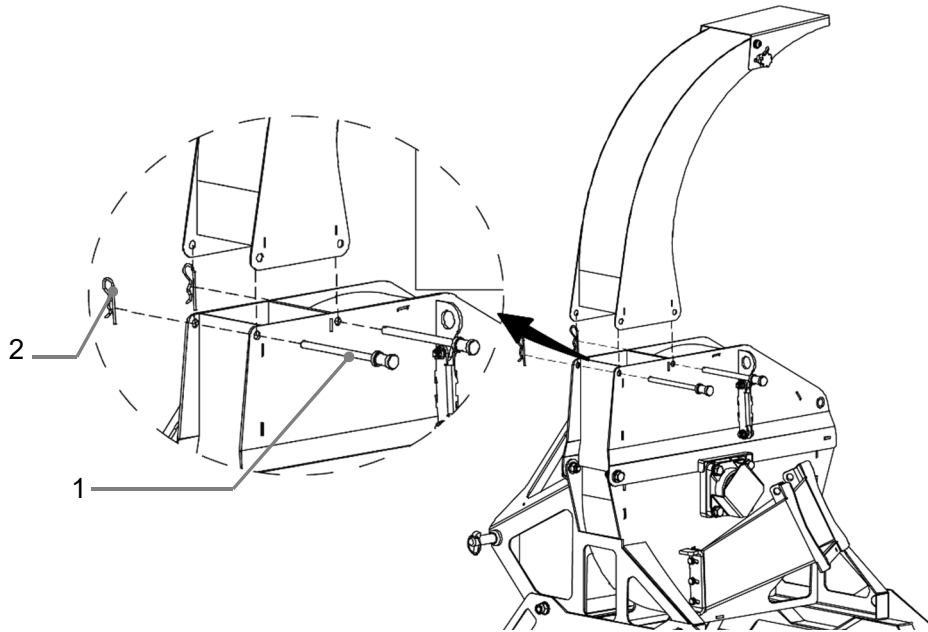
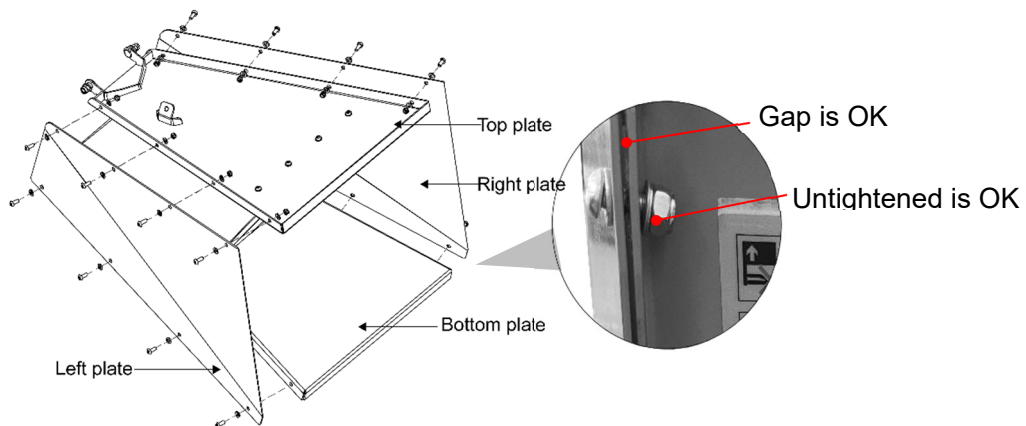

Figure 5

Feed Hopper Assembly

1. Install the feed hopper and do not fully tighten any panel fasteners at this time (see picture below), make sure there is a gap between the plates for easy adjustment during the installation process.



2. Pre-tighten top four nuts (see circles below) of feed hopper and ensure there is a litter gap to adjust connection mouth, other nuts should be keep loosen.

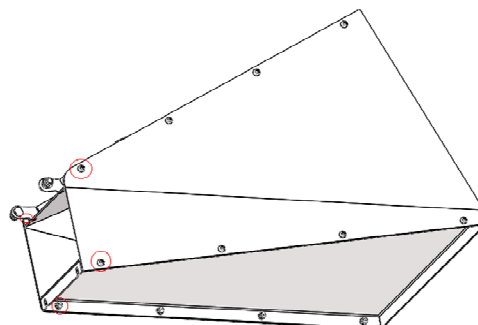

3. Lift the feed hopper, align the two top threaded holes installed on the top plate of feed

hopper via two location pins (1), flat washers(2)& lock nuts(3), then pre-tighten them (see picture below).

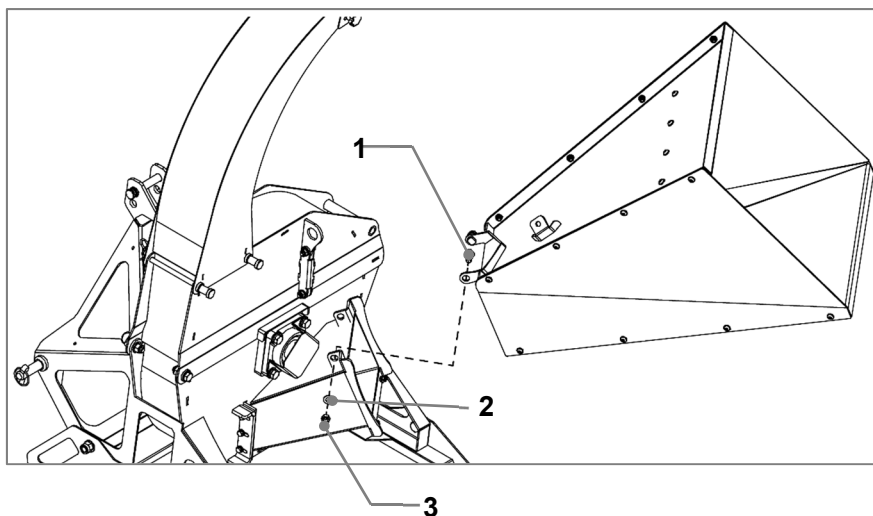

4. Rotate the feed hopper upwards or downwards, and there is no jamming.
5. Match the groove (1) of feed hopper to hex. head screw (4) after pre-tighten the M8 screw(4) with flat washer(3) and nut (2).

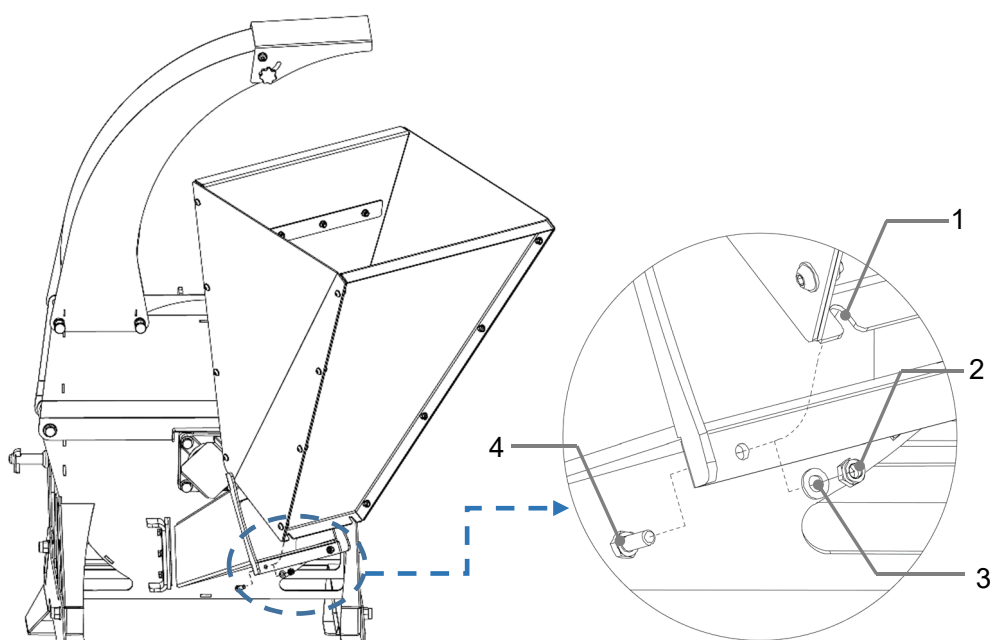

6. Tighten all nuts.

Note: If you have any problem during operation, please contact us for technical supporting freely!

Tractor Shutdown

The following are basic tractor shutdown procedures. Follow these procedures and any additional shutdown procedures provided in your tractor Operator's Manual before leaving the operator's seat.

1. Reduce engine speed and disengage power take-off if engaged.
2. Park tractor and implement on level, solid ground.
3. Lower implement to ground or onto non-concrete support blocks.

NOTE: Due to the over running clutch, the rotor blades will continue to spin after the driveline stops.

4. Put tractor in park or set park brake, turn off engine, and remove switch key to prevent unauthorized starting.
5. Relieve all hydraulic pressure to auxiliary hydraulic lines.
6. Wait for all components to come to a complete stop before leaving the operator's seat.
7. Use steps, grab-handles and anti-slip surfaces when stepping on or off the tractor.

Tractor Hook-up

WARNING

- A crushing hazard exists while hooking-up and unhooking the implement. Keep people and animals away while approaching the implement or pulling away from the implement. Do not operate hydraulic controls while a person or an animal is nearby.
- Always follow "[Tractor Shutdown](#)" to power off.
- Tractor horsepower and hitch category should be within the required range. The lower 3-point arms must be stabilized to prevent side-to-side movement.

Note:

- This chipper is featured with a hitch design. It can be attached to the front of a tractor, some chippers can be attached to both the front and rear of a tractor. Attaching a chipper to the front of a tractor typically follows a similar process to attaching it to the rear, although there may be some differences based on the specific tractor. Make sure the chipper is compatible with your tractor's front-end attachment system.
- There are one pair of extra hitch pins delivered at your disposal.
- The draw bar should be checked for clearance when the chipper is attached for the first time. Move drawbar ahead or remove if it interferes.

To connect tractor to implement by quick hitch:

1. Install the quick hitch to the 3-points arms of tractor before perform the connection.
2. Put a bushing located on the blade packing into top link pin.
3. Repeat step 2 to install the other two bushings into the left and right lower link pins.
4. Level the implement to the ground. If need, adjust it.
5. Go ahead and fire up the tractor.

- Back up the tractor and hook it up to the implement.

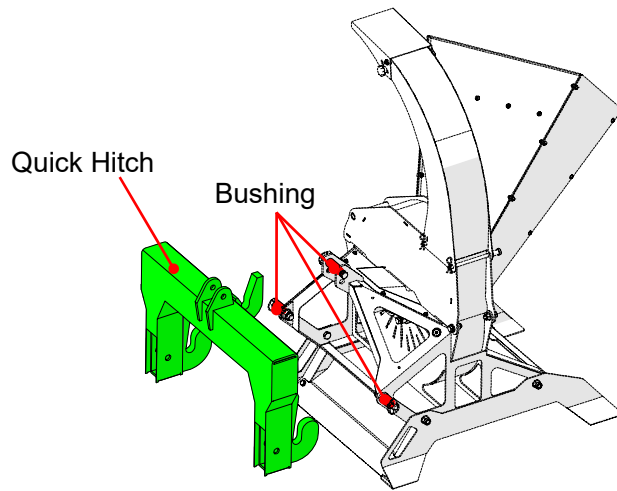

Figure 6-1

To hitch to tractor:

- Remove Pin (#6), Hanging on the pin (#5), locknuts (#4), pins (#2), plain washers (#3) and hitch pins (#1).
- Adjust the top link of the three-point hitch system on the tractor to match the height of the top link attachment point on the chipper. This helps ensure that the chipper is level when attached;
- Attach tractor's top center link and secure with pins accordingly:

Attach tractor to the chipper:

Upper Hook-Up:

- Attach lower 3-point arms to the upper center hitch clevises with hitch pins (#6) and secure with Hanging on the pin (#5).

Lower Hook-Up:

- Attach center 3-point link to the lower hitch clevis with pins (#2) and secure with Locknuts (#4), Plain washers (#3) and hitch pins(#1)

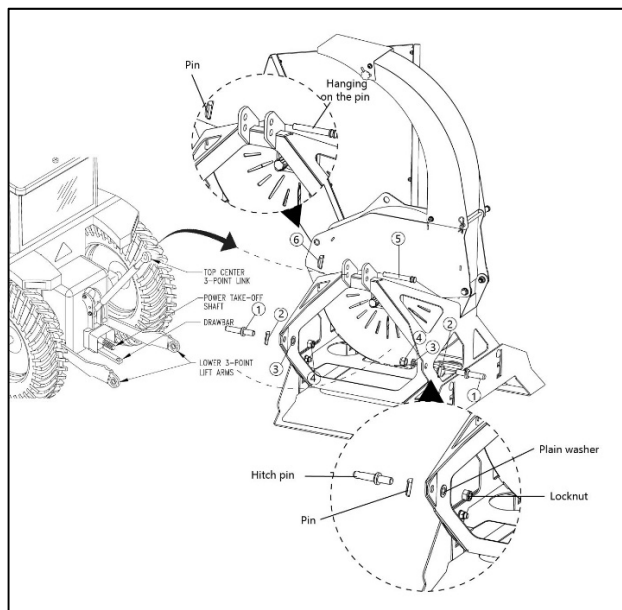

Figure 6-2

Driveline Installation

Listed below are common practices that may or may not be applicable to the products described in this manual.

Note: There are 3 types of PTO shafts available.

DANGER

- Do not engage tractor PTO while hooking-up and unhooking the prop shaft or stand near a rotating prop shaft. A person's body and/or clothing may get entangled to cause severe injury.
- Do not use a power take-off adapter. The adapter will increase strain on the tractor's power take-off shaft causing possible damage to shaft and driveline. It will also defeat the purpose of the tractor's power take-off shield.
- Make certain driveline yokes are securely fastened at each end. A loose yoke can work free allowing the driveline to rotate uncontrollably.

Type A shaft has interchangeable ends for installation;

Type B shaft shall have the end where safety pin locates connected with the implement;

Type C shaft shall have end where the clutch locates connected with the implement.

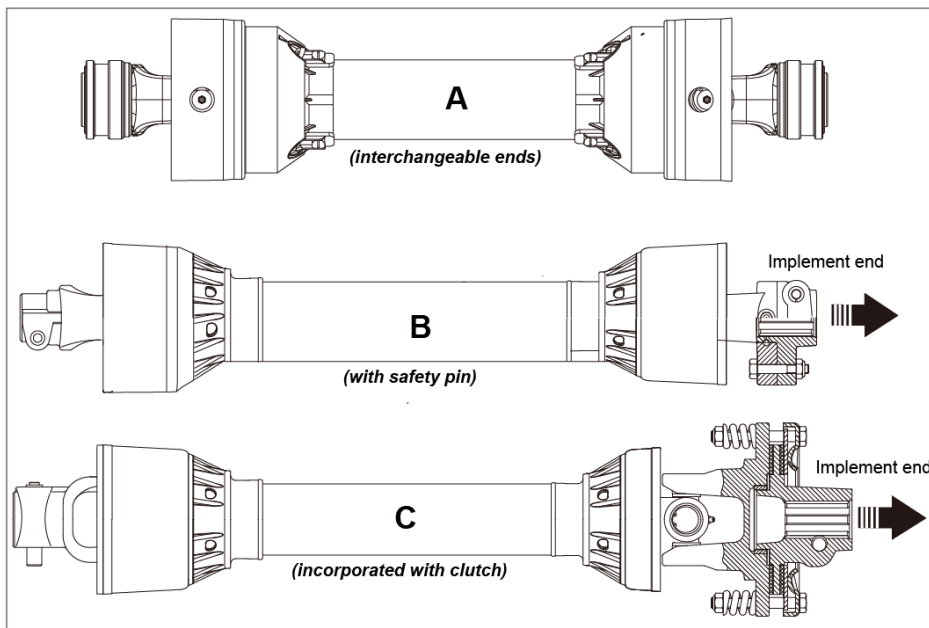

Figure 7

1. Park tractor on a level surface. Slowly engage tractor 3-Point lift lever to raise implements until gearbox shaft is in line (level) with tractor PTO shaft.
2. Place gear selector in park, set park brake, shut tractor off, and remove switch key.
3. Slide inner yoke (implement end) of driveline onto the gearbox. Secure driveline with yoke locking device.

4. Slide outer yoke of driveline over the tractor PTO shaft. Secure driveline with yoke locking device
5. If the driveline is too long and does not fit between tractor and gearbox, skip to [Customize Driveline](#) to shorten the driveline.
6. The driveline should now be moved back and forth to ensure secured connection at both ends. Reattach any end that is loose. Go to [Driveline Length Check](#) to ensure proper accommodation.
7. Hook driveline safety chain on the tractor end of driveline to the tractor. Re-latch safety chain to the driveline shield.
8. Hook driveline safety chain on the chippers end of driveline to the chippers frame. Re-latch safety chain to the driveline shield.

Driveline Length Check

The PTO shaft that came with your machine may need to be shortened. A longer shaft is supplied because tractor lift arms vary in length. The PTO shaft must be free to telescope and not bottom out when going through its working range. It should never completely collapse in use. There should always be 2" (50mm) of space for retract. If the shaft bottoms out, the bearings on both ends can be overloaded and could fail causing damage or injury.

Hold inner and outer drivelines parallel to each other as shown and measure distance **L1**:

1. If **L1** is less than 1" (2.5 cm), skip to [Customize Driveline](#) to shorten the driveline.
2. If **L1** is greater than or equal to 1" (2.5 cm), skip to [Maximum Extended Position](#) below.

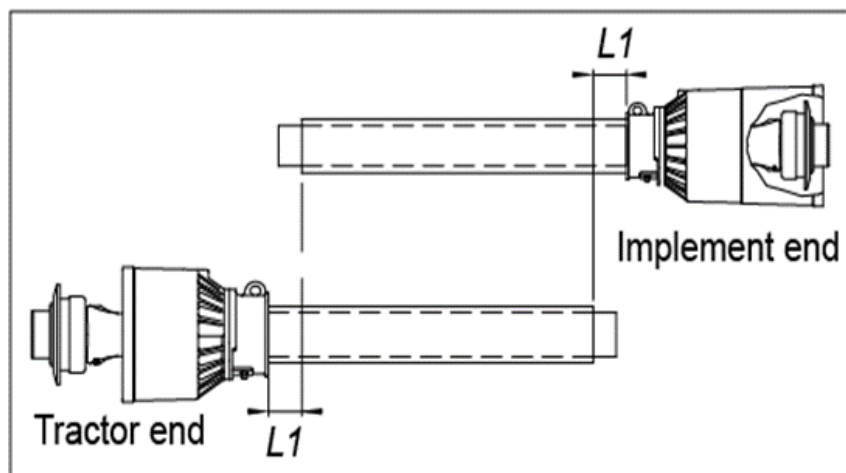

Figure 8

Maximum Extended Position

The driveline maximum allowable length must, when fully extended, have a minimum overlap (**L2**) of profile tubes by not less than 1/3 the free length with both inner and outer profile tubes being of equal length.

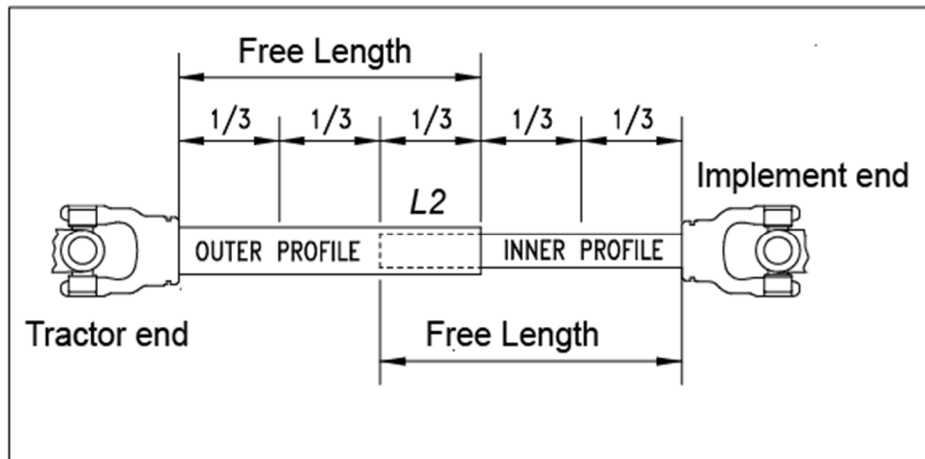

Figure 9

Customize Driveline

1. Un-hook driveline from tractor PTO shaft and pull outer and inner drivelines apart.
2. Re-attach outer driveline to tractor PTO shaft. Pull on inner and outer drivelines to be sure universal joints are properly secured.
3. Hold inner and outer drivelines parallel to each other:
 - a. Measure 1" (2.5 cm) ("**L1**" dimension) back from outer driveline universal joint shield and make a mark at this location on the inner driveline shield.
 - b. Measure 1"(2.5 cm) ("**L1**" dimension) back from the inner driveline universal joint shield and make a mark at this location on the outer driveline shield.
4. Remove driveline from tractor and gearbox shafts.
5. Measure from end of inner shield to scribed mark ("X" dimension). Cut off inner shield at the mark. Cut same amount off the inner shaft ("X1" dimension).
6. Measure from end of outer shield to scribed mark ("Y" dimension). Cut off outer shield at the mark. Cut same amount off the outer shaft ("Y1" dimension).
7. Remove all burrs and cuttings.
8. Apply multi-purpose grease to the inside of the outer shaft and reassemble the driveline.

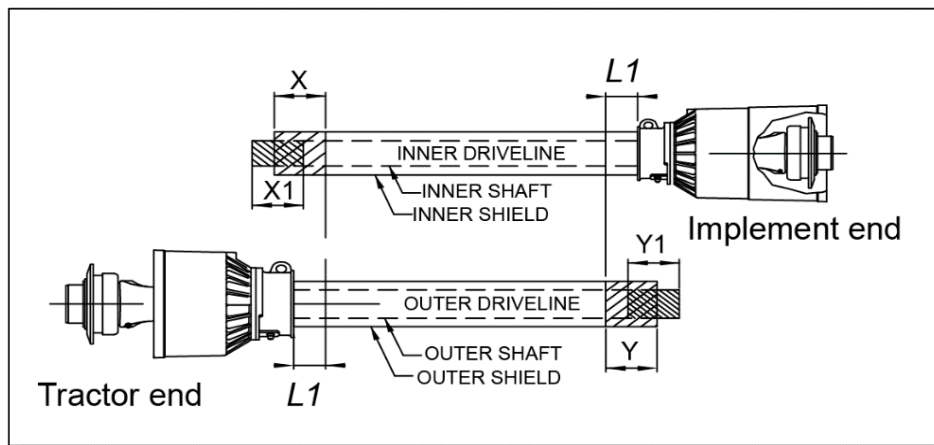

Figure 10

Driveline Interference Check

Lowly engage tractor 3-Point control lever to lower Implements while checking for sufficient tongue clearance. Move tongue ahead, aside, or remove if required.

1. Raise and lower implement to find maximum extended driveline length. Check to make certain the driveline does not exceed the maximum allowable length and 25° up or down.
2. If needed, set tractor 3-Point lift height to keep driveline from exceeding the maximum allowable length and 25° up or down.

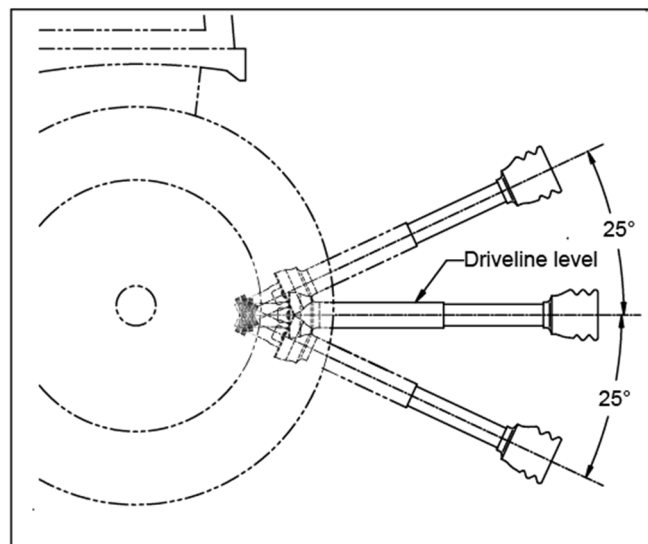

Figure 11

Note: If you have any problem, please contact us for technical supporting!

OPERATION

Before Start-up

Opening and Closing Disc Housing

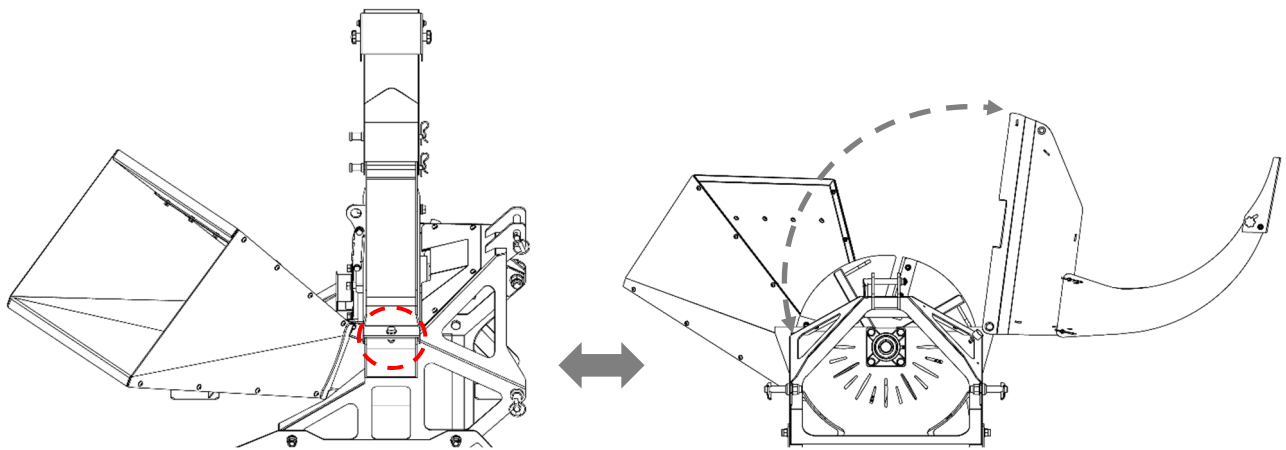

Figure 12

The wood chipper must be disconnected from the tractor's PTO when the disc housing is opened and may only be re-connected after the disc housing has been closed again!

To open the disc housing:

1. Ensure that the tractor's PTO has been disconnected.
2. Ensure that the disc is at a complete standstill.
3. Loosen the nut and remove the bolt, which secure the disc housing top and bottom parts together.
4. Open the top part of disc housing until it meets the stop.
5. The disc is now opened and secured from falling down.

Note: Keep fingers away from the knives when the disc is being turned.

To close the disc housing:

1. Turn the disc a few times to make sure that there are no objects in the disc housing. Exercise caution. Keep fingers away from the knives when the disc is being turned.
2. Close the top part of the disc housing.
3. Insert the hex. bolt and tighten it to secure together the top and bottom parts of the disc housing.

Adjusting Deflector Position

Each discharge hood is equipped with a deflector on the end to place the chips exactly where desired.

a. Manual Clamp:

The deflector is held in place by clamping nuts on each side.

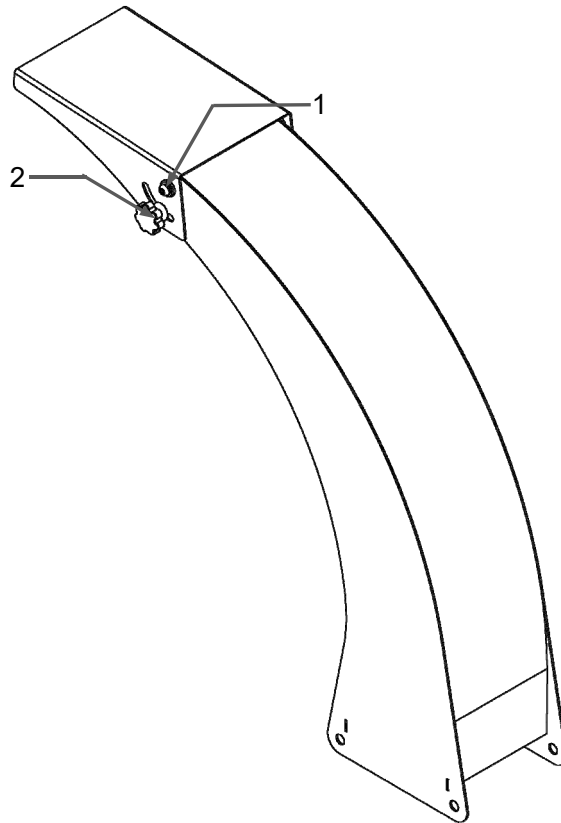

Figure 13

To adjust deflector position:

1. Loosen the nuts (2).
2. Move the deflector (1).
3. Tighten the nuts when the position is desired.

Adjusting Discharge Chute

The discharge chute should be assembled before perform adjusting procedures. The chute is free to rotate to 180 degrees or 0 degree.

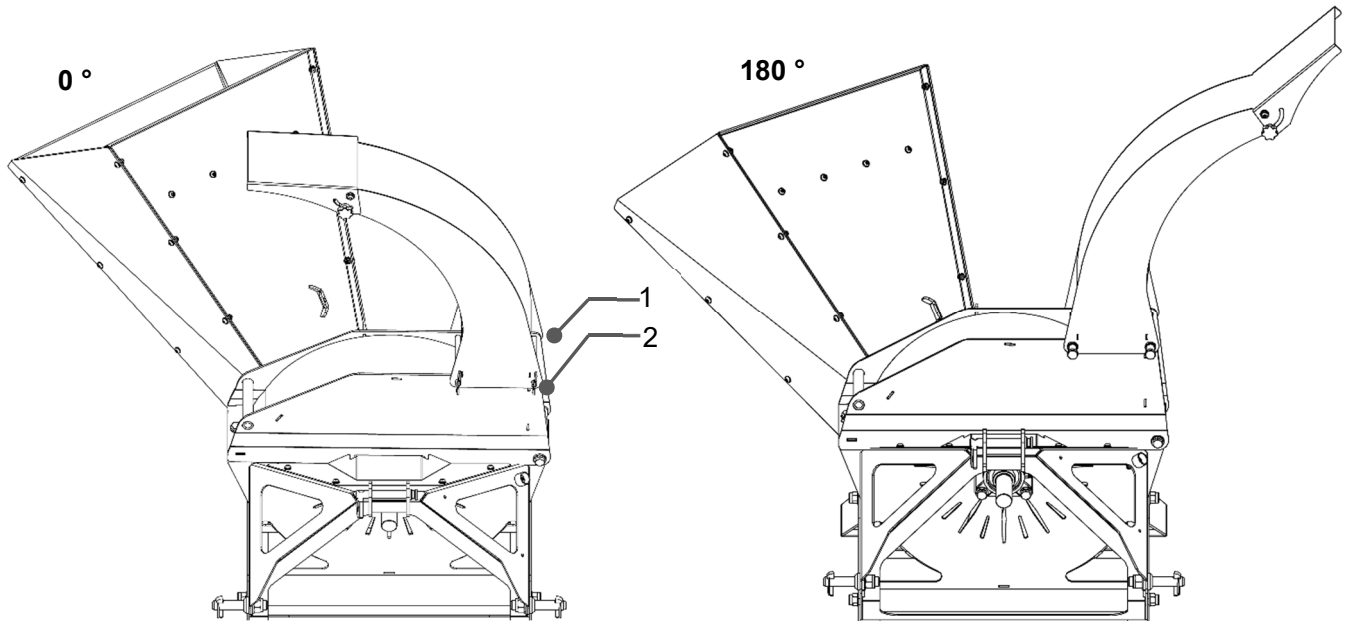

Figure 14

To adjust discharge chute:

1. Remove two R pins (2).
2. Slowly slide the locking shafts (1) and set aside.
3. Turn discharge chute clockwise to reversal position.
4. Locate it with two locking shafts and pins.

Checklist before Operation

CAUTION

Hazard control and accident prevention are dependent upon the awareness, concern, prudence, and proper training involved in the operation, transport, storage, and maintenance of the chipper. Therefore, it is absolutely essential that no one operates the machine without first having read, fully understood, and become totally familiar with the Operator's Manual. Make sure all operators have completed the Checklist below.

Before operating the machine, the following steps should be inspected carefully:

1. Before starting up the machine, check and lubricate all grease points, on the machine and drive shaft. Check the oil level in the gearbox if the implement has. Add as required.
2. Use only an agricultural tractor with horsepower within limits of the implement.

3. Check that the machine is properly attached to the tractor. Be sure retainers are used on the mounting pins.
4. Be sure extra weights are mounted on the front of the tractor, if required.
5. Check that the tractor PTO shaft turns freely and that the machine driving shaft can telescope easily.
6. Check the blades. Be sure they are not damaged or broken and swing freely in their mount. Repair or replace as required.
7. Check and tighten the blade bolts.
8. Check for entangled material in all rotating parts. Remove this material.
9. Install and secure all guards, hook and covers before starting.
10. Before installing the PTO ensure the engine is stopped and the PTO shaft is in safe working order.
11. All other people shall leave the area before connecting the driving power from the tractor.
12. Before cleaning, repairing and lubricating the machine, stop the motor and take the key away with you.
13. When the PTO shaft is not connected with the tractor, support it through the frame to protect it from lying in the dirt.
14. Don't approach the machine when it is operating.
15. Open the disc housing as described in [Opening and Closing Disc Housing](#).
16. Ensure that the wood chipper is free of any foreign bodies by turning the disc a few times by hand. Remove any foreign bodies.
17. Ensure that the knives run clear of the counter-knife.
18. Ensure that the distance between the knives and counter-knife is correct. Close the disc housing as described in [Opening and Closing Disc Housing](#).
19. Ensure that all of the bolts, nuts and screws are tightened securely.
20. Lubricate all of the lubrication points.
21. Grease nipples on bearings and PTO shaft.

Operating the Machine

WARNING

- Please remember it is important that you read the operator's manual and heed the safety signs on the 3-Point Hitch Wood Chipper. They are there for your safety, as well as the safety of others. The safe use of this machine is strictly up to you, the operator.
- Personal protection equipment including hearing protection, hard hat, safety glasses, safety shoes, and gloves are recommended during assembly, installation, operation, adjustment, maintaining, repairing, or plugging. Do not allow long hair, loose-fitting clothing, or jewelry to be around moving parts.
- Turn machine off, stop and disable engine, remove ignition key and place in your pocket, set park brake and wait for all moving parts to stop before servicing, adjusting, repairing or unplugging.
- Do not run machine inside a closed building to prevent asphyxiation from engine exhaust.
- Use care when feeding material into chip-per. Do not send metal, bottles, cans, rocks, glass or other foreign material into wood chipper. If foreign material enters chipper, stop machine, turn engine off and place ignition key in your pocket and wait for all moving parts to stop before removing material and/or unplugging. Inspect machine for damaged or loose parts before resuming work.
- Never use alcoholic beverages or drugs which can hinder alertness or coordination while operating this equipment. Consult your doctor about operating this machine while taking prescription medications.
- Do not allow riders on this machine at any time. There is no safe place for any riders.
- Never allow children or unauthorized people to operate or be around this machine.
- Do not reach into rotor or feed hopper openings when the engine is running. Install and secure access covers before starting engine.
- Do not move or transport chipper when the rotor is turning.
- Do not exceed a safe travel speed when transporting.
- Keep hydraulic system (if the implement has) and fittings tight, in good condition and free of leaks.
- Keep the working area clean and free of debris to prevent tripping. Operate only on level ground.
- Do not point discharge at people, animals or buildings. Rotor can expel wood chips fast enough to cause injury.

The wood chipper must stand on a secure and level surface during use and must be attached to the tractor's 3-point hitch. When using this machine, follow procedures below:

1. Clear the area of bystanders, especially small children.
2. Review and follow the **Checklist before Operation**.
3. Attach the machine to the tractor (see **Tractor Hook-up**).
4. Drive to the work area and position at the worksite.
5. Set park brake.
6. Stop engine.
7. Remove ignition key and place in your pocket.
8. Move the feed hopper down into its working configuration and secure with the anchor nuts.
9. Turn deflector of discharge chute to its working position.

Starting the Machine

- a) Start the tractor engine.
- b) Move the throttle to its low idle position.
- c) With the engine at low idle, slowly engage the PTO control.
- d) Slowly increase the engine speed until the PTO is at rated speed.
- e) With the manual feeding model, start feeding material into the hopper.

Feeding Materials

1. Slowly slide the wooden material into the feed hopper and move it into the rotor.
 - Do not push the material with a lot of force into the rotor.
 - Do not push the material too fast into the rotor. Stop and slow down the tractor if the engine starts to slow down.
 - Do not reach into the feed hopper further than the curtain to be sure not to contact the blades on the rotor.
2. Use a stick or branch to push any piece of material into the rotor. Do not take a chance with getting your hand caught in the rotor.

Stopping the Machine

1. Stop feeding material into the hopper.
2. Slow engine RPM.
3. Disengage PTO.
4. Stop engine, remove ignition key and place in your pocket and wait for all moving parts to stop.

SERVICE AND MAINTENANCE

General Service

The wood chipper must be inspected every day. This includes opening the disc housing and checking the feed, disc, blades, counter-knife. This will ensure that unexpected stoppages are avoided and prolong the life of the wood chipper.

For all service works, the wood chipper and the driving power must be completely stopped before any work may be carried out. Tractor-mounted wood chippers must be placed on an even surface and be disconnected from the tractor's PTO.

Maintenance Schedule

Listed schedule is common chipper that may or may not be applicable to your wood chipper.
If you have any problem not covered in the list, please contact us freely.

◆ indicates for each stated time interval

● indicates only for the first time

Interval=> hours	8h	50h	200h	1000h
Lubricate the PTO shaft	◆			
Check the knives and counter-knife	◆			
Tighten all bolts and nuts	●	◆		
Lubricate disc main bearings		◆		
Clean/lubricate tube connection for PTO shaft		◆		
Reverse/replace counter-knife			◆	
Check deflector for wear and tear				◆
Check housing for wear and tear				◆

PTO Shaft Maintenance

It is recommended to lubricate the PTO shaft with multi-purpose grease after every 8 to 10 hours of use during heavy use. The PTO shaft is designed to telescope to allow for dimensional changes as the machine goes through its operating range. A tubular guard encloses the driving components and is designed to turn relative to the driving components. The shaft should telescope easily and the guard turn freely on the shaft at all times. Annual or 1000h disassembly, cleaning and lubrication is recommended to insure that all components function as intended. To maintain the shaft, follow this procedure:

1. Remove the shaft from the machine.
2. Pull shaft apart.
3. Use a screwdriver to pry the tabs out of the sleeves on each end.
4. Pull the shaft out of the plastic tubular guard.
5. Use a solvent to clean the male and female portions of the telescoping ends.
6. Apply a light coat of grease to each end.
7. Clean the grooves on each end where the tabs are located. Clean each tab also.
8. Apply a light coat of grease to each groove.
9. Insert the shaft into its respective guard and align the slots with the groove.
10. Insert the tabs through the slots and seat in the groove.
11. Check that each guard turns freely on the shaft.
12. Assemble the shaft.
13. Check that the shaft telescopes easily.
14. Replace any components that are damaged or worn.
15. Install the shaft on the machine.

Tightening Torque

Please follow the table below to identify the torque value as required.

Torque Values Chart for Common Bolt Sizes													
Bolt Size (inches)	Bolt Head Identification						Bolt Size (Metric)	Bolt Head Identification					
	Grade 2		Grade 5		Grade 8			Class 5.8		Class 8.8		Class 10.9	
in-tpi ¹	N · m ²	ft-lb ³	N · m	ft-lb	N · m	ft-lb	mm x pitch ⁴	N · m	ft-lb	N · m	ft-lb	N · m	ft-lb
1/4" - 20	7.4	5.6	11	8	16	12	M 5 X 0.8	4	3	6	5	9	7
1/4" - 28	8.5	6	13	10	18	14	M 6 X 1	7	5	11	8	15	11
5/16" - 18	15	11	24	17	33	25	M 8 X 1.25	17	12	26	19	36	27
5/16" - 24	17	13	26	19	37	27	M 8 X 1	18	13	28	21	39	29
3/8" - 16	27	20	42	31	59	44	M10 X 1.5	33	24	52	39	72	53
3/8" - 24	31	22	47	35	67	49	M10 X 0.75	39	29	61	45	85	62
7/16" - 14	43	32	67	49	95	70	M12 X 1.75	58	42	91	67	125	93
7/16" - 20	49	36	75	55	105	78	M12 X 1.5	60	44	95	70	130	97
1/2" - 13	66	49	105	76	145	105	M12 X 1	90	66	105	77	145	105
1/2" - 20	75	55	115	85	165	120	M14 X 2	92	68	145	105	200	150
9/16" - 12	95	70	150	110	210	155	M14 X 1.5	99	73	155	115	215	160
9/16" - 18	105	79	165	120	235	170	M16 X 2	145	105	225	165	315	230
5/8" - 11	130	97	205	150	285	210	M16 X 1.5	155	115	240	180	335	245
5/8" - 18	150	110	230	170	325	240	M18 X 2.5	195	145	310	230	405	300
3/4" - 10	235	170	360	265	510	375	M18 X 1.5	220	165	350	260	485	355
3/4" - 16	260	190	405	295	570	420	M20 X 2.5	280	205	440	325	610	450
7/8" - 9	225	165	585	430	820	605	M20 X 1.5	310	230	650	480	900	665
7/8" - 14	250	185	640	475	905	670	M24 X 3	480	355	760	560	1050	780
1" - 8	340	250	875	645	1230	910	M24 X 2	525	390	830	610	1150	845
1" - 12	370	275	955	705	1350	995	M30 X 3.5	960	705	1510	1120	2100	1550
1-1/8" - 7	480	355	1080	795	1750	1290	M30 X 2	1060	785	1680	1240	2320	1710
1-1/8" - 12	540	395	1210	890	1960	1440	M36 X 3.5	1730	1270	2650	1950	3660	2700
1-1/4" - 7	680	500	1520	1120	2460	1820	M36 X 2	1880	1380	2960	2190	4100	3220
1-1/4" - 12	750	555	1680	1240	2730	2010							
1-3/8" - 6	890	655	1990	1470	3230	2380							
1-3/8" - 12	1010	745	2270	1670	3680	2710							
1-1/2" - 6	1180	870	2640	1950	4290	3160							
1-1/2" - 12	1330	980	2970	2190	4820	3560							

¹ in-tpi = nominal thread diameter in inches-threads per inch
² N · m = newton-meters
³ ft-lb = foot pounds
⁴ mm x pitch = nominal thread diameter in millimeters x thread pitch

Torque tolerance + 0%, -15% of torquing values. Unless otherwise specified use torque values listed above.
 All locknuts or lubricated fasteners: Use 75% of torque value. (i.e. 1/2"-13 GR5 = 76 ft-lb; 75% of 76 or .75 x 76 = 57 ft-lb)

- This chart is an approximate estimate of torque values.
- Always tighten hardware to these values unless a different torque value or tightening procedure is listed for a specific application.
- Fasteners must always be replaced with the same grades as specified in the manual.
- Always use the proper tool for tightening hardware; SAE for SAE hardware and Metric for Metric hardware.
- Make sure that fastener threads are clean and that you properly start thread engagement.

Replacing Blades

The knives must always be changed as a set. The knives belong together in sets, also when they are ground so that they are always of equal width. If the knives are not of equal width, the disc will be out of balance, which will lead to unnecessary strain on the bearings and vibrations in the whole wood chipper.

IMPORTANT:

- Frequently check rotor blades and counter-knife they are in good working condition and properly secured. Replace worn or damaged parts with new blades. Make sure that the replacement of blade in the same weight to guarantee a balance of rotor spinning.
- Recommend blade is the original factory accessories.

To replace a new blade:

1. Open the disc housing, refer to [Opening and Closing Disc Housing](#).
2. Remove the nut (1), flat washer (2) and bolts (3) that hold the knives securely to the disc.
3. Remove the knives (4).
4. Carefully clean the knives (1), disc faces.
5. Check that the distance between the knife edge and the counter-knife. Check all of the knives.
6. Tighten the bolts.
7. Finally, close the disc housing, refer to [Opening and Closing Disc Housing](#).

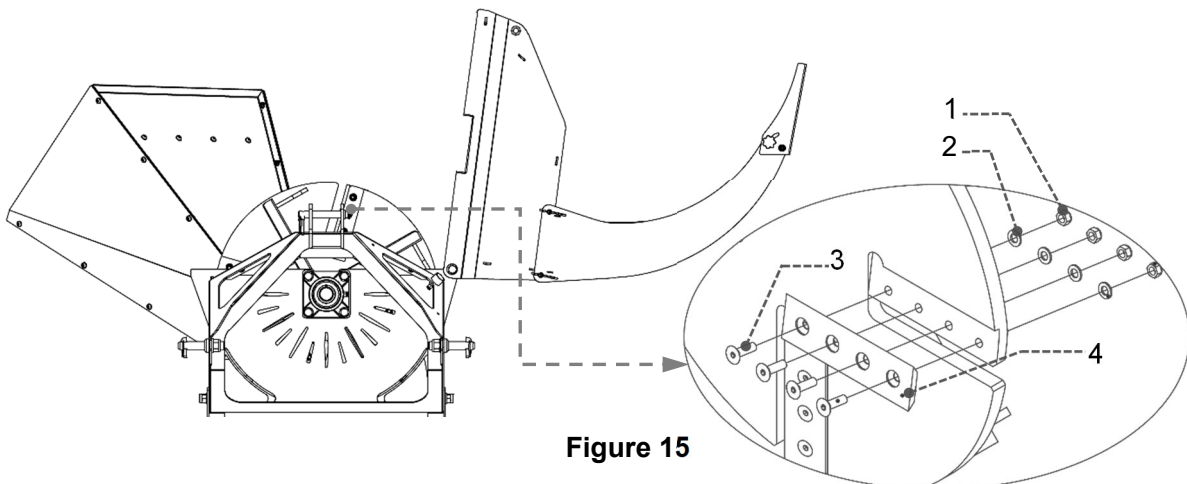

Figure 15

Note: If you have any problem during operation, please contact us for supporting.

STORAGE AND TRANSPORT

Storage

Before storage the implement, you should following the steps below:

1. Remove any dirt and grease that may have accumulated on the chipper and moving parts. Scrape off compacted dirt from under the hood. Clean the machine inside and out so as to avoid corrosion.
2. Check rotor, blades, blade mounts, and blade bolts for wear and replace if necessary.
3. Don't spray water on the rolling bearing if you clean the machine with high pressure sprayer.
4. Check and clean the universal joint and driving belt press roller if the chipper has, or replace them if they are not in good condition. Lubricate wherever needed.
5. Recoat the parts rubbed and damaged for anti-corrosion.
6. Store the machine in a dry, level area.

Transport

WARNING

- Always disengage power take-off before raising chipper to transport position.
- When traveling on roadways, travel in such a way that other vehicles may pass you safely. Always use LED lights, clean reflectors, and a slow moving vehicle sign that is visible from the back to warn operators in other vehicles of your presence.
- Always comply with all federal, state, and local laws.

Before transport the implement, you should following the steps below:

1. When raising chipper to transport position, be sure driveline does not contact tractor or implement. If needed, adjust and set tractor 3-point lift height to limit implement movement and to protect driveline.
2. The tipping bucket must be folded and the discharge chute should be faced to disc housing.
3. Be sure to reduce tractor ground speed when turning, leaving enough clearance so that the implement does not contact obstacles such as buildings, trees, fences, etc.
4. Select a safe ground travel speed when transporting from one area to another. When traveling on roadways, transport in such a way that faster moving vehicles may pass safely.
5. When traveling over rough or hilly terrain, shift tractor to a lower gear.

TROUBLESHOOTING

Listed general troubleshooting is the common malfunction that may or may not be application to the described in this manual. If you have any problem not covered in the list, please contact us for technical supporting.

General troubleshooting list:

Malfunction	Possible Cause	Solution
Disc does not turn.	Obstructed discharge chute.	Clear debris from discharge chute.
	Disc plugged.	Inspect and clear chipper hopper, lower disc housing, and disc.
Slow feeding.	Roller rotation speed low.	Adjust speed.
	Rotor blades or counter-knife is dull.	Replace blades or counter-knife.
	Rotor blade angle wrong, improper angle.	Re-sharpen knives to specified angle and check that blade is installed properly.
	Obstructed discharge.	Clear debris from discharge chute.
Unusual vibration while working.	Broken or missing blade.	Replace a new blade.
	Disc may be blocked.	Invert first and spit out the broken wood.
Machine requires excessive power or stalls.	Obstructed discharge.	Clear debris from discharge chute.
	Feeding in too much material.	Feed smaller amounts into chipper hopper
	Feeding material too quickly	Feed larger material slowly into chipper hopper.
	Rotor plugged.	Inspect and clear chipper hopper lower disc housing and rotor.
	Green material does not discharge.	Allow material to dry or alternate dry/wet material.
	Chipper blade clearance too large.	Set clearance between knife and counter-knife.
	Dull blades.	Replace a new blade.

EXPLODED VIEW AND PARTS LIST

MACHINE ASSEMBLY

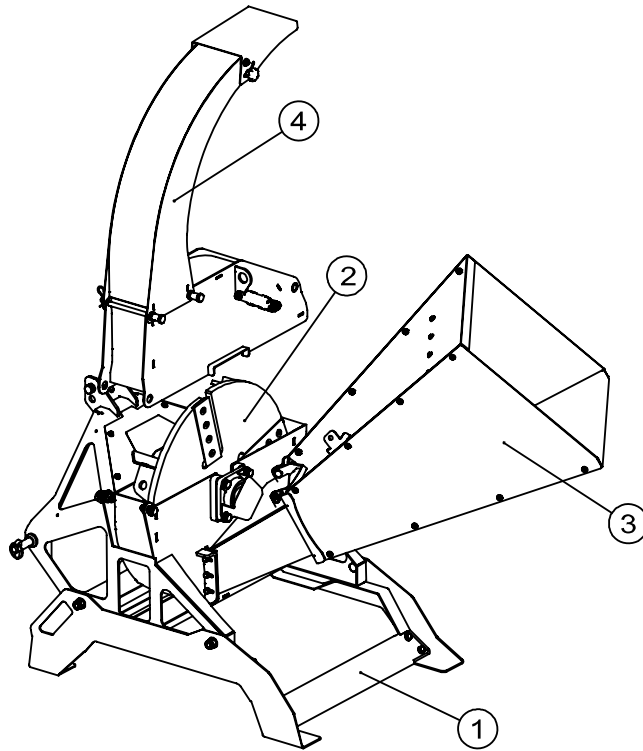

Machine assembly description list:

POS.	COD.	Specification	Description	QTY.
1	2060108217	W01020A01000-000	Host assembly	1
2	2060108218	W01020A02000-000	Knife disc assembly	1
3	2060108220	W01020A03000-000	Feed hopper	1
4	2060108219	W01020A06000-000	Discharge chute	1

HOST ASSEMBLY

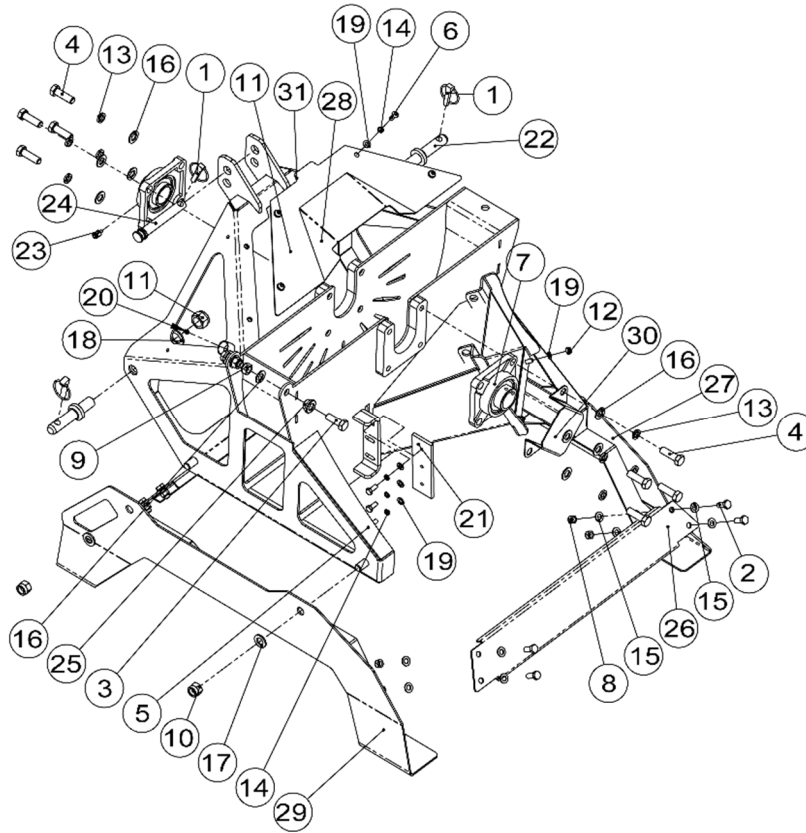

Host assembly description list:

POS.	COD.	Specification	Description	QTY.
1	3120400007	GB/T4329-12-EP•Zn	Pin	3
2	3040100043	GB/T5783-M10×25-8.8-EP•Zn	Full-thread hex. bolts	8
3	3040100092	GB/T5783-M14×40-8.8-EP•Zn	Full-thread hex. bolts	2
4	3040100094	GB/T5783-M14×45-8.8-EP•Zn	Full-thread hex. bolts	8
5	3040200001	GB/T5786-M8×1×20-8.8-EP•Zn	Full-thread hex. bolts (fine pitch)	3
6	3060300004	GB/T70.2-M8×20-8.8-EP•Zn	Hex. socket button head screws	4
7	3100700020	GB/T7810-UCF208	Outer spherical ball bearing with seat	2
8	3050500004	GB/T889.1-M10-8-EP•Zn	Locknut	8
9	3050500008	GB/T889.1-M14-8-EP•Zn	Locknut	2
10	3050500009	GB/T889.1-M16-8-EP•Zn	Locknut	4
11	3050500012	GB/T889.1-M22-8-EP•Zn	Locknut	2

POS.	COD.	Specification	Description	QTY.
12	3050500003	GB/T889.1-M8-8-EP•Zn	Locknut	2
13	3080500010	GB/T93-14-EP•Zn	Spring washer	8
14	3080500007	GB/T93-8-EP•Zn	Spring washer	7
15	3080100006	GB/T95-10-EP•Zn	Plain washer	16
16	3080100008	GB/T95-14-EP•Zn	Plain washer	10
17	3080100009	GB/T95-16-EP•Zn	Plain washer	4
18	3080100012	GB/T95-22-EP•Zn	Plain washer	2
19	3080100004	GB/T95-8-EP•Zn	Plain washer	9
20	3170400031	JB/T7940.1-M6-	Cup	1
21	3220100018	MT20003	Blade	1
22	3120500011	MT95011	Pin	2
23	3260300607	PC6-M6	Air joint	2
24	2010005308	R02024A03000-002	Hanging on the pin	1
25	2010005738	W01017A01000-002	Spacer sleeve	2
26	2000006966	W01019A01000-005	Plate	2
27	2020008247	W01019A01200-000	Left foot	1
28	2020008069	W01019A01300-000	Hood plate	1
29	2020008248	W01019A01400-000	Right foot	1
30	2000006807	W01020A01000-002	Cover plate	1
31	2020008285	W01020A01100-000	Main frame weldment	1

KNIFE DISC ASSEMBLY

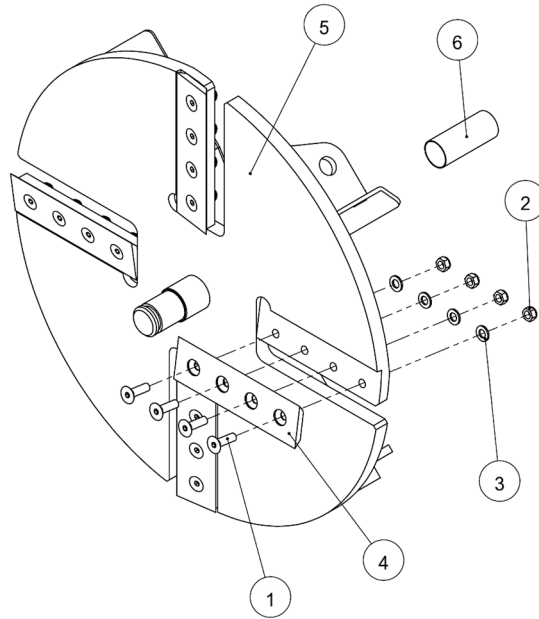

Knife disc assembly description list:

POS.	COD.	Specification	Description	QTY.
1	3060200035	GB/T70.3-M10×35-8.8-EP•Zn	HSCS-Countersunk	16
2	3050500004	GB/T889.1-M10-8-EP•Zn	Locknut	16
3	3080100006	GB/T95-10-EP•Zn	Plain washer	16
4	3220100007	MT21001	Blade	4
5	2020008286	W01020A02100-000	Rotor	1
6	3210500603	Φ35×90	Rubber	1

FEED HOPPER

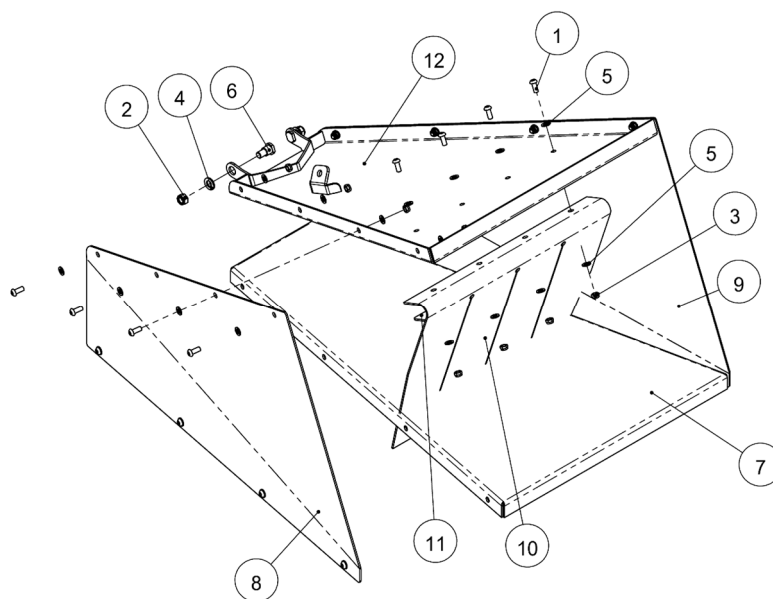

Feed hopper description list:

POS.	COD.	Specification	Description	QTY.
1	3060300004	GB/T70.2-M8×20-8.8-EP•Zn	Hexagon socket button head screws	20
2	3050500007	GB/T889.1-M12-8-EP•Zn	Locknut	2
3	3050500003	GB/T889.1-M8-8-EP•Zn	Locknut	20
4	3080100007	GB/T95-12-EP•Zn	Plain washer	2
5	3080100004	GB/T95-8-EP•Zn	Plain washer	40
6	2010006320	W01019A03000-002	Pin	2
7	2000006813	W01020A03000-001	Bottom plate	1
8	2000006812	W01020A03000-002	Left plate	1
9	2000006811	W01020A03000-003	Right plate	1
10	3210300645	W01020A03000-006	Flap Hopper	1
11	2000006814	W01020A03000-007	Strap Hopper Flap	1
12	2020008290	W01020A03100-000	Top plate component	1

DISCHARGE CHUTE

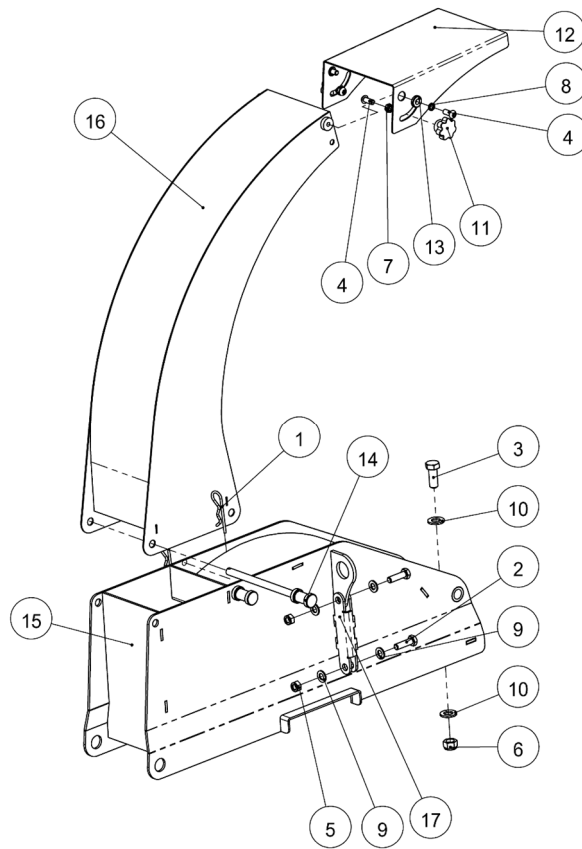

Discharge chute parts description list:

POS.	COD.	Specification	Description	QTY.
1	3120400008	Din11024-4-EP•Zn	R Pin	2
2	3040100046	GB/T5783-M10×35-8.8-EP•Zn	Full-thread hexagon bolts	2
3	3040100091	GB/T5783-M14×35-8.8-EP•Zn	Full-thread hexagon bolts	1
4	3060300004	GB/T70.2-M8×20-8.8-EP•Zn	Hexagon socket button head screws	4
5	3050500004	GB/T889.1-M10-8-EP•Zn	Locknut	2
6	3050500008	GB/T889.1-M14-8-EP•Zn	Locknut	1
7	3050500003	GB/T889.1-M8-8-EP•Zn	Locknut	2
8	3080500007	GB/T93-8-EP•Zn	Spring washer	2
9	3080100006	GB/T95-10-EP•Zn	Plain washer	4
10	3080100008	GB/T95-14-EP•Zn	Plain washer	2
11	3210500016	M8	Rubber	2

POS.	COD.	Specification	Description	QTY.
12	2000006810	W01020A06000-001	Deflector plate	1
13	2010006327	W01020A06000-002	Spacer sleeve	2
14	2010006328	W01020A06000-004	Pin	2
15	2020008287	W01020A06100-000	Flap	1
16	2020008288	W01020A06200-000	Discharge port	1
17	2020008289	W01020A06300-000	Connecting rod	1

WARRANTY

The Manufacturer warrants to the original purchaser that this product will be free from defects in material and workmanship beginning on the date of purchase by the end user according to the following schedule when used as intended and under normal service and conditions for personal use.

Overall Unit and Driveline: 24 months Parts and Labor

Blades: Consumables materials

This Warranty is limited to the replacement of any defective part by the Manufacturer and the installation by the dealer of any such replacement part, and does not cover common wear items. The Manufacturer reserves the right to inspect any equipment or parts which are claimed to have been defective in material or workmanship.

This Warranty does not apply to any part or product which in Manufacturer's judgment shall have been misused or damaged by accident or lack of normal maintenance or care, or which has been repaired or altered in a way which adversely affects its performance or reliability, or which has been used for a purpose for which the product is not designed. Misuse also specifically includes failure to properly maintain oil levels, grease points, and driveline shafts.

Claims under this Warranty should be made to the dealer which originally sold the product and all warranty adjustments must be made through an authorized Manufacturer dealer. The Manufacturer reserves the right to make changes in materials or design of the product at any time without notice.

This Warranty shall not be interpreted to render Manufacturer liable for damages of any kind, direct, consequential, or contingent to property. Furthermore, the Manufacturer shall not be liable for damages resulting from any cause beyond its reasonable control. This Warranty does not extend to loss of crops, any expense or loss for labor, supplies, rental machinery or for any other reason.

No other warranty of any kind whatsoever, express or implied, is made with respect to this sale; and all implied warranties of merchantability and fitness for a particular purpose which exceed the obligations set forth in this written warranty are hereby disclaimed and excluded from this sale.

This page left blank intentionally!

